

Viega GmbH & Co. KG  
Plumbing and heating systems  
Viega Platz 1  
DE-57439 Attendorn  
Germany  
Phone +49 2722 61-1297  
Fax +49 2722 61-1146  
info@viega.com  
www.viega.com



Application technology: Vol. I 3rd edition

## Application technology

Vol. I: Metallic pipe installation systems  
3rd edition





**Application technology**

Metallic pipe installation systems

Sanpress, Sanpress Inox, Sanpress Inox G, Profipress, Profipress G, Prestabo, Megapress  
INT 670 818 03/14

**Published by**

Viega GmbH & Co. KG

Plumbing and heating systems

Viega Platz 1

DE-57439 Attendorn

Germany

Phone +492722 61-0

Fax +492722 61-1415

[www.viega.com](http://www.viega.com)

The contents of this handbook is not binding. We reserve the right to make changes which serve the purpose of new inventions and advancements.

# **Metallic pipe installation systems**

Safety and comfort in a system range

- 1 Drinking water installation**
- 2 Heating technology**
- 3 Gas installation**
- 4 Industrial and commercial uses**
- 5 Tool systems**





### **Instruction of use**

The technical information in this handbook describes the fundamental points of the Viega application technology for metallic pipe installation systems. In addition, the information about the products, their properties and the application techniques is based on the current standards in Europe and/or in Germany.

Sections of the text which are marked with an asterisk (\*) correspond to the technical regulations in Europe/ Germany. These should be understood as recommendations if appropriate national requirements do not exist. The relevant national laws, standards, regulations, norms and other technical regulations have precedence over the German/European guidelines in this handbook: The information given here is not binding for other countries and territories and, as mentioned, should be considered as support.

# 1 Drinking water installations

## Basic principles

<b>Saving Potential</b> . . . . .	<b>15</b>
<b>Planning</b> . . . . .	<b>16</b>
<b>Regulation of water for human consumption</b> . . . . .	<b>16</b>
<b>Pipe material</b> . . . . .	<b>16</b>
Lead pipes . . . . .	16
Materials without restrictions . . . . .	17
Hot-dip galvanised ferrous materials . . . . .	17
<b>Combination of different materials*</b> . . . . .	<b>17</b>
<b>Prevention/reduction of the build up of limescale</b> . . . . .	<b>18</b>
<b>Viega Pipe system philosophy</b> . . . . .	<b>18</b>
Service connection and earth-laid pipes made of PE . . . . .	18
Cellar manifold and riser pipes made of metal . . . . .	19
Storey distribution for PE-Xc pipes . . . . .	19
<b>Pipe routing and water exchange</b> . . . . .	<b>20</b>
<b>Fire extinguishing and fire prevention units</b> . . . . .	<b>21</b>
<b>Pipe network calculation</b> . . . . .	<b>21</b>
<b>Visign for Care – Hygiene flush function</b> . . . . .	<b>22</b>
<b>Installation</b> . . . . .	<b>24</b>
Storage and assembly . . . . .	24
Wet leakage test . . . . .	25
Dry leakage test . . . . .	25
Procedure . . . . .	26
Commissioning . . . . .	26
Disinfection . . . . .	27
<b>Cost effectiveness of pipe systems</b> . . . . .	<b>28</b>
<b>Overview of metallic pipe systems</b> . . . . .	<b>30</b>

## System descriptions

<b>Sanpress Inox/Sanpress Inox XL</b> . . . . .	<b>31</b>
Intended use . . . . .	31
Technical data . . . . .	32
<b>Sanpress/Sanpress XL</b> . . . . .	<b>33</b>
Intended use . . . . .	33
Technical data . . . . .	34
<b>Profipress/Profipress XL</b> . . . . .	<b>35</b>
Intended use . . . . .	35
Technical data . . . . .	36



## Application technology

<b>Insulation*</b>	<b>37</b>
Cold water pipes	37
Drinking water piping systems (PWH)*	38
<b>Noise protection</b>	<b>38</b>
<b>Fire protection*</b>	<b>39</b>
<b>Elongation – compensating members</b>	<b>40</b>
<b>U- or Z-expansion compensating members</b>	<b>40</b>
Calculating length of expansion bends for pipes $\varnothing < 54$ mm	42
Calculating length of expansion bends of pipes $\varnothing > 54$ mm	44
<b>Axial compensator</b>	<b>46</b>
<b>Fixed Points / Gliding Points Function</b>	<b>47</b>
<b>Loss of pressure in pipes</b>	<b>48</b>
<b>Corrosion of stainless steel pipes caused by chloride</b>	<b>49</b>



## Components

<b>Easytop-slanted seated valves</b>	<b>50</b>
Technical data – Versions.	52
Accessories	52
Easytop XL-slanted seated valves with flange connection	56
Pressure loss diagram Easytop fittings	58
<b>Easytop sampling valves</b>	<b>59</b>
Project description	59
Easytop sampling valve, two-piece.	60
Easytop sampling valve, one-piece.	62
<b>Easytop-concealed straight seated valve.</b>	<b>64</b>
Technical data	64
Connection variations	64
Valve construction	64
<b>Easytop-concealed free-flow valves</b>	<b>65</b>
Technical data	65
Fastening/Seal.	67
Mounting by placing it through a wall	67
Mounting using the assembly set	67
Fitting sets	68
Insulating sleeve	68
<b>Easytop-ball valves</b>	<b>69</b>
<b>Thermostatic circulation regulating valve S / E</b>	<b>70</b>
Product description	70
Thermal disinfection.	71
Assembly	71
Electrical installation	75
Technical data	75







<b>Static circulation regulating valve</b>	<b>76</b>
Product description	76
Pressure loss diagrams	77
<b>Smartloop-Inliner circulation line</b>	<b>78</b>
System Description	78
Components	82
Assembly	83
Repair coupling	86
<b>Sealing elements – overview</b>	<b>87</b>
<b>Mixed installations</b>	<b>88</b>
<b>Insulated pipe joint</b>	<b>88</b>
<b>Boiler connection</b>	<b>89</b>
<b>Potential equalisation</b>	<b>89</b>

## Assembly



<b>Storage and transportation</b>	<b>90</b>
<b>Pipes</b>	<b>90</b>
Cutting	90
Bending	91
Routing and fastening	91
Concealed installation of pipes that become hot	92
<b>Threaded joints</b>	<b>92</b>
<b>Flanged connections</b>	<b>92</b>
<b>Making the press connection</b>	<b>93</b>
Pipe sizes 12 – 54 mm	93
Sanpress XL – pipe sizes 76.1 – 108.0 mm	95
Sanpress Inox XL/Profipress XL – pipe sizes 64.0 – 108.0 mm	97
<b>Space requirement for pressing</b>	<b>99</b>
Pipe sizes 12–54 mm	99
Pipe sizes 76.1–108.0 mm Sanpress XL with ring	101
Press tool for Sanpress Inox XL/Profipress 64.0 mm	102
<b>Basic rules for commissioning</b>	<b>103</b>
SC-Contur	103
Disinfection	103

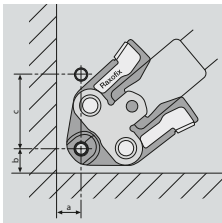

## Appendix

<b>Loss of pressure – tables</b>	<b>105</b>
Cold water in stainless steel pipes	105
Warm water in stainless steel pipes	107
<b>Reports</b>	<b>109</b>
Report – Flushing with water	109
Report – Pressure test for drinking water supply systems	110
Report – Pressure test for drinking water supply systems	111
<b>Combination of pipe materials in drinking water installations</b>	<b>112</b>

# 2 Heating technology

## Copper piping systems

<b>Profipress – System description</b>	<b>113</b>
<b>Intended use</b>	<b>113</b>
<b>Technical data</b>	<b>114</b>
<b>Components</b>	<b>115</b>
Pipes	115
Press connectors	115
Easytop-ball valves	117
Sealing elements	118
<b>Application technology</b>	<b>119</b>
<b>Riser pipes</b>	<b>119</b>
<b>Back flow connection</b>	<b>120</b>
<b>Radiator connections</b>	<b>121</b>
With Central Floor manifold	121
With Crossover-tee	123
With Tee-installation	125
With Baseboard radiator connection	127
Adapter sets for valve radiators	128
<b>Insulation and laying of pipe systems*</b>	<b>129</b>
Insulation against heat loss*	129
Heat distributing systems	130
Pipes in floors	131
Examples	131
<b>Mixed installations</b>	<b>133</b>
<b>Leakage test</b>	<b>133</b>
With water	133
With air	133
<b>District heating systems</b>	<b>134</b>
<b>Profipress S – System description</b>	<b>135</b>
<b>Intended use</b>	<b>135</b>
<b>Application technology</b>	<b>136</b>
Piping system	136
Flushing	136
Pressure test	136

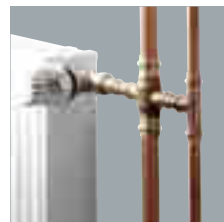

&gt;&gt;

## Steel piping systems



<b>Prestabo – System description</b>	<b>138</b>
<b>Intended use</b>	<b>138</b>
<b>Technical data</b>	<b>139</b>
<b>Components</b>	<b>140</b>
Pipes	140
Pipe markings	141
Press connectors	142
Sealing elements	143
<b>Application technology</b>	<b>144</b>
<b>Protection from external corrosion</b>	<b>144</b>
<b>Cooling water circuits</b>	<b>145</b>
<b>Protection from internal corrosion (three-phase limit)</b>	<b>145</b>
<b>Insulation and installation*</b>	<b>145</b>
<b>Potential equalisation*</b>	<b>148</b>
<b>Mixed installations</b>	<b>148</b>
<b>Pipe fitting and fastening</b>	<b>149</b>
<b>Elongation – compensating members</b>	<b>149</b>
Elongation Prestabo-piping systems	150
U- or Z-expansion compensating members – calculation	151
<b>Assembly</b>	<b>155</b>
<b>Storage and transportation</b>	<b>155</b>
<b>Preparation</b>	<b>155</b>
Shortening	155
Dismantling	155
De-burring	156
Bending	156
<b>Assembly examples</b>	<b>157</b>
<b>Fastening methods – fixed and gliding points</b>	<b>158</b>
<b>Concealed installation</b>	<b>159</b>
<b>Laying in screed</b>	<b>159</b>
<b>Laying in tar screed – mastic asphalt</b>	<b>160</b>
<b>Space requirement for pressing</b>	<b>161</b>
Pipe sizes 12–54 mm	161
Pipe sizes 64,0 – 108,0 – Prestabo XL	163
Pressing with pressrings 12 – 54 mm	164
<b>Making the press connection</b>	<b>165</b>
Pipe sizes 12 – 54 mm	165
Pipe sizes 64.0 – 108.0 mm	168
<b>Leakage test</b>	<b>170</b>

# 3 Gas installation\*

## Basic principles

Use of natural gas . . . . .	171
Viega system philosophy . . . . .	172
Requirements for gas sockets . . . . .	173

## System descriptions

<b>Profipress G/Profipress G XL . . . . .</b>	<b>174</b>
Intended use . . . . .	174
Technical data . . . . .	175
Markings of the press connectors . . . . .	176
HTB-requirements . . . . .	176
Gas systems . . . . .	177
<b>Sanpress Inox G/Sanpress Inox G XL . . . . .</b>	<b>178</b>
Intended use . . . . .	178
Technical data . . . . .	179
Markings of the Press connectors . . . . .	180
Press connectors with SC-Contur . . . . .	180
<b>Assembly . . . . .</b>	<b>181</b>
General rules of assembly for gas piping systems . . . . .	181
Requirements for concealed installations . . . . .	181
Pipe installation and fastening . . . . .	182
Laying in floors . . . . .	183
Corrosion protection . . . . .	183



&gt;&gt;

## 4 Industrial / commercial uses

### System descriptions



Megapress . . . . .	184
Assembly . . . . .	187
Profipress/Sanpress Inox/Profipress G / Sanpress Inox	
G/Prestabo . . . . .	195
Intended use . . . . .	195
Profipress / Profipress G . . . . .	196
Sanpress Inox/Sanpress Inox XL . . . . .	198
Prestabo . . . . .	200

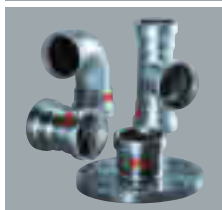

### Application technology

SC-Contur – DVGW-tested safety . . . . .	201
Flanged connections . . . . .	203

### Areas of use

Compressed air systems . . . . .	203
Cooling water systems. . . . .	205
Process water system . . . . .	206
Systems for technical gases . . . . .	207
Low pressure steam systems . . . . .	209
Application in shipbuilding . . . . .	209
Sanpress Inox/Prestabo Labs-free . . . . .	210
Easytop ball valves . . . . .	211



## 5 Tool systems

### System descriptions

Intended use . . . . .	213
Press machines . . . . .	214
Pressgun 5 with mains adapter . . . . .	214
Pressgun 5 with battery . . . . .	215
Pressgun Picco – Battery . . . . .	216
Compatibility with Pressgun 4 battery and battery charger . . . . .	217
<b>Compatibility with products from other manufacturers</b> . . . . .	217
Pressing tools . . . . .	218
Jointed press rings . . . . .	218
For Viega pipe systems made of metal . . . . .	218

For XL press connectors . . . . .	218
<b>Press chains / press jaws . . . . .</b>	<b>219</b>
<b>Compatibility . . . . .</b>	<b>220</b>
<b>Maintenance . . . . .</b>	<b>226</b>
<b>Care und cleaning . . . . .</b>	<b>226</b>
Press machines . . . . .	226
Press rings / press jaws . . . . .	227
<b>Tool Service . . . . .</b>	<b>227</b>

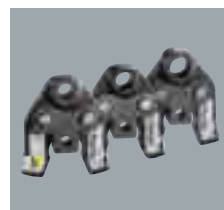

# 1 Drinking water installations

## Basic principles

Clean drinking water is a prerequisite for our health. It contains essential minerals and elements and is used for the preparation of food, for cleaning objects and for personal hygiene. The common goal of the planner, tradesperson and supplier is to provide drinking water to every tap in sufficient quantities and of an acceptable quality. Drinking water is a perishable foodstuff. Its constitution changes in the drinking water installation, e.g. through contact with materials, heat or periods of stagnation with the relevant build up of bacteria.

Drinking water is a foodstuff



Fig. D – 1

Level of infection  
(national comparison)

In Germany, the number of people who contract Legionnaire's disease is around 30,000 every year. With a fatality rate of 10 up to 15 % this represents roughly 3,000 deaths per year. The infection rate is much lower in other countries: 34.1 (Spain), 19.2 (Denmark), 17.9 (The Netherlands) and 16.9 (France) per million inhabitants.

To avoid problems, every country has regulations for the safe supply of water. New regulations, which compliment or replace national regulations, are constantly being introduced by the EU. A good example is the technical report "Recommendations for prevention of Legionella growth in installations inside buildings conveying water for human consumption". And with the EN 806 a great step was done to a common understanding of drinking water installations in Europe. Developments like this makes it necessary to consult the regulations for such technology on a regular basis and to use them in practice at short notice. For example, in Germany the dry leakage test has become standard in large installations such as hospitals or hotels due to reasons of hygiene. Even the flushing of the installation takes place as late as possible.

If one wanted to summarise all the measures for the protection of drinking water then it would be:

- » **Planning and Installation should lead to small dimensioning of piping.**«
- » **Every part of an installation should be used once a week after first filling or should be avoided.**«
- » **Also Avoid continual temperatures between 25 and 55°C during operation.**«

As has already been mentioned, the construction of drinking water installations requires a great deal of technical know-how. EN 806 and EN 1717 are examples of the attempts being made to create European standards for the installation and protection of drinking water. This chapter contains the most important measures for the preservation of drinking water. It allows the reader an overview of the relevant aspects for professional planning construction and operation of drinking water installations. This should be seen as a guideline as current national requirements should be observed. The Viega employees support the trade persons in their daily work.

## Saving Potential

Clean water is a vital commodity. Not everywhere has a sufficient amount. Therefore it is necessary to see how water conservation measures affect drinking water supplies. Hygienists in buildings for medical purposes demand that the water in the building is changed between two and three times a week.

Alongside water saving there are measures to reduce the amount of energy used. Low temperatures can lead to a risk of legionella, therefore an optimal balance between the protection of health and saving potential has to be found.



Fig. D – 2

Water conservation  
versus hygiene



<sup>1</sup> Council Directive 98/83/EC of 3 November 1998 on the quality of water intended for human consumption

## Planning

### Regulation of water for human consumption

In 1998<sup>1</sup> the European drinking water directive came into effect. This set down minimum standards for water for human use, for drinking, for cooking, for preparing food and for domestic use. The quality level has to be observed at all extraction points at which water is taken for this purpose. It is irrelevant if it is warm or cold water. When planning a drinking water installation the following topics should be discussed with the local water supplier.

#### Service connection

- Who is responsible for installation?
- Ownership?
- Material? Nominal width?
- House connection – where?

#### Water meter

- Who is responsible for installation?
- Size of meter?
- Backflow prevention?

#### Pressure

- Level of minimum supply pressure/where is it measured?
- Maximum standing pressure?

#### Drinking water constitution

- Possible material restrictions

### Pipe material

The materials and products must conform to the national requirements. Work on house installations may only be carried out by qualified professionals. According to, for example EN 12502, the quality of the drinking water should be considered in the planning phase. Every pipe material has its limitations, which may not be reached in normal circumstances but may be crossed in other cases. Therefore, when in doubt, it is advisable to consult the component manufacturer.

### Lead pipes

The publication of the Drinking Water Directive in 1998 saw the start of a 15 year transition period for replacing old systems made of lead pipes. For no later than 2013, the new European threshold value for lead was announced as 10 µg / l, which cannot be complied with either with calcified lead piping or the dosing of corrosion inhibitors. This generally means that the entire lead pipework network needs replacing.

**Check stock, use is not permitted!**

**DIN EN 806-2  
Point 5.1**

### Materials without restrictions

Without any water-side restrictions, the following piping materials and systems can be used in compliance with national certification marks

- Stainless steel Viega Sanpress / Sanpress Inox
- Internally galvanised copper
- Plastic pipes

Copper pipes and press connectors can generally be used in all types of drinking water. There may be some national regulations to which to adhere.

- If the pH value is  $\geq 7.4$  or
- If the pH value is between 7.0 and 7.4 and the TOC value does not exceed 1.5 mg/l.

Copper pipes must not be used with a pH value of  $< 7.0$ .

### Hot-dip galvanised ferrous materials

Should only be used for cold drinking water in accordance with EN 12502, as there is an increased risk of corrosion with temperatures exceeding 35 °C.

In addition, the following restrictions apply for this material:

- If the base capacity is KB 8.2 - 0.5 mol/m<sup>3</sup> and, at the same time,
- The acid capacity is KS 4.3 - 1.0 mol/m<sup>3</sup>.

The increased requirements of galvanisation must be fulfilled.

### Combination of different materials\*

The use of various materials in drinking water installations complies with the technical regulation. For example, copper pipes, internally tin coated copper pipes, stainless steel and PE-X can be combined.



Fig. D – 3

EN 806-4 and EN 12502 should be observed when combining galvanised ferrous metals with other pipe materials. Larger components and units made of copper, copper alloys, tin plated copper and copper solder should not be placed upstream of such galvanised ferrous materials. Adaptors made of copper alloys, whose length is at least the diameter of the components, should be used as bridging components between stainless steel and galvanised parts. By doing so the contact corrosion – dependent on the water quality – is reduced.

EN 806-4  
Point.5

**Prevention/reduction of the build up of limescale**

Hard to very hard water reduces the lifespan of units and components in drinking water installations. In addition, it raises the energy consumption, because limescale on heating rods can affect heat transfer. In this case, it makes economic and ecological sense to take steps to soften the water. Depending on the process, it can be advisable to raise the pH-value of the water up to 7.7, which simultaneously provides corrosion prevention.

**Recommended treatment method for the prevention of the build-up of limescale in regards to the calcium concentration and temperature are given in the German standard DIN 1988-200, tabl. 6:**

Calcium concentration [mg/l]	Sanctions at t ≤60 °C	Sanctions at t ≥60 °C
< 80 Is equivalent to hardness level 1 and 2 <sup>1</sup>	None	None
80 to 120 Is equivalent to hardness level 3 <sup>1</sup>	None or stabilisation or softening	Stabilisation or softening recommended
120 Is equivalent to hardness level 4 <sup>1</sup>	Stabilisation or softening recommended	Stabilisation or softening

Tab. D – 1

**Viega Pipe system philosophy**

**Material recommendations**

**Service connection and earth-laid pipes made of PE**

- Press connectors made of gunmetal – corrosion-free (Geopress)
- Fast, safe and all weather sealing of the connection

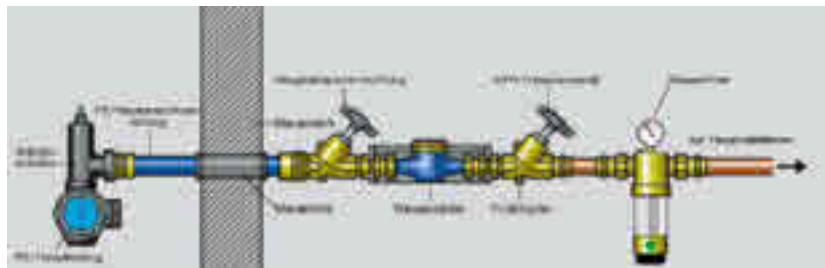

Fig. D – 4

<sup>1</sup> German law »Wash and cleaning products, §7«

**Drinking water connecton**

With Geopress

### Cellar manifold and riser pipes made of metal

- Good dimensional stability for modest fastening effort
- Saving of insulating material due to smaller external diameter
- Low elongation due to temperature change
- Can be pressed with a press tool up to DN 100
- Space saving



Fig. D – 5

### Storey distribution for PE-Xc pipes

- Optional with inlaid, welded aluminium layer
- Also with PE-protective pipe as condensation water protection
- For the endless laying from the roll onto the floor, in stand walls and in technology in front of the wall
- For pre-wall and dry construction technology, pre-assembled, noise de-coupled fitting connections singular, in rows or ring systems



Fig. D – 6

Drinking water distributor with Sanpress

**Bathroom installation**

Hygienic configuration of branch lines

**Pipe routing and water exchange**

Practical experience proves that in individual supply lines (branch lines) at frequently used extraction points in residential homes, no system-endangering microbial contamination is to be expected. In non-residential buildings, this should always be evaluated separately and in the individual case.

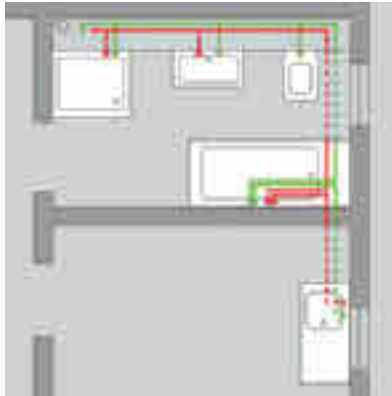

Fig. D – 7

In the preceding diagram, a typical drinking water installation of an apartment is shown. Standpipes are provided at extraction points such as the washbasin or shower. In comparison, the bathtub (also installed with a shower) is more seldom used and should, therefore, be connected to the sink using a series pipe. The same would apply for a bidet and washing machine connection. The latter is frequently installed but then later not operated within the apartment.

**Distribution of the loss in pressure**

Through the exact calculation of the losses in pressure all of the requirements for optimal soundproofing are fulfilled. With low pressure loss shut-off valves e.g. ball valves, it is possible to utilise the extra pressure potential. Further possibilities present themselves through the choice of electronic flow heaters instead of the hydraulic variety; draining valves with low minimum flow pressure etc. Manufacturer's listed pressure loss values should be taken as a guide instead of the general guidelines from regulations.

In accordance with EN 806-5, a drinking water installation is only considered to be operated properly if there is at least one water exchange in 7 days ( $\geq 1 \times / 7 \text{ d}$ ). This relates to the complete water exchange in all sections and in the drinking water heater.

It is important that extraction points which are rarely used still benefit from regular water change. They should be situated in the system in such a way that they still receive fresh water regularly, even when they are only used on a seasonal basis. This can be done by integrating the rarely used extraction point in a ring or serial pipe system.

**EN 806-5  
Point 7**

Extraction points which are rarely used include

- Garden/Garage piping system
- Guest-WC
- Kitchen
- Serial washer systems, e.g. in sports centres
- Bidet
- Planned connections for washing machines
- Tap connections for hoses in toilet units
- Sinks
- Heating filling and draining pipes



Fig. D – 8

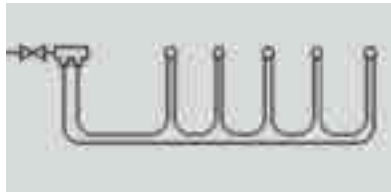

Fig. D – 9

#### Serial- and ring systems

For reliable water exchange.

#### Fire extinguishing and fire prevention units

Fire extinguishing and fire prevention units are important safety installations. If these units were combined with drinking water systems it could lead to problems with hygiene, if the system is not regularly used. This is nearly always the case. Therefore, fire extinguishing and fire prevention units must be separated from drinking water systems in compliance with the regulations.

#### Pipe network calculation

The aim of the pipe network calculation (e.g. acc. to EN 806-3) is an efficient function with economic pipe diameters. Minimum pipe widths and short branch lines lead to shorter standing times for the drinking water in the installation. They allow the necessary water change whilst using the minimum amount of water.

EN 806-3

#### Water exchange

Series pipes to extraction points with frequent use can economically ensure the necessary water exchange, even in upstream fittings with a low frequency of use. If a main consumer cannot be fitted to the end of a series pipe, the same safety objective is achieved using a loop pipework system. With this type of installation, a simply flushing by hand or using a flush system is sufficient in the case of interruptions to usage.

**Extraction point**

With low dead space

**Sample extraction points**

Configuration for orientation and wide reaching tests

Collecting and draining pipes should also be tested if present

National regulation e.g. DVGW W 551

see page 59 et sqq.

**O** = Orientation sampling

**W** = Continuous sampling

**Visign for Care – Hygiene flush function**

To prevent stagnation and with it microbial contamination, seldom used sections of piping systems must be flushed through regularly. The actuating panel »Visign for Care« is equipped with a hygiene flush function, which registers the interval during which no water has been drawn and actuates a flush in accordance with an individually programmable period of time.

Installation and upgrading is possible for Viega concealed cisterns with dual flush technology in serial or ring piping systems, if a 230V connection and an empty pipe for the control cable is available.

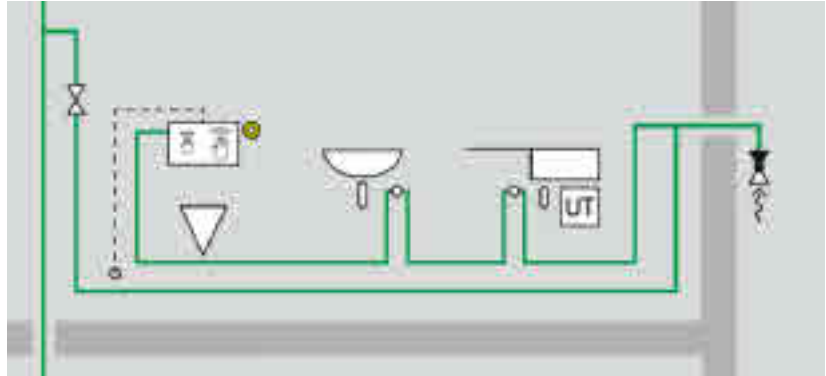

Fig. D – 10

**Sampling points**

Quality control of water in hospitals, hotels etc. makes sampling points meaningful. It is advisable to plan a number of sampling points in complex piping systems e.g. in the cellar manifolds, riser pipes and the floor distribution manifolds. Fig. D-4 gives example of sampling points.

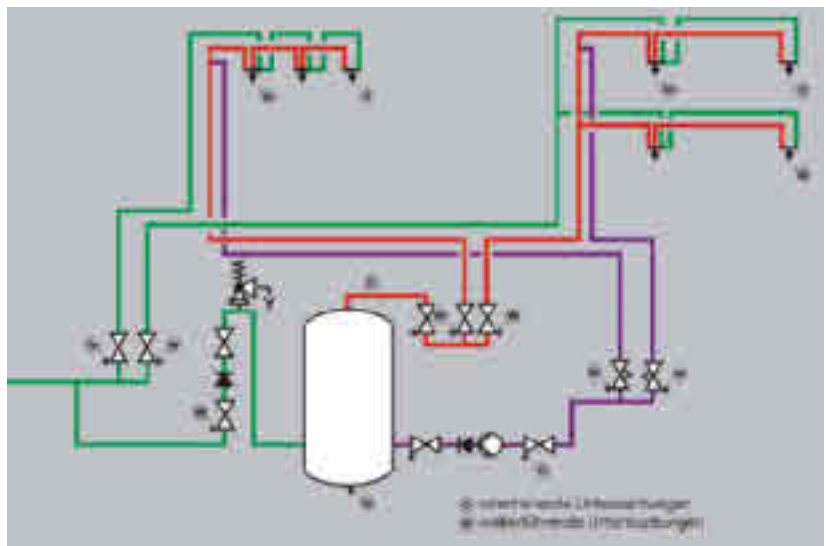

Fig. D – 11

### Overview of hygiene conscience planning and completion

When planning a drinking water (PW) installation the following criteria should be observed

- Material selection in compliance with EN 12502
- Use of approved products
- Determination of minimum water volume – use pressure potential
- Plan the maximum distance between drinking water cold (PWC) pipes and sources of heat
- Provide sufficient insulation for the drinking water hot/cold (PWH/PWC) pipes in ducts and lowered ceilings
- Do not install appliances for the secondary treatment of drinking water (PWC) in rooms with a temperature of  $>25^{\circ}\text{C}$  (e.g. boiler rooms)
- Set temperature should be determined in the drinking water heater and manifold
- Ensure hydraulic equalisation in circulation system
- Plan sampling points in public buildings
- Choose singular locking for backflow prevention
- If possible, do not fit a membrane expansion container in PW-systems
- Measures to minimise stagnation – e.g. no Bypass-pipes and drainage pipes, do not factor in reserves.
- Separate unused lengths from existing systems
- Separate fire extinguisher piping systems from drinking water systems
- Dry leakage test recommended (see page 25) in new installations or ensure water exchange every 7<sup>th</sup> day in period between wet water pressure test and regular operating

Long-term stagnation ( $> 7$  days) in combination with continuous temperatures between 25 and 55 °C must be avoided!

Drinking water systems consist of a number of singular components. Alongside the piping system, the securing of fittings and other components according to EN 1717 is of particular importance.



Fig. D – 12

**EN 806-4  
Point 7**

**Easytop-combined  
slanted seated valve**

With sample extraction  
valve



**Avoid residual water in components**

**Installation**

**Storage and assembly**

All components of a drinking water installation must be supplied to the building site in a hygienically flawless state. In the manufacturing processes, dry leakage tests are preferred in order to exclude any microbial risk in the products. With residual water in a fitting after a leakage test with water, it is possible that an increase in micro-organisms is promoted during long storage times in the summer months. For example, the drinking water installation of a clinic has had to be continually disinfected with chemicals since 2006 because the newly installed pressure booster system was supplied and commissioned with a *pseudomonas aeruginosa* contamination due to a wet leakage test in the factory.

The storage of pipes, moulds and fittings should always be carried out in a way that excludes any penetration of dirt and contaminated water. Due to the fact that building phases often last for long periods of time, the risk is great that a contamination can occur in the components even before the system is commissioned.



Fig. D – 13

Viega pipes are supplied fitted with stoppers so that hygienic transportation can be guaranteed. Protective caps for sealing riser pipes during assembly are required because the risk of penetration with dry cement dust and similar - particularly in shafts - must always be taken into consideration. Although such entries are normally considered to be

non-critical in terms of microbiology, the flushing output can still be really large in order to clean such deposits out of complex pipe networks for subsequent operation.

In comparison to this, repair works and system expansions can be far more critical in terms of hygiene. A qualified fitter should know that he must wash his hands thoroughly after working with contamination - e.g. in an existing drainage system - before he continues to work on a drinking water installation. As a result, the risks for drinking water quality and, as such, the safety objective of “health” should be considered more critical during work on old systems or in the case of operational breakdowns than during installation work in a new build. In this sense, the requirement for locally restricted repairs should be interpreted with regards the disinfection of components which are installed in existing pipes. For this reason, press connections should only be removed from the original packaging directly before use, meaning they require no disinfection.

**Risks when working on old systems**

EN 806-4  
Point 6.3.5

## Wet leakage test

### Procedure

- Test pressures
  - — Nominal widths  $\leq$  DN 50  $p_{\max} = 0.3 \text{ MPa}$  (3 bar)
  - — Nominal widths DN 50 – DN 100  $p_{\max} = 0.1 \text{ MPa}$  (1 bar)

A manometer with a reading accuracy of 100 hPa (0.1 bar) in the display range must be used.
- After achieving the test pressure, the test period is 10 minutes.
- During the test period, a visual inspection of all welded, soldered, press, clamp, plug-in, adhesive and screw connections takes place.

If a leakage is determined during the test, the stress test must be repeated after the repair.

After the impermeability has been assessed, the installation is ready for commissioning

## Dry leakage test

Unfortunately, this test method has not yet been incorporated into the EN 806-4. For this reason, we recommend the following test method in accordance with national regulations.

After assembly has been completed but before commissioning, the installation is initially checked for impermeability and then undergoes a stress test.

The following media should be used for the impermeability / stress test

- Oil-free compressed air
- Inert gases – e.g. nitrogen, carbon dioxide
- Forming gas with 5% hydrogen in nitrogen – for leak detection procedures

Safety-relevant equipment, such as a pressure reducing valve on compressors, must ensure that the intended test pressure is not exceeded.



Fig. D – 14

### Procedure

- Test pressure  $p = 150 \text{ hPa}$  (150 mbar) – Manometers with a reading accuracy of 1 hPa (1 bar) in the display range must be used – the established U-pipe manometer and stand pipes are permitted
- After achieving the test pressure, the test period for systems with
- a pipe volume of  $\leq 100$  litres should be at least 120 minutes – for each subsequent 100 litres of pipe volume, the test time should be extended by 20 minutes.
- All installation components must be rated for the test pressure or must be dismantled before the test.

The leakage test starts after the test pressure has been achieved - an appropriate waiting period for the adjustment of the medium temperature to the ambient temperature must be taken into consideration.

If a drop in pressure is determined during the test period, the leak must be rectified and the leakage test must be repeated. After impermeability of the installation has been determined, the stress test is carried out.

### Commissioning

#### General rules

- Before the system is filled for the first time, a leakage / stress test must be carried out.
- The installation or sections of it should only be filled when normal operation is directly imminent.
- If the start of operation is delayed or not carried out fully, then hygienic risks should be ruled out by ensuring sufficient water through-put on the basis of flushing schedules or automated flushing systems – the procedure must be documented.
- The planning criteria (pipe routing etc.), logs of leak and stress tests, flushing and briefings, etc., must be given to the operator together with the instructions.
- The operator must be made aware of the necessity of regular, complete water through-put, e.g. three times a week in buildings with medical usage.
- The risk of microbial stress / contamination caused by too low temperatures in hot water and too high temperatures in cold water must be explained to the operator.
- A maintenance plan should be given to the operator and a maintenance contract should be offered.

## Disinfection

For components in drinking water installations, such as pipes and connectors, the life span in normal use is more than 50 years. During this time, the unavoidable, elapsing processes in the drinking water range with metals, elastomers and plastics lead to an “aging” without causing damage.

Oxidative stress, e.g. through high doses of disinfectant, can accelerate this aging process, leading to the product breaking down.

Fortunately, such high doses of disinfectant only occur in cases of average, and therefore rarely. To ensure long-lasting flawless water quality, the cause of the problems must be determined and rectified. Persistently absent success with disinfection in the long term is always a definite sign that the actual contamination source has not been found or rectified. For this reason, the following must apply

- All materials currently used in the drinking water installation for components such as pipes and connectors can be disinfected with the licensed disinfectants in the stated concentrations, times and at the stated temperatures.
- Components with elastomers for sealant elements can also be disinfected as below. For large-scale contact with an elastomer, the guidelines and requirements of the manufacturer must be taken into consideration.
- To protect against excessive exposure times, the installation must be flushed after each disinfection until the water quality corresponds to the non-disinfected drinking water again.
- All measures must be documents and the documentation must be archived by the operator.
- If the above conditions are complied with, components of the drinking water installation are considered to be sufficiently resistant, even from disinfection.

**Risk**  
**Material »aging«**

**EN 806-4**  
**Point 6.3**

Installation with  
Sanpress Inox

### Cost effectiveness of pipe systems

The choice of the right pipe material for a drinking water installation is made using technical and economic aspects. Alongside long-term safety and hygiene, the assembly friendliness and economic factors play a deciding role.

As regards user friendly assembly and handling, press technology offers the biggest economic advantages; further deciding factors are the availability, range and cost of the piping system's fitting and fasteners. In the field of cellar manifolds and riser pipes, metal pipes, as opposed to plastic pipes, are the preferred option.



*Fig. D – 15*

The advantages are

- Less space required for elongation
- Minimum expansion bend and compensation bend expense
- Reduction in fastening material
- Less stringent requirements for preventive fire protection
- Less money needs to be spent on thermal insulation thanks to minimum pipe wall thicknesses (large pipe diameters in particular)

*Fig. D-15* shows the different sanctions required for the compensation of elongation of various materials. Metallic piping systems offer a clear advantage. The same is true for the work required for fastening, which is 50 % or more lower in the field of cellar manifold and riser pipes.

In contrast, on the floors and in pre-wall installations only small diameters and shorter pipe lengths are required. The elongation is therefore low and the fastening work for earth laid pipes is minimal.

Therefore, combining the two systems – metallic cellar distributing pipes and riser pipes and plastic floor distributing pipes – will maximise assembly benefits and costeffectiveness.

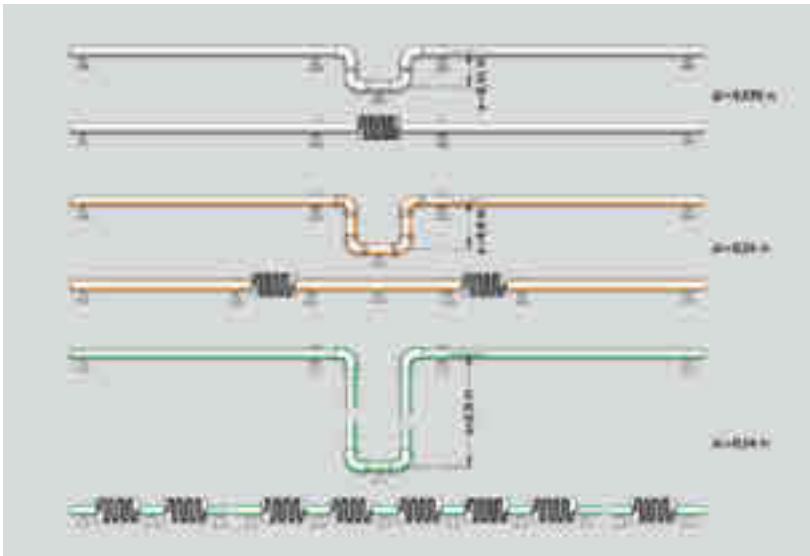

Fig. D – 16

Further influences on the costeffectiveness are

- The price of pipes, fastening elements and insulation
- Assembly work (dependent on material) including wages and non-wage labour costs
- Pipe diameters, the effort required for the fastening and the compensation of thermal elongation
- Proven safety and quality of the products – SC-Contur
- Tool costs
- Inventory
- Quick availability from suppliers

## Overview of metallic pipe systems

### Press connectors-Approved quality with SC-Contur



Fig. D – 17

#### Sanpress Inox

Pipe Stainless steel  
Press connector Stainless steel 15–108.0 mm

For all types of drinking water without restrictions.

Highest quality of material



Fig. D – 18

#### Sanpress

Pipe Stainless steel  
Press connector Gunmetal 12–108.0 mm

For all types of drinking water without restrictions.

High resistance to chloride



Fig. D – 19

#### Profipress

Pipe Copper  
Press connector Copper 12–108.0 mm

**Observe restrictions on use with drinking water!**

# System descriptions

## Sanpress Inox/Sanpress Inox XL

### Intended use

The system has been designed for

- Drinking water not restricted under the terms of the European Drinking Water Ordinance
- Operating temperature 85 °C;  $T_{\max} = 110\text{ °C}$
- Operating pressure  $p_{\max} \leq 16\text{ bar}$

Protect the components against high concentrations of chloride generated both by the medium and by external factors. To prevent damage, do not store stainless steel pipes on concrete floors or pull over loading sills. Mixed installations are permissible, independent of flow direction. Before using Sanpress Inox/Sanpress Inox XL in any other applications than those described, contact Viega Service Center.



Fig. D – 20



Fig. D – 21



Fig. D – 22

### Stainless steel pipes

With stainless steel press connectors

Standard sizes  
12 – 54 mm

XL-sizes  
64.0 – 108.0 mm  
with compression ring  
and EPDM-sealing  
element



**Pipe material**

 Identical to Sanpress  
Ref.-standard EN 10312

**Press connector material**
**Sealing element**
**Delivery condition**
**Approvals**

System

**Nominal sizes [mm]**

Sanpress Inox

Sanpress Inox XL

**Technical data**

Sanpress Inox- and Sanpress Inox XL- stainless steel pipes – thin-walled and corrosion resistant stainless steel pipes

- Material no. 1.4401 (X5 CrNiMo 17-12-2), with 2.3 % Mo for higher durability; identification marking yellow plugs
- Material no. 1.4521 (X2 CrMoTi 18-2), PRE-value 24.1; identification marking green plugs

Stainless steel

Black; EPDM (ethylene propylene diene rubber); up to 110 °C; not resistant to hydrocarbon solvents, chlorinated hydrocarbons, turpentine, petrol.

- Bars 6 m in length, with bright-finished external and internal surfaces
- Plastic plugs on pipe ends
- All pipes are leak-tested and marked as such

Pipe material no. 1.4401:

 DVGW approval: DW-8501BL0551                      15 – 54 mm  
    DW-8511BQ0245                      64.0 – 108.0 mm

Pipe material no. 1.4521: DVGW approval: DW8501BS0376 (15 – 108.0 mm)

15/18/22/28/35/42/54

64.0/76.1/88.9/108.0

**Sanpress Inox-pipes**

d x s	Volume per cons. metre of pipe	Weight per cons. metre of pipe	Weight per 6m length	Size	Material Press connector
[mm]	[Liter/m]	[kg/m]	[kg]		
15 x 1.0	0.13	0.35	2.10	Standard	Stainless steel
18 x 1.0	0.20	0.43	2.55		
22 x 1.2	0.30	0.65	3.89		
28 x 1.2	0.51	0.84	5.02		
35 x 1.5	0.80	1.26	7.55		
42 x 1.5	1.19	1.52	9.13		
54 x 1.5	2.04	1.97	11.83		

**Sanpress Inox XL-pipes**

64.0 x 2.0	2.83	3.04	18.24	XL	Stainless steel
76.1 x 2.0	4.08	3.70	22.20		
88.9 x 2.0	5.66	4.34	26.00		
108.0 x 2.0	8.49	5.30	31.80		

Tab. D – 2

## Sanpress/Sanpress XL

### Intended use

The system is designed for

- Drinking water not restricted under the terms of the German Drinking Water Ordinance
- Operating temperature 85 °C;  $T_{\max} = 110\text{ °C}$
- Operating pressure  $p_{\max} \leq 16\text{ bar}$

Protect against high concentrations of chloride generated both by the medium and by external factors. Mixed installations are permissible, independent of flow direction. Before using Sanpress XL in any application other than those described, contact Viega Service Center.



Fig. D – 23



Fig. D – 24



Fig. D – 25

### Stainless steel pipes with gunmetal press connectors

Standard sizes  
12 – 54 mm

XL-sizes  
76.1 – 108.0 mm  
with compression ring  
and EPDM-sealing  
element

### Sanpress

Press connector system with stainless steel pipes

Press connectors made of gunmetal with EPDM-seal  
12 – 54 mm

All sizes with  
SC-Contur

**Pipe material**

Ref.-standard EN 10312

**Technical data**

Stainless steel pipes thin-walled and corrosion-resistant stainless steel pipes

- Material no. 1.4401 (X5 CrNiMo 17-12-2), with 2.3 % Mo for higher durability; identification marking yellow plugs
- Material no. 1.4521 (X2 CrMoTi 18-2), PRE-value 24.1; identification marking green plugs

**Press connector material**

Gunmetal

**Sealing element**

Black; EPDM (ethylene propylene diene rubber); up to 110 °C; not resistant to hydrocarbon solvents, chlorinated hydrocarbons, turpentine, petrol.

**Delivery condition**

- Bars 6 m in length, with bright-finished external and internal surfaces
- Plastic plugs on pipe ends
- All pipes tested for leakage and marked as such

Constantly controlled both in-house and by the NRW material testing inspectorate.

**Approvals**

System

Pipe material no. 1.4401: DVGW approval:

- DW-8501AP3032      12 – 54 mm
- DW-8501AT2348      76.1 – 108.0 mm

Pipe material no. 1.4521: DVGW approval:

- DW-8501BS0377      12 – 108.0 mm

EN 10088: General requirement for welded circular pipes made from non-corroding stainless steels.

DVGW-specification W 541: non-corroding stainless steel pipes for drinking water supply systems DVGW-test symbol TS 233 (N 012)

**Nominal sizes [mm]**

Sanpress Inox

12/15/18/22/28/35/42/54

Sanpress Inox XL

76.1/88.9/108.0

**Sanpress-pipes**

d x s [mm]	Volume per cons. metre of pipe [Liter/m]	Weight per cons. metre of pipe [kg/m]	Weight per 6m length [kg]	Size	Material Press Connector
12 x 1.0	0.08	0.27	1.60	Standard	Gunmetal
15 x 1.0	0.13	0.35	2.10		
18 x 1.0	0.20	0.43	2.55		
22 x 1.2	0.30	0.65	3.89		
28 x 1.2	0.51	0.84	5.02		
35 x 1.5	0.80	1.26	7.55		
42 x 1.5	1.19	1.52	9.13		
54 x 1.5	2.04	1.97	11.83		

**Sanpress-XL-pipes**

76.1 x 2	4.08	3.70	22.20	XL	Gunmetal
88.9 x 2.0	5.66	4.34	26.00		
108.0 x 2.0	8.49	5.30	31.80		

Tab. D – 3

## Profipress/Profipress XL

### Intended use

Copper pipes and connectors can only be used without restrictions for drinking water, if

- the pH-value is 7.4 or higher or
- the TOC value does not exceed 1.5g/l at pH levels between 7.0 and 7.4

The system has been designed for

- Operating temperature  $\leq 85\text{ }^{\circ}\text{C}$ ;  $T_{\text{max}} = 110\text{ }^{\circ}\text{C}$
- Operating pressure  $p_{\text{max}} = \leq 16\text{ bar}$

Copper components must not be installed upstream of galvanised iron materials.

Before using Profipress in any application other than those described, contact Viega Service Center.

**Observe water quality!**

**Observe flow rule!**



Fig. D – 26



Fig. D – 27

### Profipress-connectors

Standard sizes  
12 – 54 mm

XL-sizes  
64.0 – 108.0 mm  
with compression ring  
and EPDM-sealing  
element



Fig. D – 28

### Connectors

With Press and  
threaded joint

All sizes with  
SC-Contur

**Pipe material**
**Technical data**

Only copper pipes compliant with EN 1057 may be used. Please Regard the minimum wallthickness acc. to Tab. D-4

**Press connector material**

- 12 – 108.0 mm copper
- Press connectors with threaded joint
  - 12 to 54 mm gunmetal
  - 64.0 to 108.0 mm copper

**Sealing element**

Black; EPDM (ethylene propylene diene rubber); up to 110 °C; not resistant to hydrocarbon solvents, chlorinated hydrocarbons, turpentine, petrol.

**Approvals**

Profipress with SC-Contur DVGW-Reg.-Nr. DW-8511AP3139

**System**

Profipress XL DVGW-Reg.-Nr. DW-8511AT2347

**Sizes [mm]**

Profipress

12/15/18/22/28/35/42/54

Profipress XL

64.0/76.1/88.9/108.0

**Approved copper pipes**

d x s [mm]	Volume per running metre of pipe [Liter/m]	Weight per running metre of pipe [kg/m]	Weight per 5m rod [kg]	Size	Material press connector
12 x 0.8	0.09	0.25	1.54	Standard	Copper
12 x 1.0	0.13	0.39	1.54		
15 x 1.0	0.13	0.39	1.96		
18 x 1.0	0.20	0.48	2.38		
22 x 1.0	0.31	0.59	2.94		
28 x 1.0	0.53	0.76	4.54		
28 x 1.5	0.49	1.11	5.55		
35 x 1.2	0.84	1.13	6.80		
35 x 1,5	0.80	1.41	7.05		
42 x 1.2	1.23	1.37	8.21		
42 x 1.5	1.2	1.70	8.50		
54 x 1.5	2.04	2.20	13.21		
54 x 2.0	7.97	2.91	14.55		

**XL-pipes**

64.0 x 2.0	2.83	3.47	17.34	XL	Copper
76.1 x 2.0	4.08	4.14	20.72		
88.9 x 2.0	5.66	4.86	24.30		
108.0 x 2.5	8.33	7.37	36.87		

Tab. D – 4

# Application technology

## Insulation\*

Depending on the application and pipe material, the insulation, laying and fastening of the pipes according to the technical regulations is necessary for the following reasons

- Protection against the build-up of condensation
- Prevention of external corrosion
- Preservation of drinking water quality
- Limitation of heat loss
- Prevention of noise due to elongation
- Protection against the transfer of pressure surges onto the structure
- No transfer of flowing noises

## Cold water pipes

Drinking water piping systems (cold) must be insulated to avoid heat loss and condensed water formation.

The pipes must be located a sufficient distance away from heat sources such as hot pipes, chimneys, heating installations. If this is not possible, cold water pipes must be insulated to prevent impairment of drinking water quality as a result of heating.

**Guide values for minimum insulation layer thicknesses– cold water**

Mounting situation	Insulating layer thickness at $\lambda = 0.040 \text{ W/(mK)}$ [mm] <sup>1</sup>
Exposed pipes, non-heated floor space	4
Exposed pipes, heated floor space	9
Pipes in the duct, without pipes which get hot	4
Pipes in the duct, adjacent to pipes that become hot	13
Pipes in the wall slot, riser pipes	4
Pipes in the wall cut-out, adjacent to pipes that become hot	13
Pipes on concrete ceiling	4

Tab. D – 5

<sup>1</sup> For other thermal conductivities, insulating layer thicknesses must be converted based on a diameter  $d = 20 \text{ mm}$

### Drinking water piping systems (PWH)\*

Please use the values in the following tables to minimise the heat emission of hot water piping systems compliant with EnEV requirements.

National regulations should be observed.

#### Minimum insulation layer thicknesses

	Type of pipe/fitting	Minimum insulating layer thickness based on a heat conductivity of 0,035 W/(m·K)
1	Internal diameter up to 22 mm	20 mm
2	Internal diameter over 22 up to 35 mm	30 mm
3	Internal diameter over 35 up to 100 mm	Equal to internal diameter
4	Internal diameter over 100 mm	100 mm
5	Pipes and fittings as per rows 1–4 – in wall and ceiling lead-ins – at line crossings – at line connection points – with central line grid manifolds	50 % of the requirements acc. to row 1–4
6	Piping systems from central heating according to lines 1 to 4, which were fitted between heated rooms with different users after this ordinance came into effect	1/2 the requirement from lines 1 to 4
7	Piping systems according to line 6 in floor construction	6 mm
8	Cooling distribution and cold water pipes, as well as fittings from room air technology and air cooling systems	6 mm

Tab. H – 1

Except for branch lines (piping systems out with the water circulation and which are not equipped with electrical heating). Pipes with an internal diameter of 22 mm or less, are not subject to the minimum insulating layer.

### Noise protection

Noises in drinking water installations mainly originate from fittings and sanitary objects. The noise can be carried audibly through the piping system and transferred onto the structure, which then produces the airborne noise.

The following measure may help to prevent this

- Use of low-noise fittings
- Reduction of the water pressure
- Proper fastening of the pipes
- Compliance with the minimal intervals between pipes regarding elongation
- Pipes are fitted with noise insulation elements thus preventing the transfer of pressure surges onto the structure

## Fire protection\*

If pipes are fed through ceilings and walls in different fire zones, suitable action must be taken which delays the fire from spreading for a definite period of time. Shafts with pipes insulated with rockwool, together with layer of poured concrete in the gaps and floor level have proven effective. This allows for a professional separation of the pipes from the rest of the construction.



Fig. D – 29

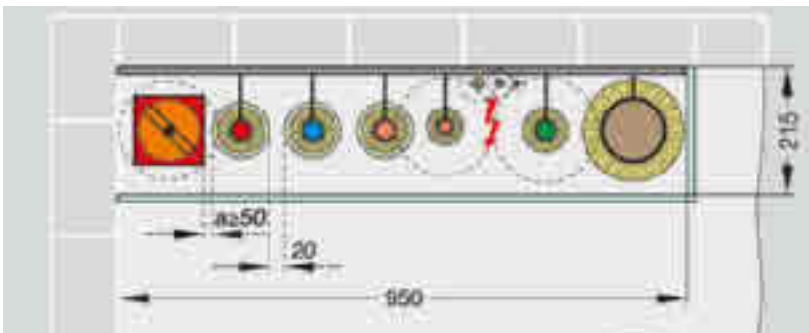

Fig. D – 30

Also there are no prescribed minimum distances between the insulated pipes, it is recommended to leave at least 20 mm for the boring of holes. The same is true for an open shaft closed by the pouring of a concrete sealant.



**Steptec-  
installation shaft**

**Prevention of fire  
transfer**

Closed ceiling construction with shaft filled with pipes insulated with rockwool in a plasterboard casing



## Elongation – compensating members

Thermal expansions in installation systems generate stresses in pipes and appliance connectors. It is for this reason that compensation bends or expansion compensating members need to be fitted to long stretches of pipe.

Expansion compensating members are stretches of pipe with U or Z-shaped expansion bends which are able to absorb movement on account of their length and fastening method.

### U- or Z-expansion compensating members

If the installation conditions facilitate the use of U- or Z-expansion compensating members, proceed as follows to calculate the associated expansion bend lengths:

1. Determine the maximum possible temperature difference  $\Delta T$
2. Identify the length of the pipe  $l_0$

These values are used to calculate the total length which the section of pipe extends by the diagrams on the following pages illustrate the necessary pipe bend length  $L_{BZ}$  or  $L_{BU}$  for each pipe.

#### Example (see following pages)

1. The operating temperature is between 10 and 60 °C – therefore:  
 $\Delta T = 50 \text{ K}$ .
2. The section of pipe is:  $l_0 = 20 \text{ m}$ .
3. The length expansion coefficient for stainless steel pipe is:  
 $\alpha = 0.0165 [\text{mm/mK}]$ .
4. Insert the values into the formula:  
 $\Delta l = \alpha [\text{mm/mK}] \cdot L [\text{m}] \cdot \Delta T [\text{K}]$

#### Result

The length expansion:  $\Delta l = 0.0165 [\text{mm/mK}] \cdot 20 [\text{m}] \cdot 50 [\text{K}] = 16.5 \text{ mm}$

5. Select a U- or Z-bend depending on the space available.
6. Take the necessary expansion bend length  $L_{BZ}$  from the U or Z diagram.  
In this example for Z-expansion bend:

Go along the vertical axis at 16.5 mm horizontal to the line indicating the pipe size used and read the necessary expansion bend length from the horizontal axis below.

At the selected pipe nominal width  $\text{Ø}28 \text{ mm}$ , the expansion bend length  $L_{BZ} = 1.3 \text{ m}$ .

## Elongation of various materials

	Heat expansion-co-efficient $\alpha$ [mm/mK]	Elongation with pipe length = 20 m and $\Delta T = 50\text{K}$ [mm]
Stainless steel 1.4401	0.0165	16.5
Stainless steel 1.4521	0.0108	10.8
Galvanised steel	0.0120	12.0
Copper	0.0166	16.6
Plastic	0.08 – 0.18	80.0 – 180.0

Tab. D – 6

## Elongation of stainless steel pipes

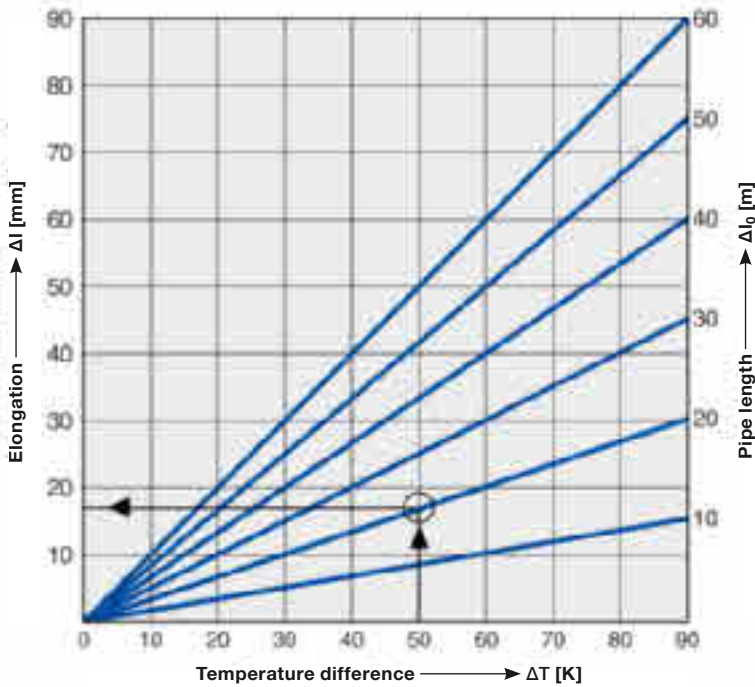

Fig. D – 31

 Elongation  
of various materials

Calculating length of expansion bends for pipes  $\varnothing < 54$  mm

**Expansion bend**

Z-form with expansion bend  $L_{BZ}$  and as tee connection



Fig. D – 32

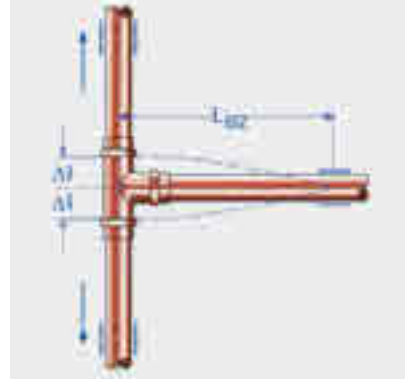

Fig. D – 33

**Length calculation**

of expansion bends in Z- and T-form

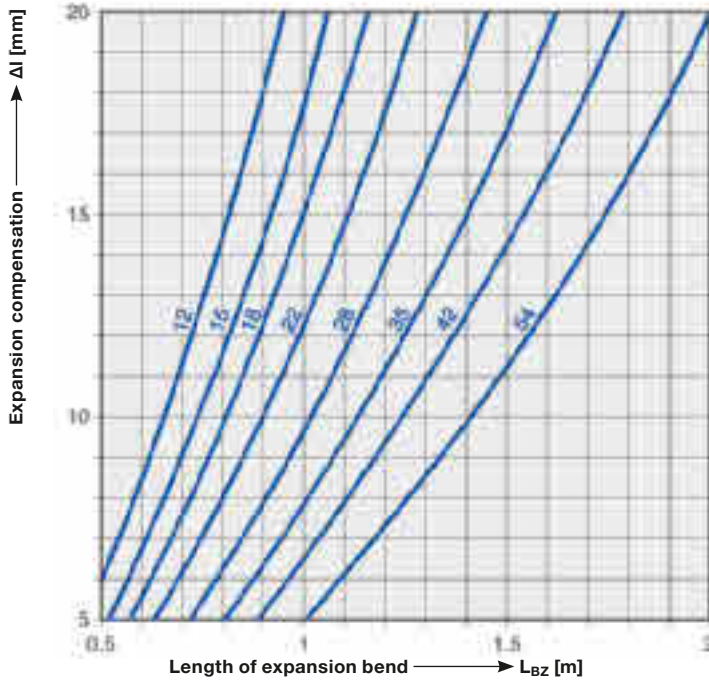

Fig. D – 34

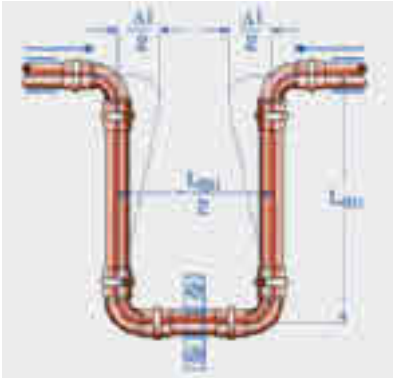

Fig. D – 35

**Length of expansion bend**

In U-form with expansion bend  $L_{BU}$

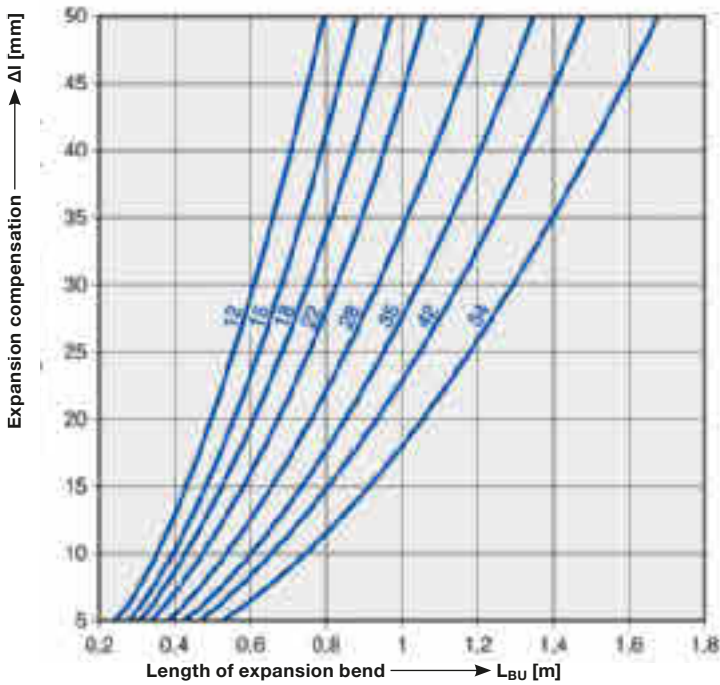

Fig. D – 36

**Length calculation**

For expansion bends in U-form

Calculating length of expansion bends of pipes  $\varnothing > 54$  mm

**Expansion bend**

In Z-form with expansion bend  $L_{BZ}$  and as tee connector



Fig. D—37  
Z expansion compensating bend with XL-connector

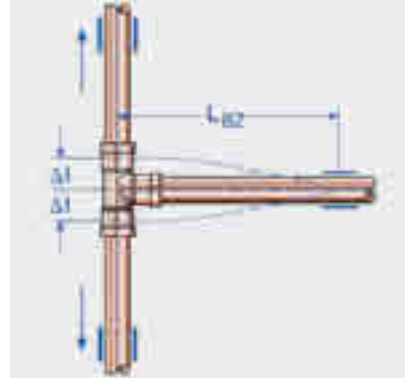

Fig. D—38  
Expansion compensation length of pipe bend

**Length calculation**

For expansion bend in Z- and T-form

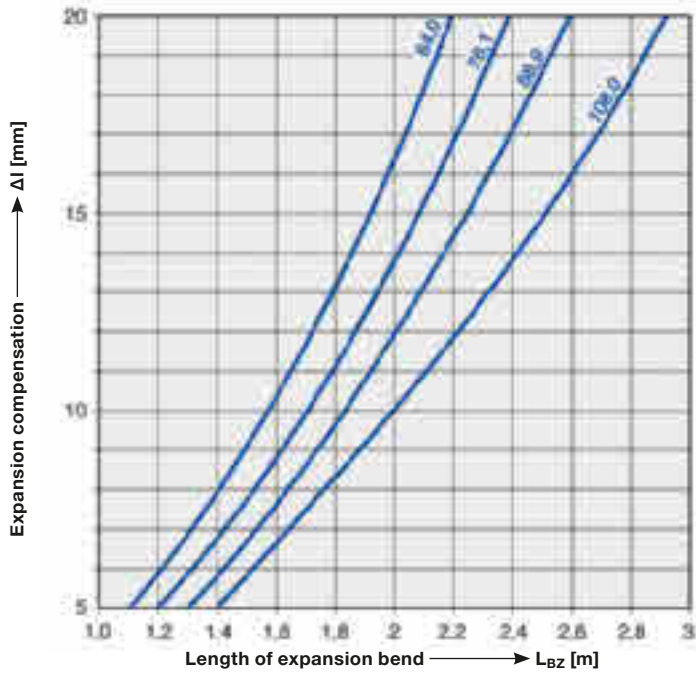

Fig. D—39

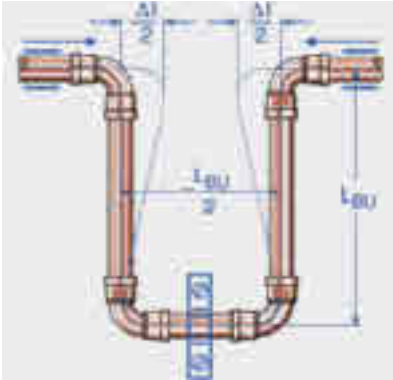

Fig. D – 40

**Expansion bend**

U-form with expansion bend  $L_{BU}$

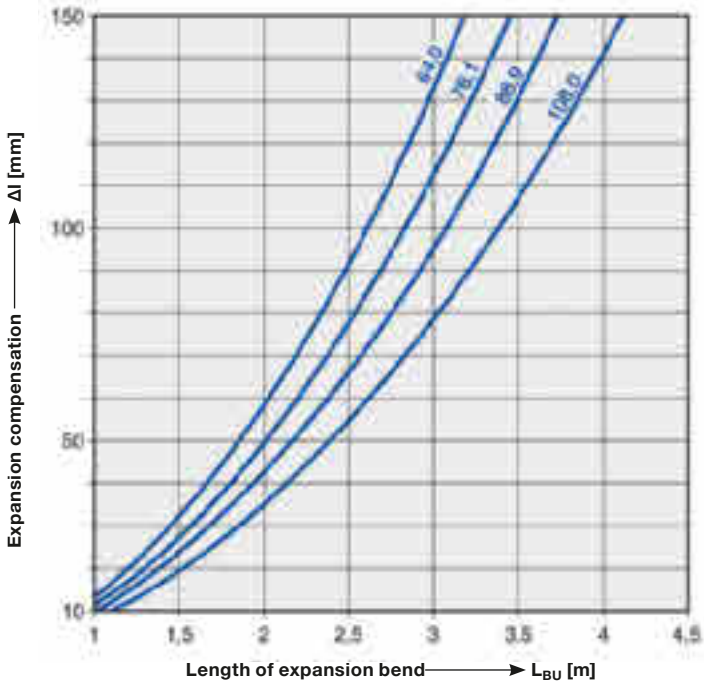

Fig. D – 41

**Length calculation**

For U-form expansion bend

**DIN EN 806-2**  
**Point 6.2**

**Axial compensator**

Sizes 15 – 54 mm

**Axial compensator**

The alternatives to expansion joints are compensators. They are suitable for absorbing axial movements in the pipe installations with operating temperatures between 20 and 110 °C.



*Fig. D – 42*

- A space-saving alternative to expansion compensating members
- No pre-stressing required
- Noise-reducing
- Durable and resistant to corrosion
- Suitable for mixed installations

**Assembly information**

The pipes must be attached in such a way that unpermitted radial and torsional stresses are avoided. Fastening points must be assessed in such a way that they can absorb considerable forces arising through temperature-related changes in length. It is important to ensure the correct alignment of fixing points and sliding pipe routings.

- Install pipes in straight lines
- Remove any radial and torsional stress
- Only one compensator may be fitted between two fixing points
- Do not use compensators for changes in direction
- Protect stainless steel bodies from mechanical damage

## Technical data

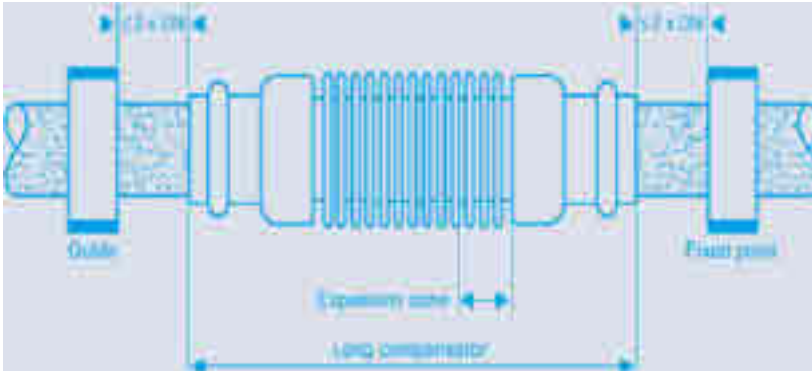

Fig. D – 43

**Z-dimension compensator**

Compensator d <sub>i</sub> /DN	Pressure [bar]	Effective body cross section A [cm <sup>2</sup> ]	Maximum fixing point load F <sub>max</sub> [N]	Expansion compensation <sup>1</sup> [mm]
15/12	10	3.10	620	-7
18/15	10	3.97	794	-9
22/20	10	6.15	1230	-11,5
28/25	10	9.02	1814	-14
35/32	10	13.85	2770	-13
42/40	10	20.42	4048	-15,5
54/50	10	30.90	6180	-16

Tab. D – 7

**Fixed Points / Gliding Points Function**

Fixed points connect the pipes firmly with the supporting structure and guide the expansion movement in the desired direction.

A pipe which is not interrupted by a change in direction or one which does not contain an expansion joint only has to contain one fixed point. In the case of long pipes, the recommendation is to position these fixed points in the centre of the segment so that the expansion is steered in two directions.



Fig. D – 44



Fig. D – 45

**Dimensions**

 Ø d<sub>i</sub> 15 – 54 mm

<sup>1</sup> Positioning: 10,000 full movement cycles at the nominal pressure, installation temperature

**Fixed point fastening**
**Gliding point fastening**

Gliding points facilitate axial movements



## Loss of pressure in pipes

The following diagram can be used to determine sufficiently precise values for pressure

loss due to pipe friction for copper and for stainless steel.

For the calculation of more complex water and circulation piping systems the use of specialised software, e.g. Viptool Engineering is recommended.

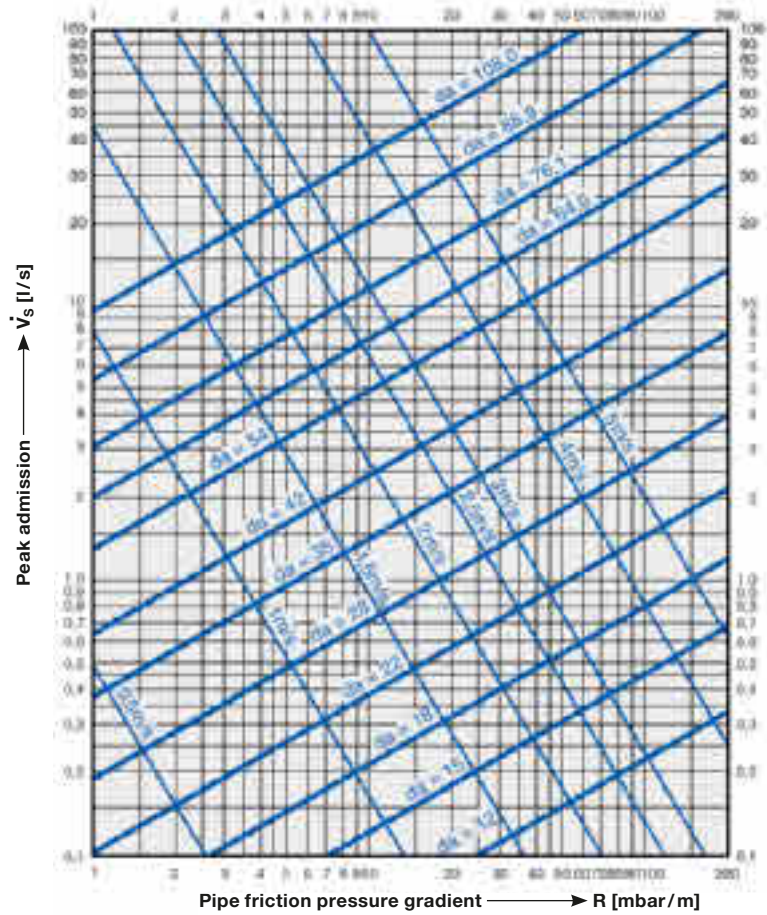

Fig. D – 46

$\dot{V}_s$  = Peak admission;  $v$  = peak flow rate;  $R$  = pipe friction pressure gradient

## Corrosion of stainless steel pipes caused by chloride

Excess chloride can corrode stainless steel pipes in drinking water supply systems.

It is for this reason that the following factors need to be taken into account

- Insulating materials must not exceed a percentage by weight of water-soluble chloride ions of 0.05 %
- Sound insulation inserts for pipe clamps must not contain any diffusing chloride
- Stainless steel pipes must not come into contact with materials containing chloride
- Stainless steel pipes exposed to gases or vapours containing chloride (in paint shops or surface treatment (HDG) facilities) must be protected by a plastic coating compliant with national guidelines

On average, a chloride content of 150 mg/l in drinking water is considered higher than average. The majority of drinking water regulations set a limit value for chloride of 250 mg/l. This »chloride« is not a disinfectant but a component of sea salt and cooking salt (NaCl). With chloride contents of up to 250 mg/l, Sanpress and Sanpress Inox are suitable for use in drinking water supplies compliant with the majority of drinking water regulations.

**Always avoid external contact with chloride**

**Concentration of chloride in drinking water**

## Components

### Easytop-slanted seated valves

Easytop-slanted seated valves made of gunmetal or stainless steel allow the direct press connection – without adapter – onto the Viega pipe systems Sanpress Inox, Sanpress and Profipress for drinking water installations.

Their construction as free flow valves prevents surges when used and help to protect the fittings, appliances and pipe installations fitted to them.

All types of Easytop valves comply with EN 1213: 1999 (Fitting group 1) and are available as

- Free flow valve
- Free flow valve with backflow preventer
- Backflow preventer

### Easytop-slanted seated valve

With SC-Contur

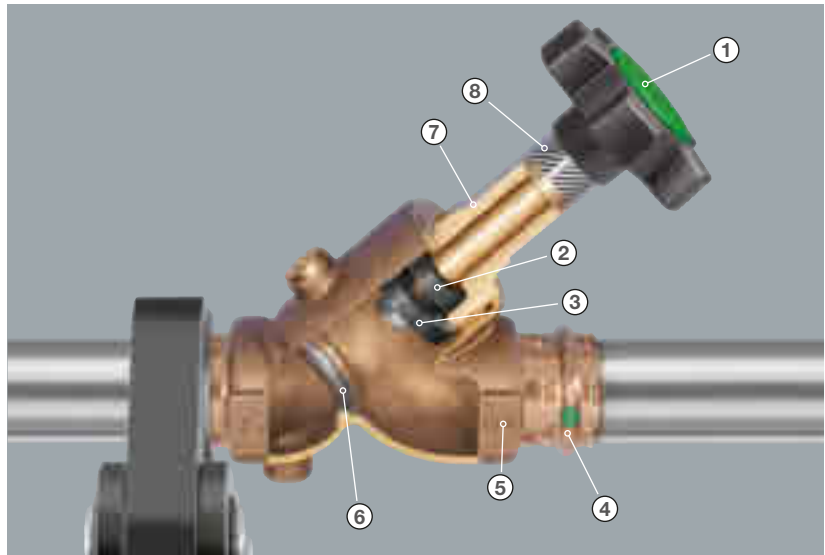

Fig. D – 47

- |  |                                   |
|--|-----------------------------------|
| ① Medium code on hand wheel                | ⑤ Gunmetal valve housing and body |
| ② Spindle seal EPDM                        | ⑥ Stainless steel valve seat      |
| ③ Gunmetal valve disk with EPDM valve seal | ⑦ Spindle                         |
| ④ Press connector with SC-Contur           | ⑧ Position indicator              |

**Areas of use**

Valve material	Material	Press connector system
Easytop Inox-slanted seated valve	Stainless steel	Sanpress Inox
Easytop-slanted seated valve	Gunmetal	Sanpress/Profipress

Tab. D – 8

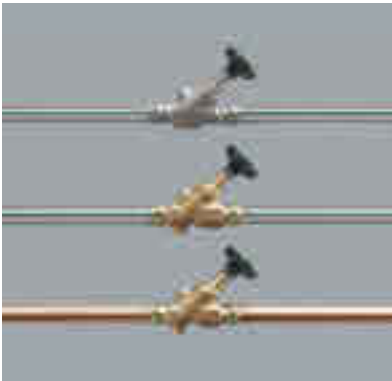

Fig. D – 48



Fig. D – 49

**Easytop-slanted seated valve**

- For the Systems
- Sanpress Inox
  - Sanpress
  - Profipress

**Easytop-slanted seated-valve types**

- Slanted seated valve
- Combined slanted seated valve (CCV)
- Backflow preventer

### Technical data – Versions

- For all types of drinking water
- Comforms to DVGW-AB-W270 and the KTW-recommendation
- Sizes 15 – 54 mm metallic systems, sizes 16 – 63 mm PE-Xc systems
- All Press connectors with SC-Contur
- Male thread acc. EN ISO 228-1, sizes DN 15 – DN 50
- Noise protection Lap  $\leq 20$  dB (A)
- Operating temperature  $T_{\max} = 90^{\circ}\text{C}$
- Operating pressure  $p_{\max} = 16$  bar

### Advantages

- Spindle seal maintenance free
- Space saving construction due to the non-rising spindle
- Erosions proof stainless steel valve seat
- Valve upper part with reduced stagnation space
- Simple storage, because accessories can be delivered separately
- Precise actuation due to servo technology
- Cover with key surfaces for easy installation
- Low pressure loss

### Accessories

The following accessories are available for Easytop-slanted seated valves

- Easytop-insulating sleeve
- Easytop-draining valve (steel and gunmetal)
- Easytop-extension piece (Stainless steel and gunmetal)

Easytop-  
drain valve

Easytop-  
extension piece



Fig. D – 50



Fig. D – 51

### Insulating sleeves

The self-securing insulating sleeves are available in all sizes and fit all Easytop-slanted seated valve variations.

The thickness of the EPP insulating material (expanded polypropylene) fulfils the requirements of the EnEV (Energy efficiency ordinance, Germany)\*.

Easytop-slanted seated valves with drain valves can be fitted with insulation sleeves. In this case an extension piece made of gunmetal or stainless steel is inserted.

Predetermined breaking points on the insulating sleeve allow an easy adaptation to the construction method being used. The insulation of the pipe system joins seamlessly to the flat side of the insulating sleeve.



Fig. D – 52



Fig. D – 53

### Easytop-slanted seated valve

Accessories:

Insulating sleeve with predetermined breaking points for drain valves

Insulating sleeve and insulated piping system

**Easytop Innox-slanted seated valve**

Installation in a cold water manifold



*Fig. D – 54*

**Easytop-slanted seated valve**

DW-Service connection piping system with Easytop water meter connecting plate



*Fig. D – 55*



**Easytop-  
slanted seated valves**

Hot water manifold with Easytop-slanted seated valve and circulation control valve (CCV) without insulating sleeve

Fig. D – 56



**Easytop XL–  
slanted seated valves**

Installation length  
according to  
DIN EN 558-1

**Easytop XL-slanted seated valves with flange connection**

Easytop XL-slanted seated valves with flange connection according to DIN EN 1092-1 are mainly used in distributor systems or as a shut-off unit in cold and hot water installations.

A transfer flange makes the transfer to the metallic Viega press connector systems Sanpress Inox XL, Sanpress XL and Profipress XL possible.



Fig. D – 57

**Technical data**

- DN 50, 65, 80, 100
- Sizes noise protection  $L_{ap} \leq 20 \text{ dB (A)}$
- Operating temperature  $T_{max} = 90 \text{ °C}$
- Operating pressure  $p_{max} = 16 \text{ bar (PN 16)}$
- Installation in indicated flow direction

**Characteristics**

- Drinking water installations hot and cold
- Casing made of gunmetal
- Fixed flange according to DIN EN 1092-1
- Valve seat made of stainless steel
- Drain plug and sampling point
- Spindle and shutter seal made of EPDM maintenance free
- Valve upper part free of stagnation space
- Non-rising spindle system
- Position indicator open/closed
- Medium indicator on the handle (green/red)
- Precise actuation with servo technology

**Accessories**

- Drain valve G 1/4 ( $\leq \text{DN } 50$ ), G 3/8 ( $\geq \text{DN } 65$ )

Examples of use

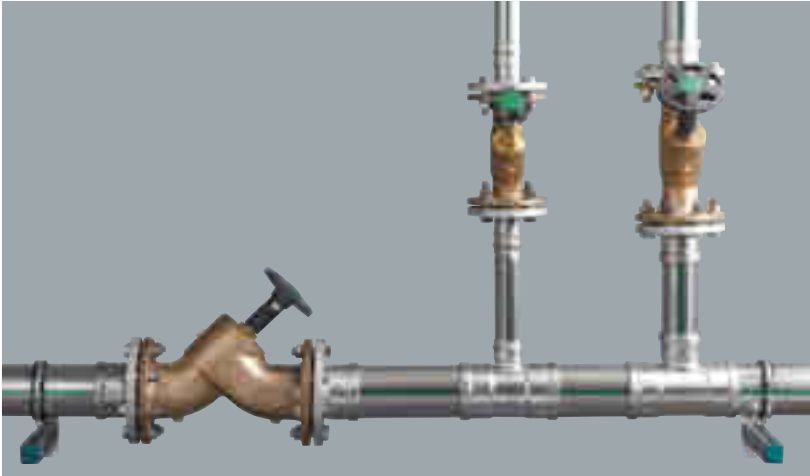

Fig. D – 58

**Sanpress Inox-manifold**

Supply pipe with Easytop XL-slanted seat valve DN 100

Manifold outlets with Easytop XL-slanted seated valves DN 80 and DN 50 with Sanpress Inox XL-flange adapters



Fig. D – 59

**Profipress-manifold**

Manifold outlets 54/64.0 and 76.1 mm with Easytop XL-slanted seated valves with Profipress XL- and Sanpress XL-flange adapters



Fig. D – 60

**Flange adapters**

Sanpress XL

Profipress XL

Sanpress Inox XL

Pressure loss diagram Easytop fittings

Easytop-  
Slanted seat valve  
CRV

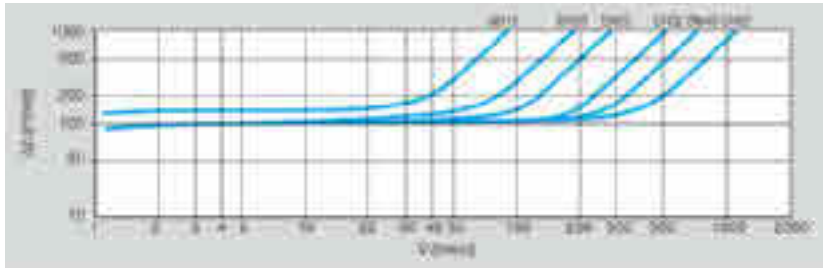

Fig. D – 61

Easytop-  
Backflow preventer

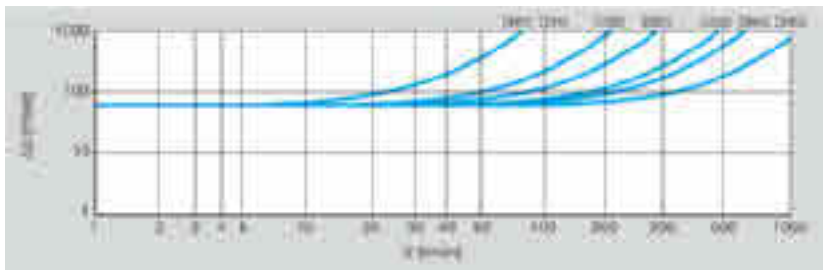

Fig. D – 62

Easytop XL-  
Slanted seat valve  
CRV

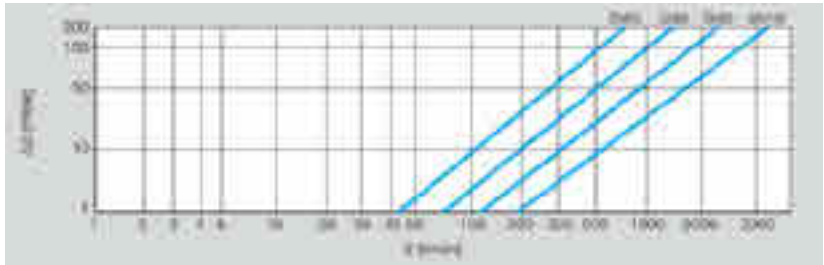

Fig. D – 63

Easytop XL-  
Backflow preventer

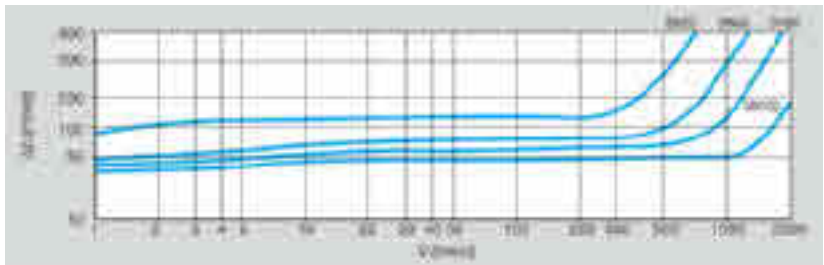

Fig. D – 64

## Easytop sampling valves



### Project description

Quality checks must be stipulated for water for public use. For example, in Germany and in some European countries, drinking water from extraction points in public / commercial buildings must regularly be sampled for chemicals and microbiology. Even for countries, in which there are not yet national regulations for the sampling of drinking water, we recommend the use of the following product solutions.

The two-piece sampling valve is made up of a permanent stainless steel extraction valve and a plug-in, sterilisable and disinfectable actuating unit made of gunmetal which is only used for sampling. Only the one-piece sampling valve is left in the drinking water installation. The actuating unit can be used for taking samples from several extraction valves. The base plate with the discharge pipe can be rotated by 360° and can be fixed at 45° increments to the extraction valve. This makes it possible to attach to almost any position in the system.



The single-component sampling valve is left completely in the installation.

#### Sampling valve - two-piece

	Product name	Size	Model	Art.-No.
	Sampling valve	G $\frac{1}{4}$ G $\frac{3}{8}$	2223.1	708726 708733
	Actuating unit	–	2223.3	708696
	Extraction valve	G $\frac{1}{4}$ G $\frac{3}{8}$	2223.2	708702 708719

Tab. D – 9

#### Sampling valve – one-piece

	Product name	Size	Model	Art.-No.
	Sampling valve	G $\frac{1}{4}$	2223.4	708740
	Adapter	G $\frac{3}{8}$	2223.5	708757

Tab. D – 10

Easytop sampling valve, two-piece

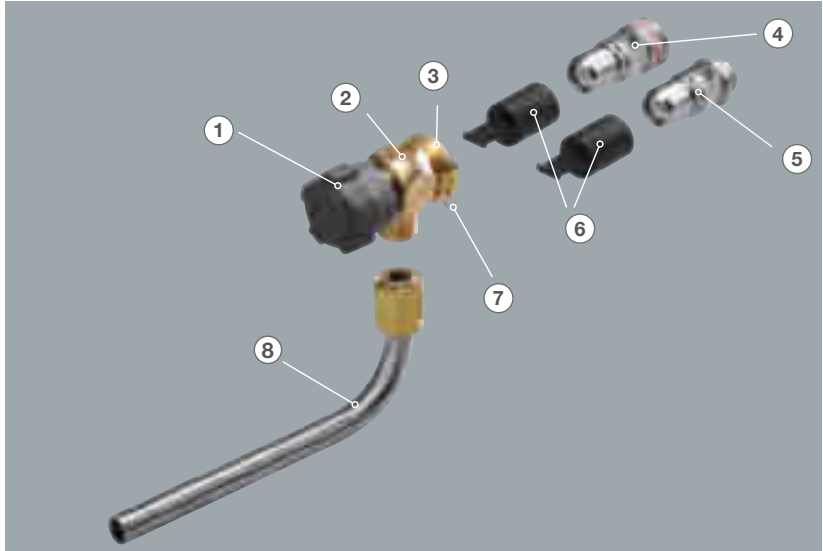

Fig. D – 65

- ① Handwheel – removable
- ② Actuating unit
- ③ Sliding sleeve
- ④ Extraction valve G 1/4 made of stainless steel
- ⑤ Extraction valve G 3/8 made of stainless steel
- ⑥ Protective caps
- ⑦ Retaining clamp
- ⑧ Discharge pipe

Extraction valve

The extraction valve is installed permanently to the defined position of the system. After sampling, the extraction end is protected by a plastic cap. Extraction valves are available in two thread sizes.

Extraction valve - Threaded connections

Feature	G 1/4	G 3/8
Field of use Sizes of fittings [DN]	≤ 50	≥ 65 to ≤ 150
Sealants	EPDM O-ring, chamber-sealing	Teflon sealant, thread-sealing

Tab. D – 11

Extraction valve

Both made of stainless steel G 1/4 with O-ring

G 3/8 with sealant



Fig. D – 66



Fig. D – 67

Actuating unit



Fig. D – 68

For sampling purposes, the actuating unit is inserted into the extraction valve and secured with a retaining clamp and a sliding sleeve. Positioning is possible in 45° increments up to 360°. Because the base plate and the discharge pipe can also be rotated by 360°, the sampling valve can be installed at virtually any position on the system.

Technical data

- Extraction valve of stainless steel, actuating unit made of gunmetal in accordance with DIN 50930-6
- Discharge pipe made of stainless steel, can be flame treated
- Actuating unit suitable for sterilisation in autoclaves
- Operating temperature  $T_{max} = 90^{\circ}C$
- Operating pressure  $p_{max} = 16\text{ bar}$

Features

- Sampling fitting for all kinds of sampling
- Two-piece construction – Extraction valve installed permanently
- Assembly of actuating unit without tools
- Base plate and discharge pipe can be rotated by 360°
- Extraction valve and discharge pipe made of stainless steel
- Sampling by manual actuation
- Alternative operation using air key
- Discharge amount can be regulated exactly with the handwheel
- Tamper-proof
- Protection from water theft



Fig. D – 69



Fig. D – 70

**Actuating unit**

Adjustable by 360° in 45° increments

Discharge pipe can be rotated by 360°

**Easytop sampling complete valve**

Fitted in discharge stoppers of an Easytop XL slanted seat valve with flange connection

In the Easytop slanted seat valve with press connection

### Sampling

Sampling can take place at the prepared positions of the installation, without using tools, by following the following steps

- Remove the protective cap of the extraction valve.
- Insert the actuating unit into the extraction valve and secure in the end position using a retaining clamp and sliding sleeve.
- Apply flame to the discharge pipe.
- Remove water sample by opening the handwheel of the actuating unit.
- After removing the sample, close the handwheel, loosen the sliding sleeve and remove the actuating unit.
- Seal the extraction valve with a plastic cap.
- Disinfect / sterilise the discharge pipe before taking the next sample.

### Easytop sampling valve, one-piece

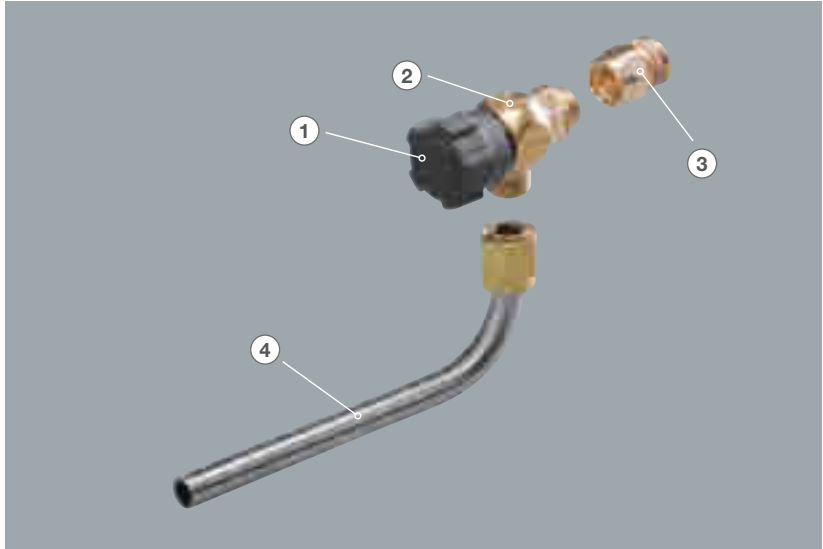

Fig. D – 71

- |                         |                  |
|-------------------------|------------------|
| ① Handwheel – removable | ③ Adapter piece  |
| ② Actuating unit        | ④ Discharge pipe |

The one-piece sampling valve is left in the drinking water installation. Sizes: Internal thread G 1/4 and G 3/8 with Easytop adapter piece.

- Actuating unit made of gunmetal in accordance with DIN 50930-6
- Discharge pipe made of stainless steel, can be flame-treated
- Operating temperature  $T_{\max} = 90^{\circ}\text{C}$
- Operating pressure  $p_{\max} = 16\text{ bar}$

**Features**

- Sampling fitting for all kinds of sampling
- Base plate can be rotated by 360°
- Discharge pipe can be rotated by 360°
- Sampling by manual actuation
- Alternative operation with air key
- Discharge amount can be regulated exactly with the handwheel
- Easytop adapter nipple available for G 3/8



Fig. D – 72



Fig. D – 73

**Easytop sampling -  
Single-component  
sampling valve**

To leave in the installation, fitted in the discharge stopper of an Easytop XL slanted seat valve with flange connection

Fitted with 54 mm



### Easytop-concealed straight seated valve

For shutting off floor or storey units.

#### Technical data

- Suitable for all drinking waters – valve cover made of gunmetal, valve seat stainless steel
- Operating temperature  $T_{\max} = 95\text{ }^{\circ}\text{C}$
- Operating pressure  $p_{\max} = 10\text{ bar}$
- Zero stagnation space in upper part
- Variable installation depths up to 129 mm
- Low noise
- Limescale resistant
- Easy to operate
- One top for all sizes

#### Connection variations

#### Valve construction

#### Connection variations

With

- Female thread acc. EN10226
- Sanpress



Fig. D – 74

#### Valve components



Fig. D – 75

- ① Valve body
- ② Protective sleeve
- ③ Attachment
- ④ Protective cap

### Easytop-concealed free-flow valves

Easytop concealed free-flow valves are used to shut off storeys and floor units. They are suitable for drinking water installations (PWH/PWC) according to TrinkwV and DIN 50930-6. Due to their construction free flow valves have short activation distances. Similar to the ball valve, they can be fully opened or closed with a quarter turn.

For pipes that require insulation, units with building material class B1 insulating sleeves, which fulfil the requirements of EnEV and DIN 4102-4, should be used.

Installation is possible in brickwork (wet construction) and in dry constructions (pre-wall/duct installations).



Fig. D – 76



Fig. D – 77

#### Technical data

- Connections: Press connection 15, 18, 22 mm, thread Rp ½ and Rp ¾
- Operating pressure 10 bar (PN10)
- Operating temperature 90 °C
- Installation possible independent of flow direction

#### Characteristics

- For all types of drinking water according to TrinkwV and DIN 50930-6
- Open/close via a quarter turn
- Valve casing and upper part made of gunmetal according to DIN 50930-6
- Valve upper part without stagnation space – with maintenance-free spindle seal
- Actuation in the skeleton construction phase via protective caps
- Can be combined with the equipment sets models 2236 and 2236.10
- Shut-off component exchangeable – one kind for all kinds of valves
- Conforms to DVGW-AB W270, with KTW-recommendation

#### Insulation

#### Assembly

#### Easytop-concealed free flow valve

Made of gunmetal, with press connection

With threaded connection Rp

**Installation dimensions**

Installation depth

≥ 43 (A)

≤ 130 mm (B)

**Fastening set**

»Front«

Model 2235.90



Fig. D – 78



Fig. D – 79

**Valve components**

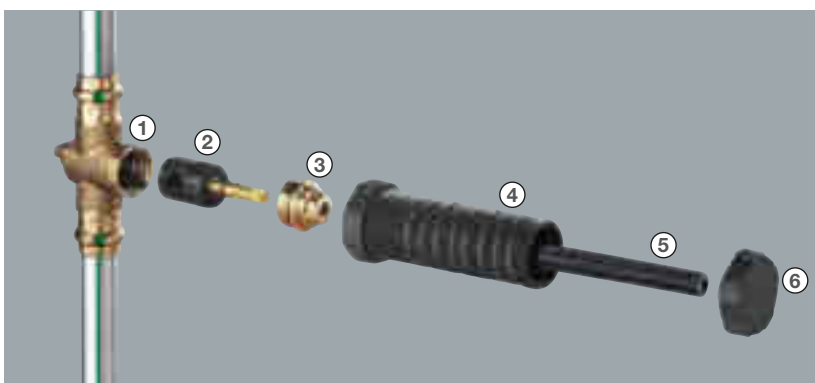

Fig. D – 80

- ① Valve body
- ② Shut-off unit
- ③ Valve upper part

- ④ Protective sleeve
- ⑤ Attachment
- ⑥ On-site protective cap

### Fastening/Seal

The system offers various solutions and mounting sets for securing the valve.

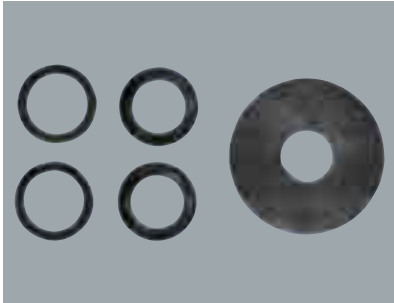

Fig. D – 81



Fig. D – 82

#### Frontal assembly set

For frontal, sandwich assembly

### Mounting by placing it through a wall

Both nuts and sealing panels clamp the protective sleeve securely in the wall (plasterboard).

The sealing action of the wall is reinforced by a self-adhesive sealing flange on the front side of the wall. The valve is permanently accessible via the protective cap.

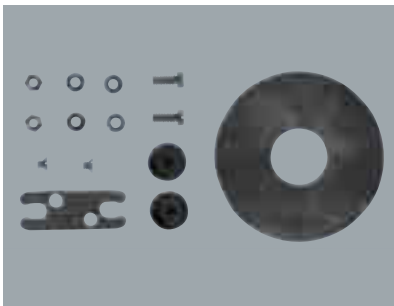

Fig. D – 83



Fig. D – 84

#### Rear assembly set

Conventional in stand construction

### Mounting using the assembly set

The noise decoupled mounting plate is connected to the valve body and a mounting rail (Profilrail).

Sealing through the wall is via a self-adhesive sealing flange on the front side of the wall. The valve is permanently accessible via the protective cap.

**Fitting sets**

For Easytop concealed straight seated valves



*Fig. D – 85*



*Fig. D – 86*

**Insulating sleeve**

The self-securing insulating sleeve made of EPP-insulating material fulfils the requirements of the EnEV regarding the reduction of heat loss.

One version is suitable for every type of connection.



*Fig. D – 87*

## Easytop-ball valves

With press connectors for the following systems

- Sanpress Inox
- Sanpress
- Profipress

### Characteristics

- Suitable for all types of drinking water – valve cover made of gunmetal
- With press connection, female thread or male thread
- Operating temperature  $T_{\max} = 110^{\circ}\text{C}$
- Operating pressure  $p_{\max} = 16\text{ bar}$
- Media identification mark on the handle is exchangeable
- Further application: Heating, compressed air, rainwater and industrial systems etc.
- Insulating sleeve compliant with EnEV as accessory



Fig. D – 88

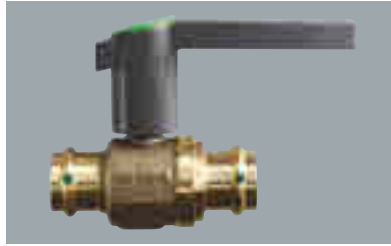

Fig. D – 89

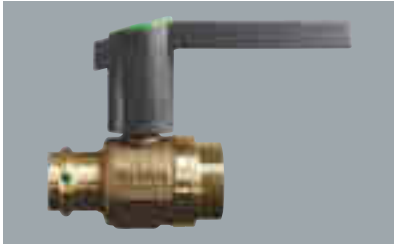

Fig. D – 90



Fig. D – 91



Fig. D – 92



Fig. D – 93

**Maximum physically approved value**

**Press connection**

**Press-/Threaded connection**

**Threaded connection acc. ISO 228-1**

**Threaded connection acc. EN 10226-1**

**Pump ball valve**

## Thermostatic circulation regulating valve S / E

### Product description

The Easytop circulation regulating valve S / E supports the provision of constant water temperatures at each extraction point in hot water circulating pipes. Through automatic opening and closing, it regulates the flow rate in dependence with the water temperature in the circulation pipe.

It is quick and safe to fit to the installation in all Viega pipe systems with press connections with 15, 18 and 22 mm or with screws in G 3/4 and G 1 (flat-sealing). It can be used in parallel and internal circulation lines.

### Easytop CRV

Structure /  
Components

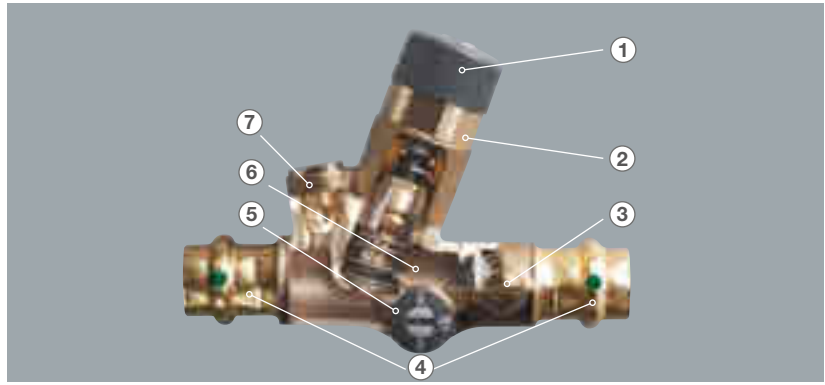

Fig. D – 94

- |                                   |   |
|-----------------------------------|---|
| ① Temperature setting             | ⑤ Modes of operation: Riser pipe, building storey, thermal disinfection |
| ② Control unit                    | ⑥ Valve casing made of gunmetal   |
| ③ Ball valve                      | ⑦ Stopper for discharge valve   |
| ④ Press connection with SC-Contur |   |

### Functional principle

The control unit of the Easytop circulation regulating valve (CRV) is equipped with an expansion material element, which reacts to temperature changes of the warm water in the circulation loop. If the pre-set target valve deviates from the actual valve, the flow rate is changed using the valve lift, thus regulating the water temperature.

- The valve opens if the target value is fallen below
- The valve closes if the target value is exceeded

The hydraulic/thermal compensation has occurred when the target and actual value conform.

### Thermal disinfection

The circuits are individually disinfected one after the other in systems with several circulation loops. You should follow the steps below

- Ensure that the temperature in the hot water tank is at least 70 °C.
- Close the ball valves of all CRV.
- To flush the first circulation loop, open the ball valve of the CRV.
- Set the mode of operation to »t. D.« on the circulation regulating valve.
- One after the other, completely open all discharge fittings and allow to flush with water for at least 3 minutes at a discharge temperature of 70 °C.
- Set the CRV back to the operating position and close the ball valve.
- Do the same with the other circulation loops one after the other.

### Assembly

#### Place and site of installation

It is possible to install in either a riser pipe or on a building storey. Installation on a building storey always occurs in connection with a static CRV in the riser pipe.

CRVs must be installed between the outlet of the hot water tank and the inlet of the circulation line of the hot water tank.

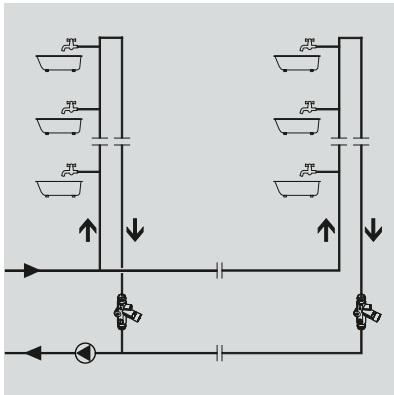

Fig. D – 95

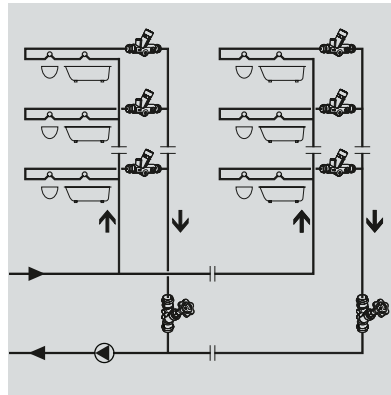

Fig. D – 96

The actuator should preferably be installed in a vertical and horizontal location. Above-head assembly should be avoided because unfavourable operating conditions (e.g. contaminated water) can reduce the life span.

#### Uses

Thermostatically in the riser pipe with switch position II

On a building storey with switch position I in connection with a static circulation regulating valve in the riser pipe



**Pressure loss**

- Mode of operation I and II
- Thermal disinfection (t.D.)

**Setting of the flow rate regulation**

- On the building storey – Switch position »I« with minimum flow rate of 0.042 m<sup>3</sup>/h
- Riser pipe – Switch position »II« with minimum flow rate of 0.060 m<sup>3</sup>/h
- t. D. – Thermal disinfection flow rate according to table below

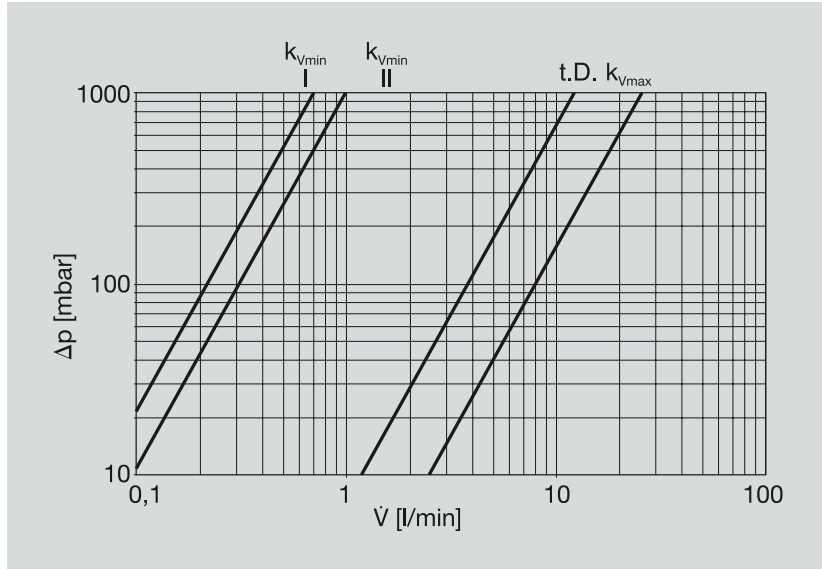

Fig. D – 97

**Circulation regulating valve settings – Flow regulation**

	Temperature setting							kV (Δp 1000 mbar)	
	[°C]							[m <sup>3</sup> /h]	
	65	60	57	55	50	45	40	I	II
Flow temperature	65.0	60.0	57.5	55.0	50.0	45.0	40.0	0.042	0.060
	60.0	57.5	55.0	52.5	47.5	42.5	37.5	0.258	0.276
	57.5	55.0	52.5	50.0	45.0	40.0	35.0	0.407	0.425
	55.0	52.5	50.0	47.5	42.5	37.5	32.5	0.618	0.636
	52.5	50.0	47.5	45.0	40.0	35.0	30.0	0.803	0.821
	50.0	47.5	45.0	42.5	37.5	32.5	27.5	1.056	1.074
	47.5	45.0	42.5	40.0	35.0	30.0	25.0	1.178	1.196
	45.0	42.5	40.0	37.5	32.5	27.5	22.5	1.296	1.314
	42.5	40.0	37.5	35.0	30.0	25.0	20.0	1.325	1.400
	40.0	37.5	35.0	32.5	27.5	22.5	-	1.479	1.497
	37.5	35.0	32.5	30.0	25.0	20.0	-	1.488	1.506
	35.0	32.5	30.0	27.5	22.5	-	-	1.506	1.524
								1.542	1.560
								<b>t. D.</b>	
								<b>Thermal disinfection 70 °C</b>	
								0.72	

Tab. D – 12

### Actuator - Connection to the building control system

In connection with a building control system (on-site), the actuator set Model 1013.9 should be used.

#### Functional principle

The actuator is equipped with an electrically heated expansion material element, whose movements are transferred via a valve lifter to the valve - the higher the heating energy (operating voltage), the wider open the valve.

When activating the operating voltage - after the delay has elapsed - the valve opens against the pressure of a pressure spring. The closing force of the pressure spring is coordinated with the closing force of conventional valves and holds the valve closed in a de-energised state.

After deactivating the operating voltage, the valve closes after the pause has elapsed.

**Note:** The actuator is supplied in a “first open function”, this means: Initially, it is “open in a de-energised state”.

This permits operation during building phases, even when the electrical wiring has not yet been completed. The “first open function” is automatically switched off as soon as the operating voltage remains in contact for more than 6 minutes.

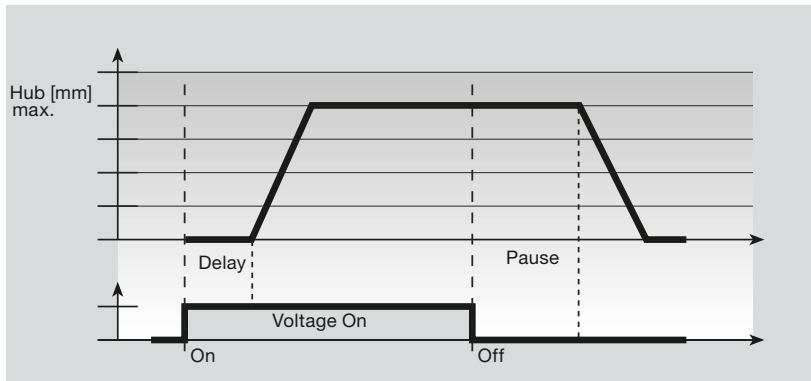

Fig. D – 98

#### Actuator

Action in normal operation

Closed without power

**Retrofitting of an actuator set**

The manually adjusted valve top of the circulation regulating valve can be replaced with an electrical actuator (model 1013.9).

The regulating electronics / building control system should be provided on-site.

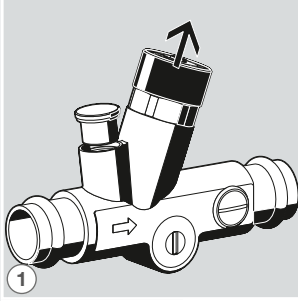

1

Fig. D – 99

Remove the valve top of circulation regulating valve

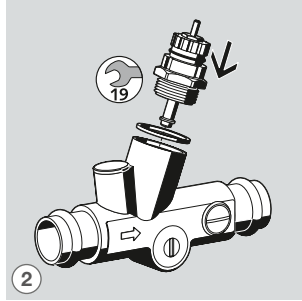

2

Fig. D – 100

Screw in the valve insert

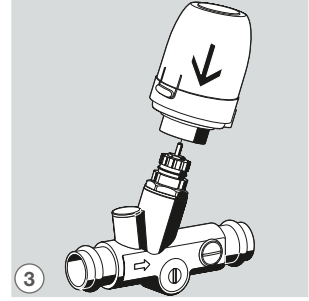

3

Fig. D – 101

Fit actuator

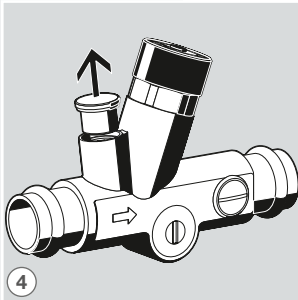

4

Fig. D – 102

Remove the stopper

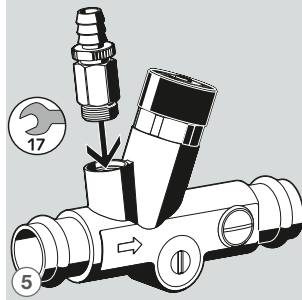

5

Fig. D – 103

Screw in the discharge valve

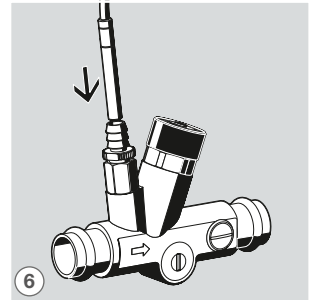

6

Fig. D – 104

Insert temperature sensor  
Alternative: Analogue thermometer

**Wiring**

Actuator set

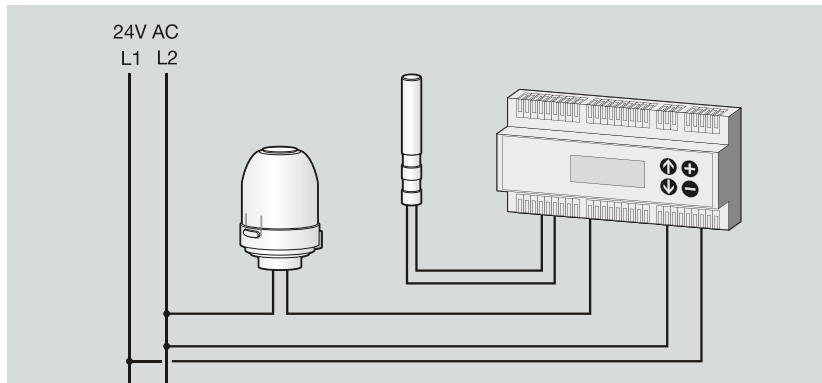

Fig. D – 105

## Electrical installation

### Lines

For the installation, we recommend pipework in accordance with the table below.

#### Types of pipe

	Description	Diameters
<b>Bell wire</b>	Y (R)	0.8mm <sup>2</sup>
<b>Non-metallic sheathed wire</b>	NYM	1.5mm <sup>2</sup>

Tab. D – 13

Calculation for the maximum pipe length (copper pipe) with 24 V nominal voltage as per formula:

$$L = K \cdot A / n$$

With:

**A** Cross-section of the pipe in mm<sup>2</sup>

**n** Number of actuators

**K** Constant (269 m / mm<sup>2</sup>)

**L** Pipework length in m

### Transformer (24 V)

Safety transformers as per DIN EN 60335 must be used. The output is dependent on the switching capacity of the actuator and is approximately:

$$P_{\text{Trafo}} = 6W \cdot n$$

With:

**n** Number of actuators

## Technical data

### Thermostatic regulating valve

<b>Operating pressure max</b>	10 bar
<b>Setting range</b>	40 to 65 °C
<b>Factory setting</b>	57 °C

Tab. D – 14

### Temperature sensor

<b>Resistance</b>	3.85 Ω/°C
<b>Connecting cable</b>	TF45
<b>Measuring range</b>	- 20 to + 105 °C
<b>Measuring element</b>	1 x Pt1000 / dual conductor/ Cl. B
<b>Protective pipe material</b>	1.4571
<b>Protective pipe diameter</b>	6.0 mm
<b>Protective pipe length</b>	50.0 mm
<b>Connection / length of pipe</b>	2 x 0.34 mm <sup>2</sup> PVC, grey / 2.5 m
<b>Protection class</b>	Min. IP 54
<b>Time constant</b>	Min. 20 s
<b>Permitted drop</b>	With and without packaging 1 m

Tab. D – 15

**Actuator**

<b>Ausführung</b>	Closed without power / open without power
<b>Voltage</b>	24 V AC / DC + 20% ... - 10% 0 to 60 Hz
<b>Starting current max.</b>	250 mA for max. 2 min
<b>Operating current</b>	75 mA
<b>Operating efficiency</b>	1.8 W
<b>Closing and opening times</b>	Approx. 3 min
<b>Displacement</b>	4.0 mm
<b>Actuating power</b>	100 N ± 5%
<b>Medium temperature</b>	0 to 100 °C <sup>1</sup>
<b>Storage temperature</b>	- 25 to + 60 °C
<b>Ambient temperature</b>	0 to +60 °C
<b>Protection class</b>	IP 542
<b>CE conformity</b>	In accordance with EN 60730
<b>Casing / Casing colour</b>	Polyamide / grey
<b>Weight</b>	100 g with 1 m connecting cable
<b>Connecting pipe / pipe length</b>	2 x 0.75 mm <sup>2</sup> PVC, grey / 11 m
<b>Excess voltage resistance</b>	In accordance with EN 60730-1

Tab. D – 16

<sup>1</sup> Can also be higher, depending on the adapter

<sup>2</sup> In all installation locations

**Static circulation regulating valve**
**Product description**

The static Easytop circulation regulating valve is used for the hydraulic calibration of riser pipes and in installations with circulation loops, if thermostatic circulation regulating valves are installed on a building level.



Fig. D – 106

The flow quantities are taken from pressure loss diagrams and manually adjusted to a scale. The found setting position (maximum flow quantity) can be mechanically fixed and can be reproduced at any time, even if the valve has been actuated in the meantime.

**Technical data**

- Operating pressure  $p_{\max} = 10$  bar
- Setting range 0 – 6.9

**Note**

The flow direction must be taken into consideration during installation (arrow on the CRV).

A straight length of pipe with a minimum length of 3 x  $d_a$  must be fitted in front of the fitting.

Pressure loss diagrams

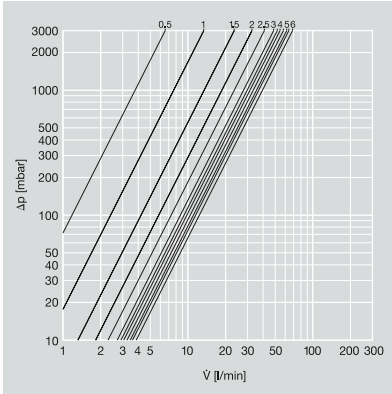

Fig. D – 107

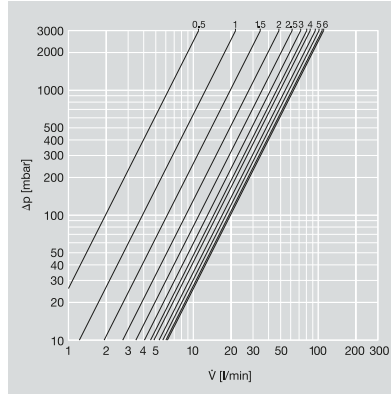

Fig. D – 108

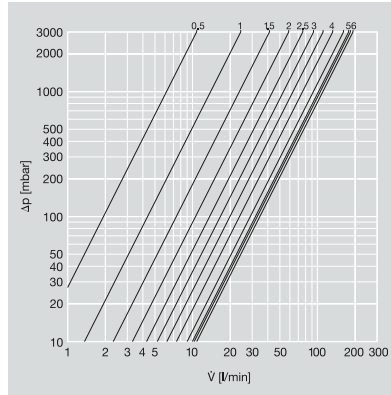

Fig. D – 109

DN15

DN20

DN25

## Smartloop-Inliner circulation line

### Intended use

The system is suitable for use as an internal circulation line in drinking water installations, especially in hot water riser pipes from 28 mm, together with the Viega press connector systems.

To lay a drinking water installation with Smartloop-Inliner technology, we recommend using the Viega Viptool planning software.

Installation is only permitted by trained specialists exclusively using Viega components. Any applications differing from those described here must be agreed with Viega Service Center.

### System Description

The system consists of the components

- Connecting kit, with end connector and Smartloop-pipe connections
- Smartloop-pipe, flexible.

#### Smartloop-inliner

Connecting kit



Fig. D – 110



Fig. D – 111

#### Smartloop-pipe

Hygienically packed through to assembly



Fig. D – 112

The circulation of hot water in the pipe is achieved by permanently channeling water back into the water heating system from the last T-piece of the riser pipe. This ensures that sufficient hot water is available at hygienically flawless temperatures at every floor outlet.

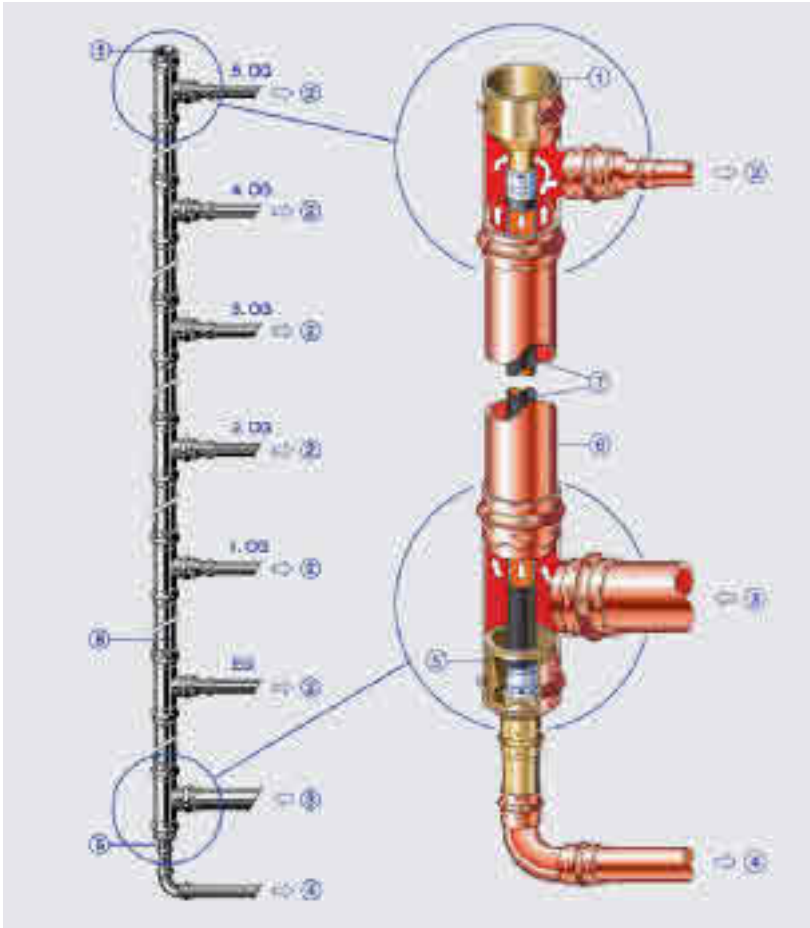

Fig. D – 113

- |                                 |                             |
|---------------------------------|-----------------------------|
| ① End closing piece             | ⑤ Connection piece          |
| ② Storey connection pipe – warm | ⑥ Warm water riser pipe     |
| ③ Warm water distribution pipe  | ⑦ Internal circulation pipe |
| ④ Circulation collector pipe    |                             |

**Circulation Pipe**  
Smartloop-Inliner



### Temperature Graduation

In comparison to conventional circulation, the temperature in the riser pipe area does not drop continually in the direction of flow with Smartloop-Inliner circulation.

The lowest temperature in the riser pipe is not at the crossover between the riser pipe and circulation collector pipe ②. Instead, it is in the end connection near the direction change in the internal circulation ①. With large-scale systems with several lines, this leads to an increase of temperature in the circulation collector pipe. As a result, the temperature of the back-flow water is higher than with conventional circulation systems, which, in turn, has advantages in terms of energy.

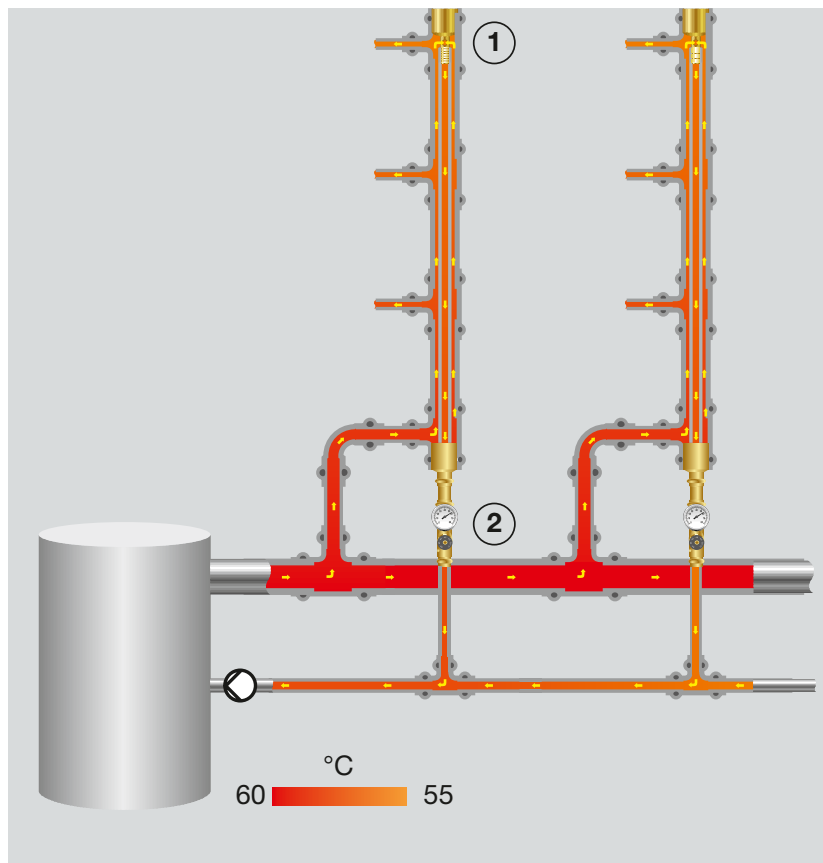

Fig. D – 114

- ① Hot water floor outlet
- ② Hot water distribution pipe

### Advantages

- 20 to 30 % less heat distribution losses
- Guarantee of drinking water quality as a result of temperature maintenance and circulation
- Lower heat emissions in the duct supports temperature maintenance in cold water
- Approx. 20 % lower costs for core drillings, fire protection, pipe insulation and fastenings
- Lower assembly costs as there is no need for a separately laid circulation pipe system
- More living space due to smaller installation ducts
- Flexible Smartloop pipe permits parallel offset in the riser pipe



Fig. D – 115

Offset riser pipe

Components

**Connection set**

Model 2276.1



- ① End closure plug
- ② Adaptor
- ③ Connecting piece
- ④ Press sleeve

Fig. D – 116

**Tension coupling**

Model 2276.9



- ① Support sleeve
- ② Jack head

Fig. D – 117

**Repair coupling**

Model 2276.8



- ① Repair coupling
- ② Press sleeve

Fig. D – 118

**Smartloop-pipe**

Model 2007.3



Fig. D – 119

## Assembly

The components and tools required to assemble a Smartloop-Inliner in a Sanpress, Sanpress Inox or Profipress riser pipe are shown on the side before previous page. The press connection for the Smartloop-pipe can be carried out using manual pressing tools (Model 2782) or the pressing pliers (Model 2799.7) and a suitable press machine – we recommend using the Viega press machines PT2, PT3H, PT3-AH, PT3-EH or Pressgun 4E and 4B. Pressgun 5.

### Assembly with Parallel Offset

The flexible Smartloop-pipe also enables assembly in offset riser pipes. Even wall projections and ducts that are not aligned with one another are no obstacle for professional assembly.

The Materialprüfungsamt NRW has inspected and examined the assembly in the case of parallel offsetting of the riser pipe for the necessary requirements.

Vertical offsetting of the riser pipe in a position does not affect the function or the assembly of the Inliner. Any installation situations differing from those shown should be agreed with Viega Service Center.

To incorporate the Smartloop-pipe, we recommend using the tension coupling or, for more pronounced offsetting, the adapted assembly method.

## Preparations

### Maximum offset – Material suggestion

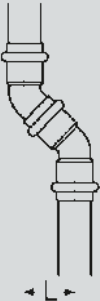
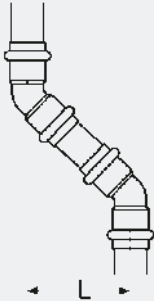
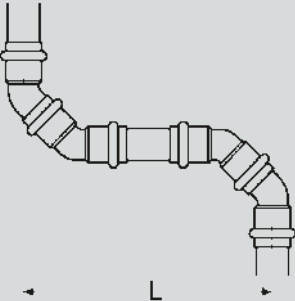
Offset	Minimal	45°	90°
			
<b>Diversion</b> L [mm]	≥ 40 – 45	≥ 45 – 500	≥ 150 – 500
<b>Components required</b>	1 bend 45° 1 bend 45°, with insertion ends	2 bend 45°	2 bend 45° 2 bend 45°, with insertion ends

Tab. D – 17

**Assembly with slight or no offsetting**

Assembly of the riser pipe with subsequent incorporation of the Smartloop-pipe.

Fig. D – 120  
Fig. D – 121  
Fig. D – 122

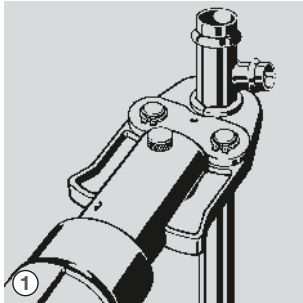

- Build the riser pipe and press on a Tee above and below.
- Create floor outlets size 22mm, if necessary reduce.

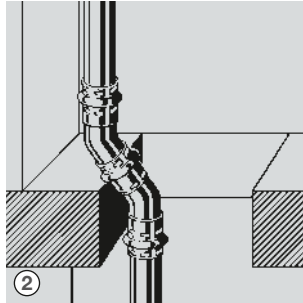

In the case of slight offsetting, combine two 45° arches: the upper with the shank, the lower with two press ends.

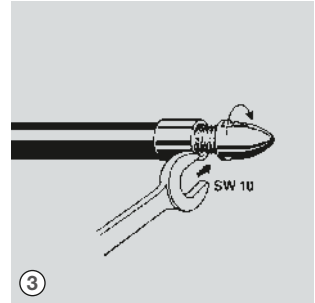

The tension coupling (Model 2276.9) is helpful for incorporation of the Smartloop-pipe.

Fig. D – 123  
Fig. D – 124  
Fig. D – 125

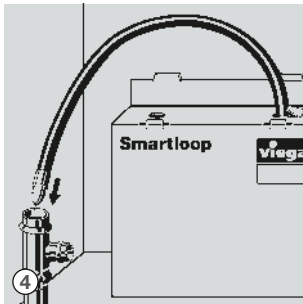

Introduce the Smartloop-pipe from above into the hot water riser pipe until the pipe protrudes at the lower end of the riser pipe by about 30 cm.

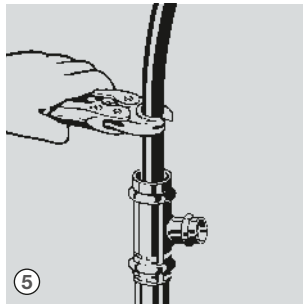

Shorten the Smartloop-pipe appropriately.

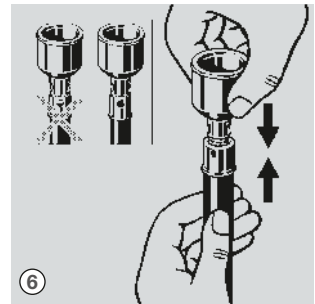

- Push the press sleeve onto the upper pipe end.
- Push the end connection into the pipe and check the insertion depth using the inspection panel.

Fig. D – 126  
Fig. D – 127  
Fig. D – 128

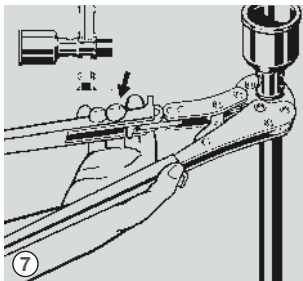

- Apply the manual press pliers at a right-angle.
- When pressing, compress until the pliers can be reopened. Trim the Smartloop-pipe to fit.

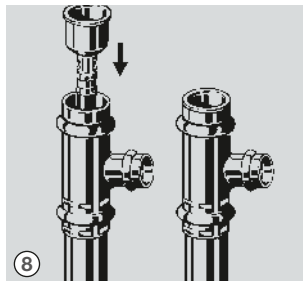

Position the end connection in the upper Tee of the hot water riser pipe.

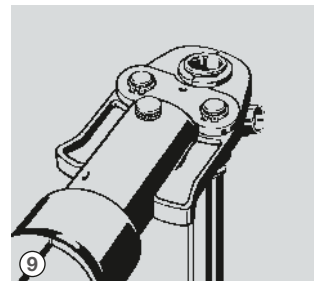

Press the connection with a suitable pressing tool.

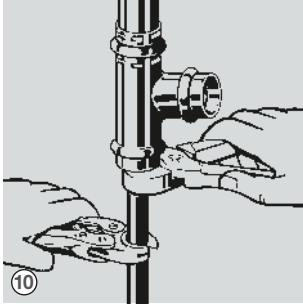

- Tighten the Smartloop-pipe on the lower end using assembly pliers and cut to length 40mm below the Tee at a right-angle.
- Tighten the Smartloop-pipe.

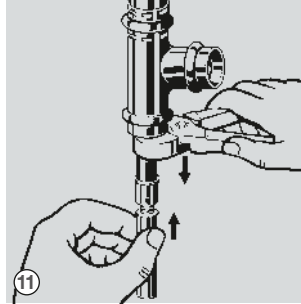

- Push the press sleeve onto the lower Smartloop-pipe end.
- Push the crossover part of the connection into the Smartloop-pipe and check the insertion depth using the inspection panel.

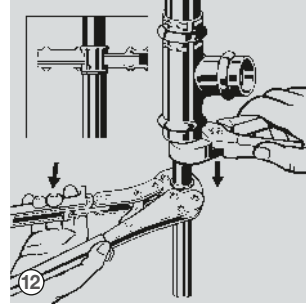

- Apply manual pressing pliers at a right-angle and compress until the pliers can be reopened.

Fig. D – 129  
Fig. D – 130  
Fig. D – 131

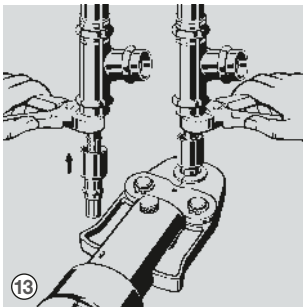

- Push the connection to the end of the crossover part and press.

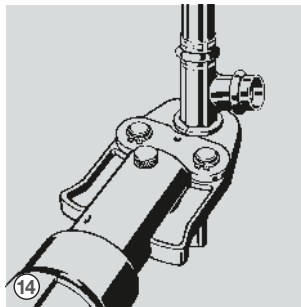

- Remove assembly pliers.
- Push the connection to the end of the lower Tee of the hot water riser pipe and press.

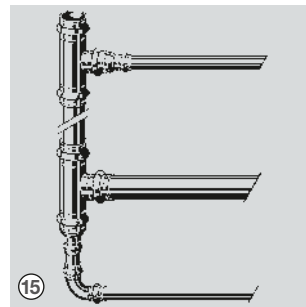

- Create a connection from the hot water riser pipe and the circulation pipe to the relevant cellar distribution and collector pipes.
- Check the entire piping system for leaks in accordance with ZVSHK datasheet.

Fig. D – 132  
Fig. D – 133  
Fig. D – 134

### Repair coupling

In the case of a damaged riser pipe or the extension of the installation, Smartloop-pipe is repaired using the repair coupling model 2276.8 and the riser pipe using the sliding coupling models 2215.4 and 2215.5.

Fig. D – 135  
Fig. D – 136  
Fig. D – 137

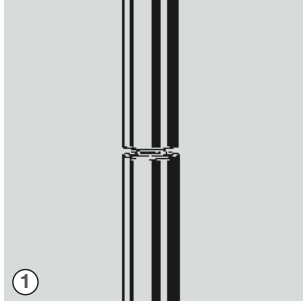

① Cut through the installation pipe and the Smartloop-pipe completely.

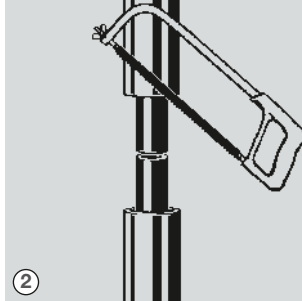

② Using a fine toothed saw or pipe cutter, cut the piece of pipe – the length of the sliding coupling – out of the riser pipe.

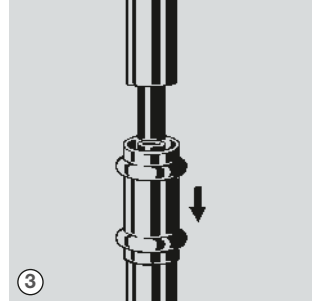

③ Push the sliding sleeve model 2215.5 onto the lower pipe.

Fig. D – 138  
Fig. D – 139  
Fig. D – 140

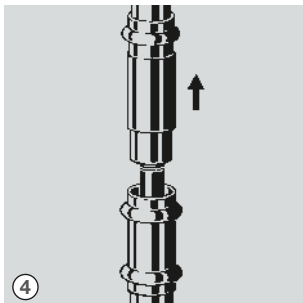

④ Push the sliding sleeve with the insertion part model 2215.4 onto the upper pipe.



⑤ Place the repair coupling model 2276.9 onto the Smartloop-pipe.

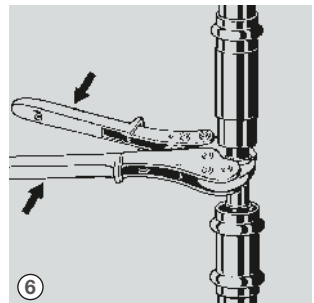

– Press the repair coupling  
– Apply manual pressing pliers at a right-angle and compress until the pliers can be reopened.

Fig. D – 141  
Fig. D – 142  
Fig. D – 143

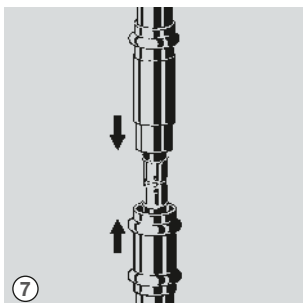

⑦ Join the sliding sleeves together.

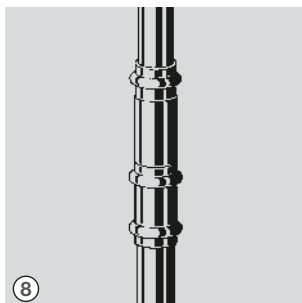

⑧ Place the sliding sleeves in such a position that the minimum insertion depth in the press sleeve is ensured.

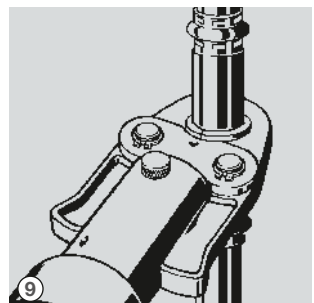

⑨ Press the press connection with a suitable press machine.

## Sealing elements – overview

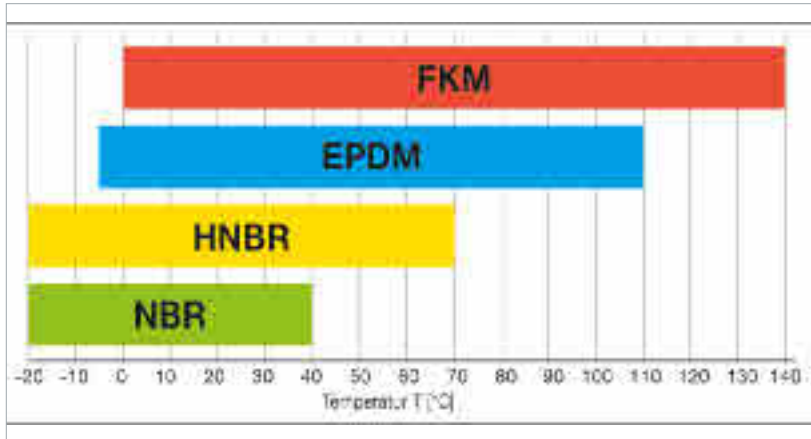

Fig. D – 144

In general, in Viega piping systems 4 elastomers are used. Each has an individual performance profile, depending on the application.

NBR is only used for cold water, such as cooling water or earth laid service pipes. Whereas a HNBR seal possesses a high elasticity at low temperatures, such as exposed gas installations, an EPDM quality seal from Viega provides an excellent performance for the majority of water and heating applications, even for those above 70 °C.

Especially metallic piping systems are often used in the renovation and extension of commercial and industrial units, where high operating temperatures are to be found. For this reason, press connectors with EPDM seals are regarded as being universally applicable for heating and drinking water systems.

EPDM (ethylene propylene diene rubber) is a synthetically made and peroxide-cured all-purpose rubber. It is highly resistant to ageing, ozone, sunlight, weathering and environmental influences, alkalines, alkaline solutions and chemicals. For these reasons the user can expect a long-term secure connection, when the conditions of use are observed.

Finally, FKM sealing elements fulfill the highest requirements in terms of operating temperature, e.g. in solar thermal systems with heat pipe collectors.

Viega press connectors for drinking water supply systems are factory-fitted with black EPDM sealing elements. On account of its high resistance to hot water and steam, EPDM is also used for seals and moulded parts in heating engineering, in fittings and domestic appliances (washing machines, pumps, dishwashers, etc.) at operating temperatures of up to  $T_{max} = 110^{\circ}\text{C}$ .

**Elastomer seals**

Used in metallic piping systems



## Mixed installations

### Installation in the flow direction

System	Before galvanized iron materials	After galvanized iron materials
Sanpress Inox	✓	✓
Sanpress	✓	✓
Profipress	–	✓

Tab. D – 18

### Insulated pipe joint

In the event of higher drinking water hardness, Sanpress insulated pipe joints should be installed in order to avoid contact corrosion and crustification.

#### Sanpress- insulated pipe joint



Fig. D – 145

- ① Gumetal threaded gland with Rp female thread to EN 10226
- ② EPDM flat seal, not electrically conductive
- ③ Sanpress/Profipress bronze press-in gland with SC-Contur
- ④ Isolating ring for electrical isolation
- ⑤ Cap nut

**Boiler connection**

If using insulated pipe joints to connect the boiler, the boiler itself must not be incorporated into the potential equalisation.

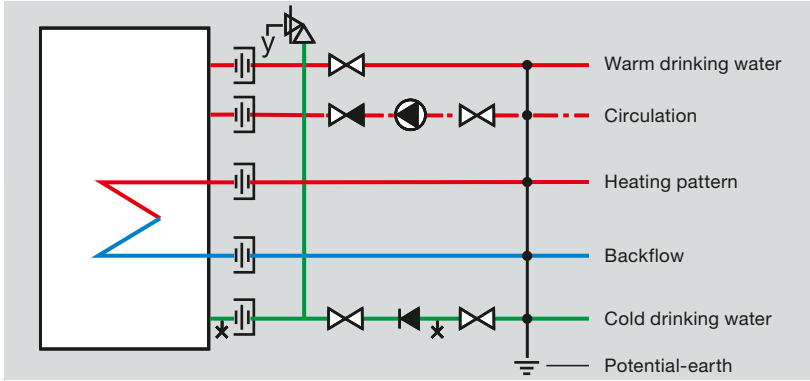

Fig. D – 146

**Potential equalisation**  
At the boiler connection

**Potential equalisation**

If sections of the pipe system are modernised, once work is complete, potential equalisation must be restored. If you are using insulated pipe joints, you must use an NYM-J 1 x 6 mm<sup>2</sup> earth conductor to bypass the pipe section.

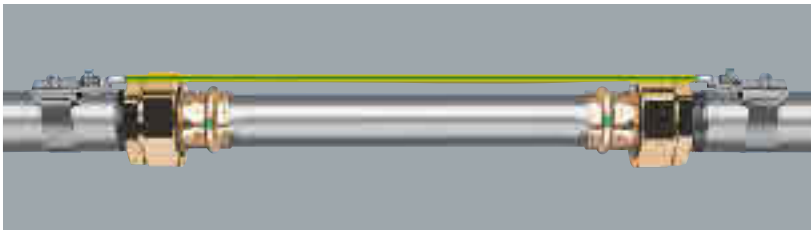

Fig. D – 147

**Insulated pipe joint**

The section between the insulated joints should not be incorporated into the potential equalisation.  
The national regulations should be observed.

## Assembly

Pipe sizes and fastening intervals of pipes [m]

	Sizes [mm]	Sanpress	Sanpress Inox	Profipress	Fastening interval [m]
Standard	12	✓	–	✓	1.25
	15	✓	✓	✓	1.25
	18	✓	✓	✓	1.50
	22	✓	✓	✓	2.00
	28	✓	✓	✓	2.25
	35	✓	✓	✓	2.75
	42	✓	✓	✓	3.00
	54	✓	✓	✓	3.50
XL	64,0	–	✓	✓	4.00
	76,1	✓	✓	✓	4.25
	88,9	✓	✓	✓	4.75
	108,0	✓	✓	✓	5.00

Tab. D – 19

## Storage and transportation

### Stainless steel pipes

Sanpress stainless steel pipes are thin-walled welded pipes made from material 1.4401 or 1.4521 compliant with EN 10088.

To prevent damage impairing hygienic characteristics, the following information must be taken into account when transporting and storing pipes

- Do not remove protective foils and protective caps until immediately before use.
- Do not store the pipes on hard floors without protection.
- Do not stick protective foils or similar to pipes.
- Do not pull pipes over loading sills.
- Only use a stainless steel cleaning agent to clean the surfaces of pipes.

### Copper pipes

Copper pipes meet the requirements of EN 1057. The manufacturer's information must be observed in regards to storage and transportation.

## Pipes

### Cutting

Copper pipes and stainless steel pipes can be cut to length with pipe cutters, fine-toothed metal saws or motorised saws.

When cutting pipes to length, note

- Do not use angle grinders or flame cutters.
- Only use separating tools and separating agents compatible with the pipe material in question.
- You must use a suitable saw when cutting soft copper pipes (ring material) and factory-insulated copper pipes to length.
- Following separation you must de-burr the pipes internally and externally.

## Bending

Suitable machines must be used to bend Sanpress stainless steel pipes or copper pipes. Refer to the production information provided by the pipe manufacturer for bending radii. Generally valid for Sanpress-stainless steel and copper pipes  $R \geq 3.5 \times d$ .

- Expansion bends must be straight and at least 50 mm in length in order to ensure that press connector sleeves can be connected correctly.
- Bending tension between bend and press connector must be avoided.
- Check compatibility with pipe material before using bending sprays.
- Stainless steel pipes may only be bent when cold. Heat treatment can cause corrosion and is not permissible.
- Observe manufacturer specifications when working with copper pipes.

## Routing and fastening

Fasten pipes using commercially available pipe clamps with chloride-free protective inlay. General fastening rules apply

- Only use plugs with building inspection approval.
- Do not use pipes that have been previously installed as a mount for other pipes and components.
- Pipe hooks are not permissible.

To ensure that the pipe system functions correctly, observe the fastening intervals specified in *Tab. D-11*.

## Fastening method

Pipes can be fastened so that they are rigid or flexible.

Rigid fastening points create a fixed connection between the pipe and the component, whilst flexible points facilitate axial expansion movement.

Rigid points must be arranged in such a way

- as to exclude torsional stress due to elongation insofar as is possible
- so that straight sections of pipe only have one rigid point.

Flexible points must be located a sufficient distance away from connectors. The anticipated elongation must be taken into account.



Fig. D – 148

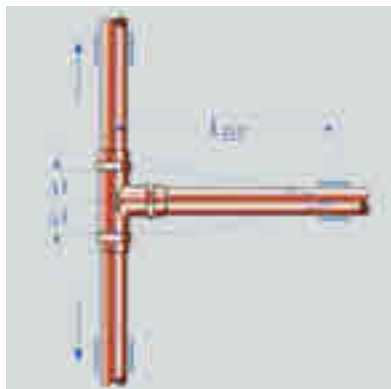

Fig. D – 149

### Rigid points

### Flexible points

#### Rigid point

Observe distance to connector

#### Flexible point

Take direction of expansion into account

**General instructions**

**Concealed installation of pipes that become hot**

Expansion movement causes cracking noises and flow noise. Therefore, insulation must be used to isolate the pipe system completely from the building structure.

When insulating pipes, note

- Only use suitable insulating materials.
- Do not flush-mount pipes.
- Take particular care when insulating tees and bends.

**Insulated pipe joint**

**Threaded joints**

Only commercially available hemp-free and chloride-free sealants may be used to seal threads on adapters connecting to Viega press systems. We do not recommend the use of Teflon tape, as experience has shown that it presses out of the connector when the latter is screwed in.

Pipe connectors have conical female threads (e.g. R 3/4) and cylindrical male threads (e.g. Rp 3/4).

During mounting, you should connect the threaded joint first and then the press connector.

**Flanged connections**

Flanged connections in sizes between 15.0 and 108.0mm may be used in metallic press systems.

Accessories available

- Screw sets in galvanised or stainless steel
- Seals made from EPDM or asbestos-free sealant should be selected depending on the area of application

During mounting, you should connect the flanged connection first and then the press connector.

Fig. D – 150  
Fig. D – 151



**Sanpress Inox**  
Fixed Flange adapter  
Stainless steel 1.4401 (press sleeve)  
15 – 54 mm                      Model 2359  
64.0 – 108.0mm                Model 2359XL



**Sanpress**  
Flexible Flange adapter  
steel, black powder-coated,  
with gunmetal press connector  
28 – 54 mm                      Model 2259.5  
64 mm (copper)                Model 2459.5XL  
76.1 – 108.0mm                Model 2259.5XL

## Making the press connection

### Pipe sizes 12 – 54 mm

The press connection provides an easy and reliable means of connecting stainless steel and copper pipes.

To make this connection, you will need

- Pipe cutters or a fine-toothed steel saw
- De-burrer and coloured pen to mark the insertion depth
- Viega press tool with press jaw suitable for pipe diameter



① Cut the pipe to length at a right angle.

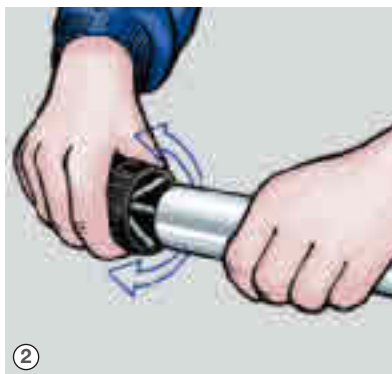

② De-burr pipe internally and externally.



③ Check that the sealing element is seated correctly.

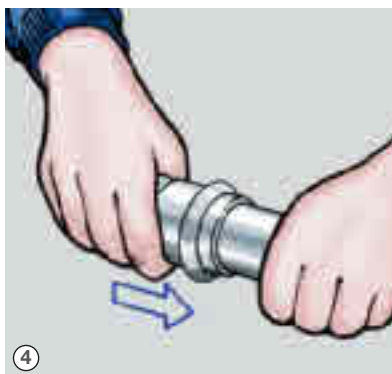

④ Slide the press connector onto the pipe as far as the stop.

Use pipe cutters or a fine-toothed steel saw.  
Cutting with an angle grinder will temper the material. Risk of corrosion!  
Do not use any oils or greases!

For  
Sanpress Inox  
Sanpress  
Profipress

Required tools

How to proceed

Fig. D – 152  
Fig. D – 153

Fig. D – 154  
Fig. D – 155

Fig. D – 156  
Fig. D – 157



⑤ Mark the insertion depth.

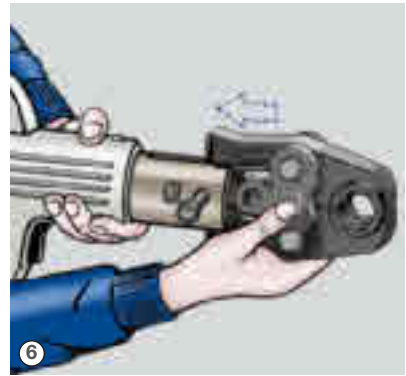

⑥ Place the press jaw onto the press tool. Push in the retaining pin until it snaps into place.

Fig. D – 158  
Fig. D – 159

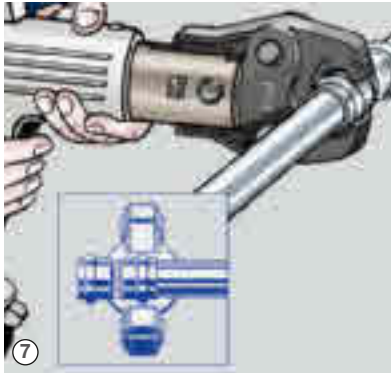

⑦ Open the press jaw and set at a right angle to the connector (check the insertion depth). Start pressing.

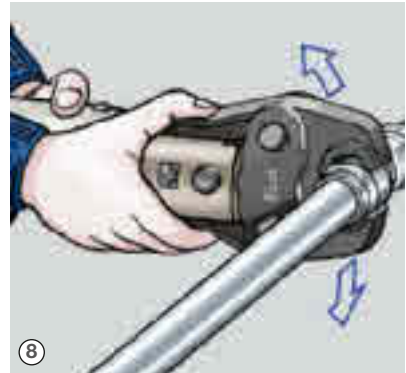

⑧ Once press connector is complete, open the press jaw.

### Sanpress XL – pipe sizes 76.1 – 108.0 mm

The press connection provides an easy and reliable means of connecting stainless steel and copper pipes.

- Pipe cutters or a fine-toothed steel saw
- De-burrer and coloured pen for marking
- Viega press connector machine with jaw suitable for pipe diameter
- Press connector chain of a suitable size

Place the tension jaw on the Viega press connector machine and push in the retaining pin until it snaps into place.

#### Required tools

#### Preparation

#### How to proceed

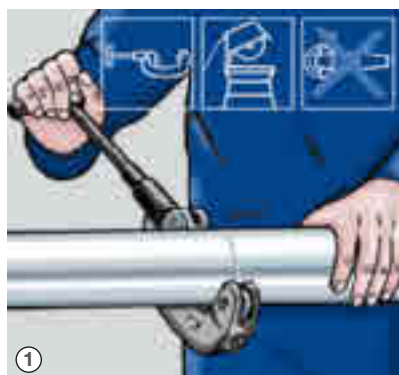

①

Cut the pipe to length at a right angle.

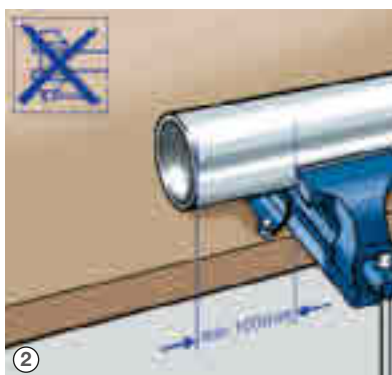

②

Use the vice with caution! The end of the pipe must be perfectly round.

Fig. D – 160  
Fig. D – 161

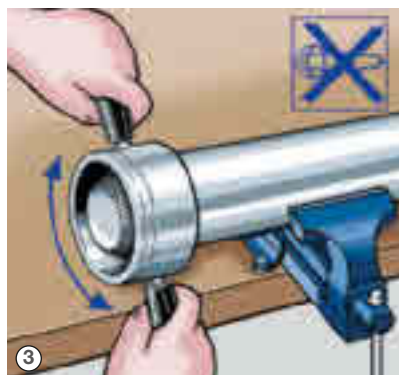

③

De-burr pipe internally and externally.

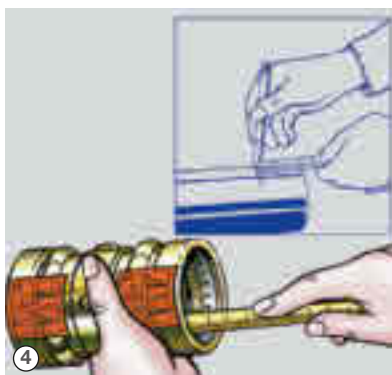

④

Mark the insertion depth.  
 $\varnothing$  64.0 mm = 43 mm  
 $\varnothing$  76.1 mm = 50 mm  
 $\varnothing$  88.9 mm = 50 mm  
 $\varnothing$  108.0 mm = 60 mm

Fig. D – 162  
Fig. D – 163



Fig. D – 164  
Fig. D – 165

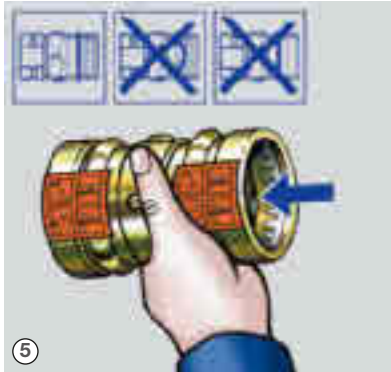

⑤ Check that the sealing element and compression ring are seated correctly.

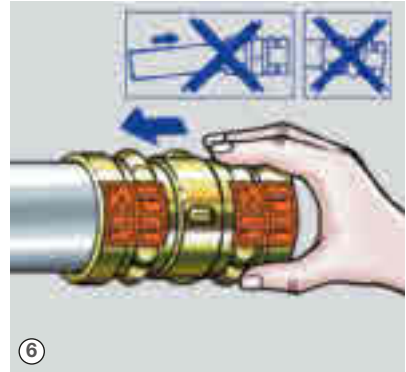

⑥ Slide the press connector onto the pipe as far as the insertion depth marking.

Fig. D – 166  
Fig. D – 167

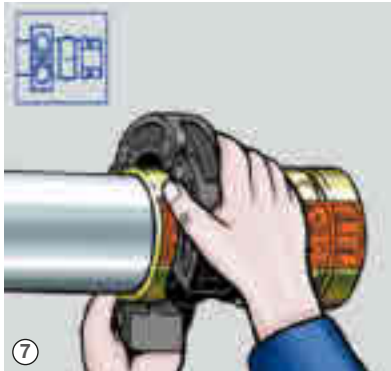

⑦ Place the press ring onto the connector and check that the position is correct.

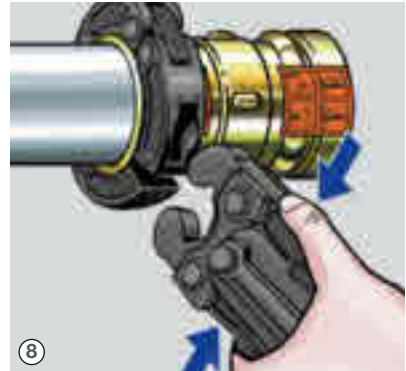

⑧ Open the tension jaw and latch into the receivers on the press ring.

Fig. D – 168  
Fig. D – 169

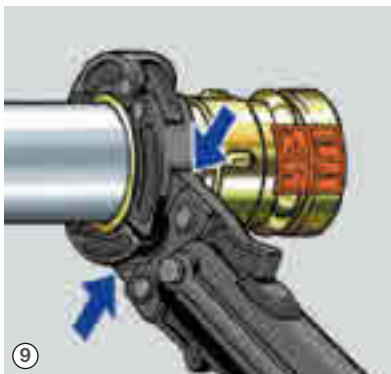

⑨ Connect the press tool and start pressing.

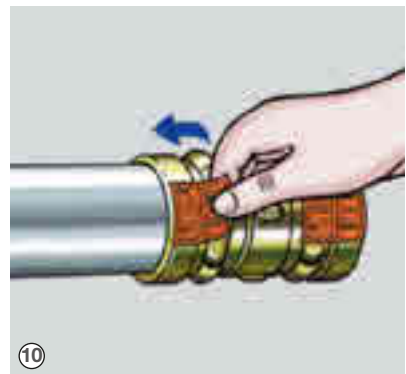

⑩ Remove the control sticker. The connection will now be marked as »pressed«.

**Sanpress Inox XL/Profipress XL – pipe sizes 64.0 – 108.0 mm**

The press connection provides an easy and reliable means of connecting stainless steel pipes.

- Pipe cutters or fine-toothed steel saw
- De-burrer and coloured pen for marking
- Viega press tool with press jaw suitable for pipe diameter

Place the hinged tension jaw on the Viega press tool and push in the retaining pin until it snaps into place.



1 Cut the pipe to length at a right angle.



2 Use the vice with caution! The end of the pipe must be perfectly round.

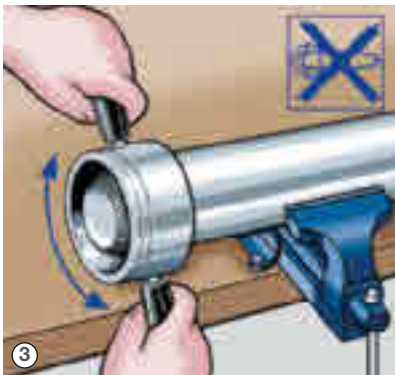

3 De-burr pipe internally and externally.



4 Mark the insertion depth.  
 $\varnothing$  64.0 mm = 43 mm  
 $\varnothing$  76.1 mm = 50 mm  
 $\varnothing$  88.9 mm = 50 mm  
 $\varnothing$  108.0 mm = 60 mm

**Required tools**

**Preparation**

**How to proceed**

Fig. D – 170  
 Fig. D – 171

Fig. D – 172  
 Fig. D – 173

Fig. D – 174  
Fig. D – 175



⑤ Check that the sealing element and compression ring are seated correctly.

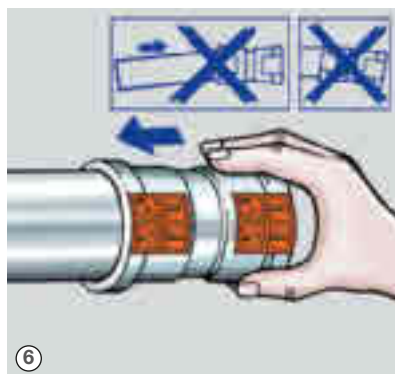

⑥ Slide the press connector onto the pipe as far as the insertion depth marking.

Fig. D – 176  
Fig. D – 177

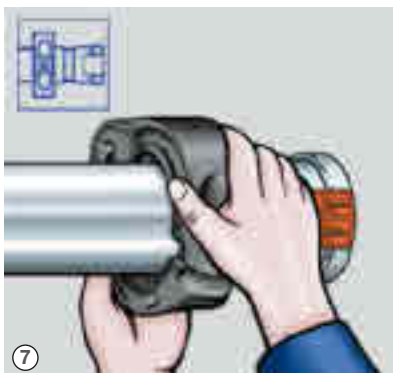

⑦ Place the press ring onto the connector and check that the position is correct.



⑧ Open the hinged tension jaw and latch into the receivers on the press ring.

Fig. D – 178  
Fig. D – 179

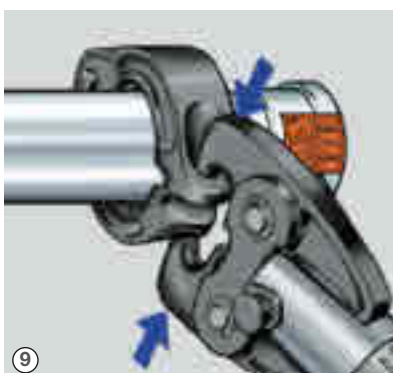

⑨ Start the press tool and start pressing.

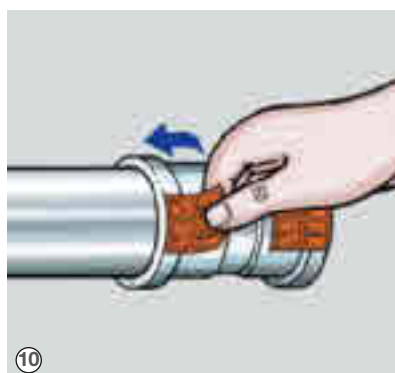

⑩ Remove the control sticker. The connection will now be marked as »pressed«.

## Space requirement for pressing

### Pipe sizes 12–54 mm

For technically flawless press connectors, you need space in which to use the press tool. The following tables contain data indicating the minimum space requirements for a variety of installation conditions.

Note that values for mains operation differ from those for battery operation.

#### Pressing between pipes

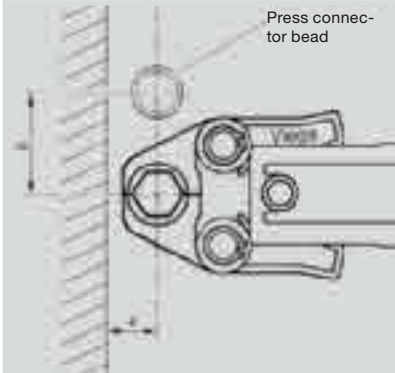

Fig. D – 180

Pipe- $\varnothing$ <sub>a</sub> [mm]	a [mm]	b [mm]
12	20	50
15	20	50
18	20	55
22	25	60
28	25	70
35	30	85
42	45	100
54	50	115

Tab. D – 20

#### Mains operated

Pressgun 4 E, Pressgun 5

PT2

PT3-EH

#### Battery

Pressgun 4 B, Pressgun 5

PT3-AH

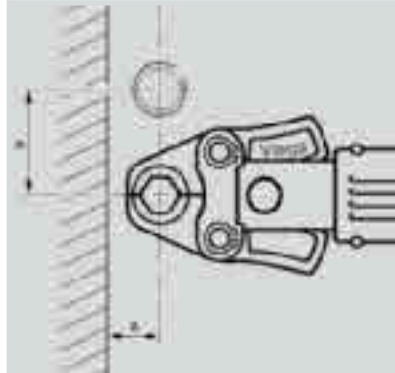

Fig. D – 181

Pipe- $\varnothing$ <sub>a</sub> [mm]	a [mm]	b [mm]
12	25	55
15	25	60
18	25	60
22	25	65
28	25	65

Tab. D – 21

#### Battery

Picco, Pressgun Picco

#### Required space

Pressing against structure

#### Press tool

With different space requirements

**Minimum space requirements**
**Pressgun 5/4B/4E, PT2, PT3-AH, PT3-EH**

Fig. D – 182

Pipe- $\varnothing d_a$ [mm]	a [mm]	b [mm]	c [mm]
12	25	40	65
15	25	40	65
18	25	40	75
22	30	40	80
28	30	50	85
35	50	50	95
42	50	70	115
54	55	80	140

Tab. D – 22

**Picco**

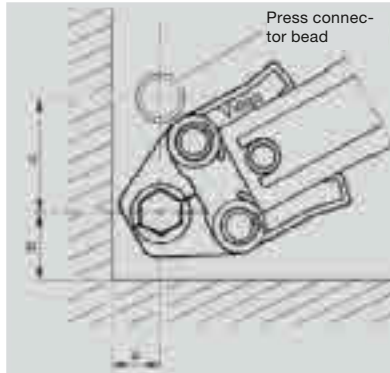
Fig. D – 183

Pipe- $\varnothing d_a$ [mm]	a [mm]	b [mm]	c [mm]
12	30	40	65
15	30	40	70
18	30	40	70
22	30	40	75
28	30	40	80

Tab. D – 23

**Wall spacing**

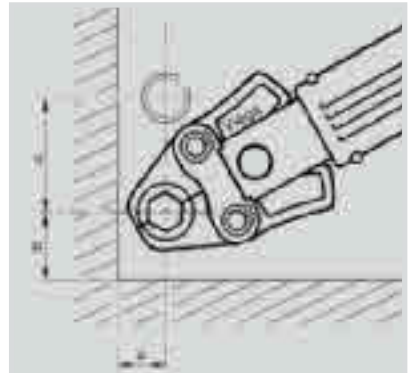
In combination with a tension jaw,  $a_{min}$  can be reduced



Tab. D – 24

**Minimum space requirement  $a_{min}$  [mm]**

Pipe- $\varnothing d_a$ [mm]	PT2	PT3-AH PT3-EH	Picco Pressgun Picco	Pressgun 5/4B/4E
12–54	45	50	35	50

**Distance between pressings**

Canting avoided  
Sealing is assured



Tab. D – 25

Pipe- $\varnothing d_a$ [mm]	Minimum distance a [mm]
12	0
15	0
18	0
22	0
28	0
35	10
42	15
54	25

## Pipe sizes 76.1 – 108.0mm Sanpress XL with ring

Between pipes

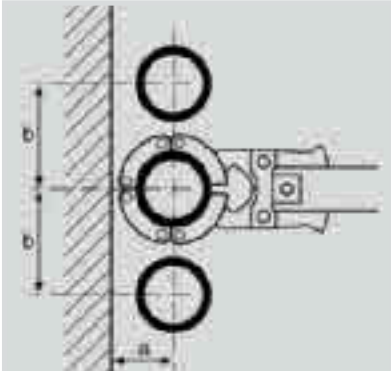

Fig. D – 184

Pipe- $\varnothing$ $d_a$ [mm]	a [mm]	b [mm]
76.1	90	185
88.9	100	200
108.0	110	215

Tab. D – 26

Between pipe and wall

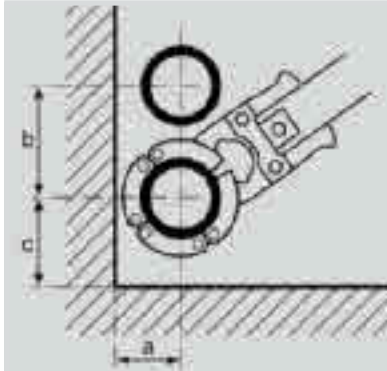



Fig. D – 185

Pipe- $\varnothing$ $d_a$ [mm]	a [mm]	b [mm]	c [mm]
76.1	90	185	130
88.9	100	200	140
108.0	110	215	155

Tab. D – 27

## Space requirement on structures

	Pipe- $\varnothing d_a$	Minimum distance a
	[mm]	[mm]
	76.1	not required!
	88.9	
	108.0	

Tab. D – 28

	Minimum space requirement $a_{min}$ [mm]			
	Pipe- $\varnothing d_a$ [mm]	PT2	PT3-AH	Pressgun 5/4B/4E
	76.1	45	50	50
	88.9			
	108.0			

Tab. D – 29

**Distance between pressings**

Canting avoided

Sealing is assured

**Wall spacing**

Also valid for Sanpress Inox XL and Profipress 64.0mm

## Press tool for Sanpress Inox XL/Profipress 64.0mm

Between pipes

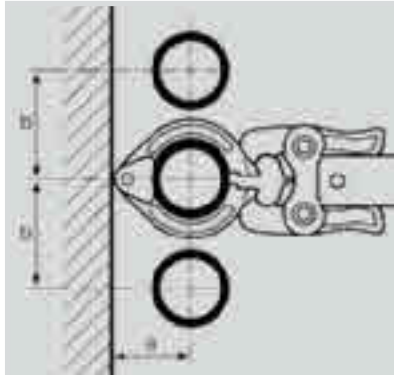

Fig. D – 186

Pipe- $\varnothing d_a$ [mm]	a [mm]	b [mm]
64.0	110	185
76.1		
88.9	120	200
108.0	135	215

Tab. D – 30

Between pipe and wall

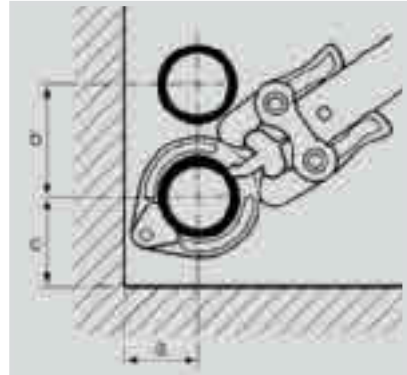

Fig. D – 187

Pipe- $\varnothing d_a$ [mm]	a [mm]	b [mm]	c [mm]
64.0	110	185	130
76.1			
88.9	120	200	140
108.0	135	215	155

Tab. D – 31

**Distance between the press connections**

Canting is avoided, sealing is assured

## Space requirement on structures

	Pipe- $\varnothing d_a$	Minimum distance a
	[mm]	[mm]
	64.0	15
	76.1	
	88.9	
	108.0	

Tab. D – 32

	Pipe- $\varnothing d_a$	Minimum distance a
	[mm]	[mm]
	64.0	20
	76.1	
	88.9	
	108.0	

Tab. D – 33

## Basic rules for commissioning

- Do not fill the supply system until immediately before operation is due to commence. Should commissioning be delayed, the system must be flushed and this process recorded.
- Keep records of leakage testing, flushing, commissioning and training and hand this documentation over to the operator.
- Explain the benefits of a service agreement to the operator.
- Point out the necessity to change the water regularly and completely (approx. three times per week at all points of use).

### SC-Contur

The Viega SC-Contur, which can be found on every Viega press connector, guarantees the identification of non-pressed connections throughout the entire pressure range from 22 mbar to 3 bar (dry) and from 1 bar to 6.5 bar (wet). If the pressure test is carried out during frosty periods, a dry test is recommended in smaller installations as well.

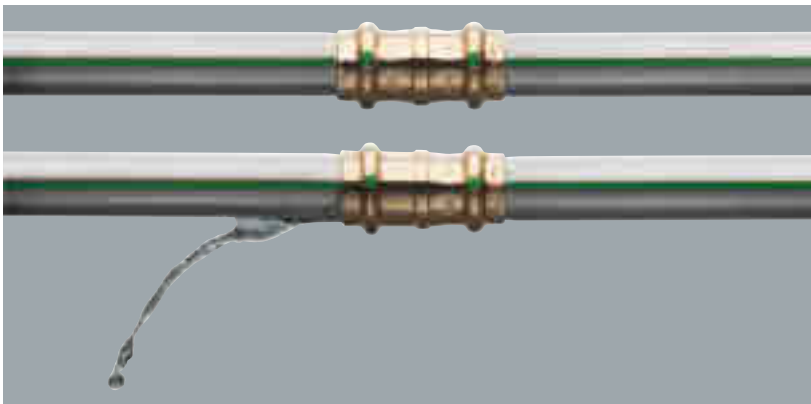

Fig. D – 188

### SC-Contur

Viega Press connectors are fitted with this safety feature. Recognisable by the green dot

### Disinfection

If the water quality does not meet microbiological requirements, it can be disinfected in the Viega press connector system following the disinfection procedures permitted under the terms of the European drinking water ordinance in the defined time periods (total or batch disinfection). The system must always be flushed following disinfection until the concentration of disinfectant meets the concentration levels permissible for continuous disinfection.

We recommend having all disinfection work carried out exclusively by qualified and experienced specialists.

We generally recommend the use of hydrogen peroxide (H<sub>2</sub>O<sub>2</sub>) and chlorine dioxide, preferred on account of their increased material compatibility.

**Problems associated with continuous chlorination**



In accordance with DVGW W 551, 50 mg/l chlorine over 1 – 2 hours is sufficient to disinfect supply systems contaminated with legionella pneumophila. Please refer to the ZVSHK information leaflet entitled »Flushing, disinfecting and commissioning drinking water systems« for more information about the disinfection procedure.

Continuous chlorination compliant with DVGW W 551 – is not suitable for the prophylaxis of legionella pneumophila.

Quote (translated from the original German): »We do not recommend continuous disinfection with chemicals. It will not rid the system of legionella pneumophila.« However, should continuous disinfection prove necessary in the context of a transition phase during modernisation work, this must be carried out in accordance with the terms of the German drinking water ordinance.

Consumers must be informed accordingly (German drinking water ordinance Sections 16 and 20).

European drinking water ordinance specifies limit values for free chlorine of 0.1 to 0.3 mg/l (up to 0.6 mg/l is permitted in exceptional cases approved by the ministry of health). In cases where decentralised disinfection facilities (with the exception of chlorine dioxide) are used in buildings, consumers must prove compliance with the mandatory limit values for trihalogen methane (THM, e.g. chloroform); this is a complex and costly process.

Please contact our Attendorn plant for more information about disinfecting supply systems in buildings in the US.

# Appendix

## Loss of pressure – tables

### Cold water in stainless steel pipes

Pipe friction pressure gradient »R« and flow rate »V« as a function of peak flow rate »Vs« at a temperature of 10 °C for copper and non-corroding steel pipes compliant with DVGW specification sheet W 541.

#### Sizes 15 mm to 54 mm

di (mm) V (l/m)	15 x 1.0mm 13.0 0.13		18 x 1.0mm 16.0 0.20		22 x 1.2mm 19.6 0.30		28 x 1.2mm 25.6 0.51		35 x 1.5mm 32.0 0.80		di (mm) V (l/m)	42 x 1.5mm 39.0 1.19			54 x 1.5mm 51.0 2.04	
	Vs l/s	R mbar/m	V m/s	R mbar/m	V m/s	R mbar/m	V m/s	R mbar/m	V m/s	R mbar/m		V m/s	Vs l/s	R mbar/m	V m/s	R mbar/m
0.05	2.2	0.4	0.8	0.2	0.3	0.2	0.1	0.1	–	–	0.25	0.2	0.2	–	–	
0.08	5.0	0.6	1.9	0.4	0.7	0.3	0.2	0.3	–	–	0.50	0.7	0.4	–	–	
0.10	7.3	0.8	2.7	0.5	1.0	0.3	0.3	0.2	0.1	0.1	0.60	1.0	0.5	–	–	
0.15	14.8	1.1	5.5	0.7	1.9	0.5	0.7	0.3	0.2	0.2	0.70	1.2	0.6	–	–	
0.20	24.5	1.5	9.1	1.0	3.3	0.6	1.1	0.4	0.3	0.2	0.80	1.5	0.7	–	–	
0.25	36.2	1.9	13.5	1.2	5.1	0.8	1.6	0.5	0.5	0.3	0.90	1.8	0.8	–	–	
0.30	49.9	2.3	18.5	1.5	7.1	1.0	2.1	0.6	0.7	0.4	1.00	2.2	0.8	0.5	0.5	
0.35	65.6	2.6	24.3	1.7	9.3	1.2	2.8	0.7	0.9	0.4	1.10	2.6	0.9	0.6	0.5	
0.40	83.1	3.0	30.8	2.0	11.7	1.3	3.6	0.8	1.1	0.5	1.20	3.1	1.0	0.8	0.6	
0.45	102.4	3.4	37.9	2.2	14.4	1.5	4.0	0.9	1.5	0.6	1.30	3.5	1.1	1.0	0.6	
0.50	123.6	3.8	45.7	2.5	17.4	1.7	4.9	1.0	1.7	0.6	1.40	4.0	1.2	1.1	0.7	
0.55	146.5	4.1	54.1	2.7	20.6	1.8	5.8	1.1	2.0	0.7	1.50	4.5	1.3	1.3	0.7	
0.60	171.1	4.5	63.2	3.0	24.0	1.9	6.7	1.2	2.3	0.7	1.60	5.1	1.3	1.4	0.8	
0.65	197.5	4.9	72.9	3.2	27.6	2.2	7.7	1.3	2.7	0.8	1.70	5.7	1.4	1.6	0.8	
0.70			83.2	3.5	31.5	2.3	8.8	1.4	3.0	0.9	1.80	6.3	1.5	1.7	0.9	
0.75			94.1	3.7	35.6	2.5	9.9	1.5	3.4	0.9	1.90	6.9	1.6	1.9	0.9	
0.80			105.6	4.0	40.0	2.7	11.1	1.6	3.8	1.0	2.00	7.6	1.7	2.1	1.0	
0.85			117.6	4.2	44.5	2.8	12.4	1.7	4.2	1.0	2.10	8.2	1.8	2.3	1.0	
0.90			130.3	4.5	49.3	3.0	13.7	1.7	4.7	1.1	2.20	9.0	1.8	2.5	1.1	
0.95			143.6	4.7	54.3	3.1	15.1	1.8	5.2	1.2	2.30	9.7	1.9	2.7	1.1	
1.00			157.4	5.0	59.5	3.3	16.6	1.9	5.7	1.2	2.40	10.5	2.0	2.9	1.2	
1.05					64.9	3.5	18.1	2.0	6.2	1.3	2.50	11.3	2.1	3.1	1.2	
1.10					70.6	3.6	19.6	2.1	6.7	1.4	2.60	12.1	2.2	3.3	1.3	
1.15					76.4	3.8	21.2	2.2	7.3	1.4	2.70	12.9	2.3	3.6	1.3	
1.20					82.5	4.0	22.9	2.3	7.9	1.5	2.80	13.8	2.3	3.8	1.4	
1.25					88.7	4.1	24.6	2.4	8.5	1.5	2.90	14.7	2.4	4.1	1.4	
1.30					95.2	4.3	26.4	2.5	9.1	1.6	3.00	15.6	2.5	4.3	1.5	
1.35					101.9	4.5	28.3	2.6	9.7	1.7	3.50	20.6	2.9	5.7	1.7	
1.40					108.8	4.6	30.1	2.7	10.3	1.7	4.00	26.2	3.4	7.2	2.0	
1.45					115.8	4.8	32.1	2.8	11.0	1.8	4.50	32.4	3.7	9.0	2.2	
1.50					123.1	5.0	34.1	2.9	11.7	1.9	5.00	39.1	4.2	10.8	2.5	
1.55					130.6	5.1	36.2	3.0	12.4	1.9	5.50	46.5	4.6	12.8	2.7	
1.60					138.3	5.3	38.3	3.1	13.1	2.0	6.00	53.8	5.0	14.9	2.9	
1.65							40.4	3.2	13.8	2.1	6.50			17.3	3.2	
1.70							42.7	3.3	14.6	2.1	7.00			19.7	3.4	
1.75							44.9	3.4	15.4	2.2	7.50			22.3	3.7	
1.80							47.3	3.5	16.2	2.2	8.00			25.1	3.9	
1.85							49.6	3.6	17.0	2.3	8.50			28.0	4.2	
1.90							52.1	3.7	17.8	2.4	9.00			31.3	4.4	
1.95							54.6	3.8	18.7	2.4	9.50			34.3	4.7	
2.00							57.1	3.9	19.5	2.5	10.00			37.6	4.9	
2.10							62.3	4.1	21.3	2.6						
2.20							67.8	4.3	23.1	2.7						
2.30							73.4	4.5	25.1	2.9						
2.40							79.3	4.7	27.1	3.0						
2.50							85.3	4.9	29.1	3.1						
2.60									31.2	3.2						
2.70									33.4	3.4						
2.80									35.7	3.5						
2.90									38.0	3.6						
3.00									40.4	3.7						
3.25									46.9	4.0						
3.50									53.3	4.4						
3.75									60.4	4.7						
4.00									67.9	5.0						

Tab. D – 34

## Cold water in stainless steel pipes

## XL-Sizes 64.0 to 108.0mm

di (mm) V (l/m)	64.0 x 2.0mm 60.0 2.83		76.1 x 2.0mm 72.1 4.08		88.9 x 2.0mm 84.9 5.66		108.0 x 2.0mm 104.0 8.49	
	Vs l/s	R mbar/m	V m/s	R mbar/m	V m/s	R mbar/m	V m/s	R mbar/m
0.60	0.1	0.2	-	-	-	-	-	-
0.80	0.2	0.3	-	-	-	-	-	-
1.00	0.3	0.4	0.1	0.2	0.1	0.2	-	-
1.20	0.4	0.4	-	-	-	-	-	-
1.40	0.5	0.5	-	-	-	-	-	-
1.50	-	-	0.2	0.4	0.1	0.3	-	-
1.60	0.6	0.6	-	-	-	-	-	-
1.80	0.8	0.6	-	-	-	-	-	-
2.00	1.0	0.7	0.4	0.5	0.2	0.4	0.1	0.2
2.20	1.1	0.8	-	-	-	-	-	-
2.40	1.3	0.8	-	-	-	-	-	-
2.50	-	-	0.6	0.6	0.3	0.4	0.1	0.3
2.60	1.5	0.9	-	-	-	-	-	-
2.80	1.8	1.0	-	-	-	-	-	-
3.00	2.0	1.1	0.8	0.7	0.4	0.5	0.1	0.4
3.20	2.2	1.1	-	-	-	-	-	-
3.40	2.5	1.2	-	-	-	-	-	-
3.50	-	-	1.1	0.9	0.5	0.6	0.2	0.4
3.60	2.7	1.3	-	-	-	-	-	-
3.80	3.0	1.3	-	-	-	-	-	-
4.00	3.3	1.4	1.4	1.0	0.6	0.7	0.2	0.5
4.20	3.6	1.5	-	-	-	-	-	-
4.40	3.9	1.6	-	-	-	-	-	-
4.50	-	-	1.7	1.1	0.8	0.8	0.3	0.5
4.60	4.2	1.6	-	-	-	-	-	-
4.80	4.6	1.7	-	-	-	-	-	-
5.00	4.9	1.8	2.0	1.2	0.9	0.9	0.4	0.6
5.20	5.3	1.8	-	-	-	-	-	-
5.40	5.7	1.9	-	-	-	-	-	-
5.50	-	-	2.4	1.3	1.1	1.0	-	-
5.60	6.0	2.0	-	-	-	-	-	-
5.80	6.4	2.1	-	-	-	-	-	-
6.00	6.8	2.1	2.8	1.5	1.3	1.1	0.5	0.7
6.50	7.9	2.3	3.3	1.6	-	-	-	-
7.00	9.0	2.5	3.7	1.7	1.7	1.2	0.7	0.8
7.50	10.6	2.7	4.2	1.9	-	-	-	-
8.00	11.5	2.8	4.7	2.0	2.2	1.4	0.9	1.0
8.50	12.8	3.0	5.3	2.1	-	-	-	-
9.00	14.2	3.2	5.9	2.2	2.7	1.6	1.1	1.1
9.50	15.7	3.4	6.5	2.3	-	-	-	-
10.00	17.2	3.5	7.1	2.4	3.2	1.8	1.2	1.2
11.00	20.4	3.9	8.4	2.7	3.8	1.9	1.5	1.3
12.00	23.9	4.2	9.9	2.9	4.5	2.1	1.8	1.4
13.00	27.6	4.6	11.4	3.2	5.2	2.3	2.0	1.6
14.00	31.6	5.0	13.0	3.4	5.9	2.5	2.3	1.7
15.00			14.8	3.7	6.7	2.6	2.5	1.8
16.00			16.6	3.9	7.5	2.8	2.8	1.9
17.00			18.5	4.2	8.4	3.0	3.2	2.0
18.00			20.5	4.4	9.3	3.2	3.5	2.2
19.00			22.7	4.7	10.3	3.4	3.9	2.3
20.00			24.9	4.9	11.3	3.5	4.3	2.4
21.00			27.2	5.1	12.3	3.7	4.7	2.5
22.00					13.4	3.9	5.1	2.6
23.00					14.6	4.1	5.5	2.7
24.00					15.7	4.2	5.9	2.8
25.00					17.0	4.4	6.4	2.9
30.00					23.4	5.3	9.0	3.5
35.00							11.8	4.1
40.00							15.0	4.7
45.00							18.6	5.3

Tab. D – 35

## Warm water in stainless steel pipes

Pipe friction pressure gradient »R« and flow rate »V« as a function of peak flow rate »Vs« at a temperature of 60 °C for copper and non-corroding steel pipes compliant with DVGW specification sheet W 541.

### Sizes 15mm to 54mm

di (mm) V (l/m)	15 x 1.0mm 13.0 0.13		18 x 1.0mm 16.0 0.20		22 x 1.2mm 19.6 0.30		28 x 1.2mm 25.6 0.51		35 x 1.5mm 32.0 0.80		di (mm) V (l/m)	42 x 1.5mm 39.0 1.19		54 x 1.5mm 51.0 2.04	
	Vs l/s	R mbar/m	V m/s	R mbar/m	V m/s	R mbar/m	V m/s	R mbar/m	V m/s	R mbar/m		V m/s	Vs l/s	R mbar/m	V m/s
0.05	1.7	0.4	0.6	0.3	0.2	0.2	0.1	0.1	–	–	0.25	0.1	0.2	–	–
0.08	3.8	0.6	1.4	0.4	0.5	0.3	0.2	0.2	–	–	0.50	0.5	0.4	–	–
0.10	5.6	0.8	2.1	0.5	0.8	0.3	0.2	0.2	0.1	0.1	0.60	0.7	0.5	–	–
0.15	11.4	1.1	4.2	0.8	1.6	0.5	0.5	0.3	0.2	0.2	0.70	0.9	0.6	–	–
0.20	19.1	1.5	7.0	1.0	2.7	0.7	0.8	0.4	0.3	0.3	0.80	1.2	0.7	–	–
0.25	28.4	1.9	10.5	1.2	4.0	0.8	1.1	0.5	0.4	0.3	0.90	1.4	0.8	–	–
0.30	39.4	2.5	14.5	1.5	5.5	1.0	1.5	0.6	0.5	0.4	1.00	1.7	0.8	0.5	0.5
0.35	52.1	2.6	19.1	1.7	7.2	1.2	2.0	0.7	0.7	0.4	1.10	2.1	0.9	0.6	0.5
0.40	66.3	3.0	24.3	2.0	9.2	1.3	2.6	0.8	0.9	0.5	1.20	2.4	1.0	0.7	0.6
0.45	82.0	3.4	30.1	2.2	11.3	1.5	3.1	0.9	1.1	0.6	1.30	2.8	1.1	0.8	0.6
0.50	99.3	3.8	36.4	2.5	13.7	1.7	3.8	1.0	1.3	0.6	1.40	3.2	1.2	0.9	0.7
0.55	118.1	4.1	43.2	2.7	16.2	1.8	4.5	1.1	1.5	0.7	1.50	3.6	1.3	1.0	0.7
0.60	138.4	4.5	50.6	3.0	19.0	2.0	5.3	1.2	1.8	0.8	1.60	4.0	1.3	1.1	0.8
0.65	160.2	4.9	58.5	3.2	21.9	2.2	6.1	1.3	2.1	0.8	1.70	4.5	1.4	1.2	0.8
0.70	183.4	5.3	66.9	3.5	25.1	2.3	6.9	1.4	2.4	0.9	1.80	5.0	1.5	1.4	0.9
0.75			75.9	3.7	28.4	2.5	7.8	1.5	2.7	0.9	1.90	5.5	1.6	1.5	0.9
0.80			85.3	4.0	31.9	2.7	8.8	1.6	3.0	1.0	2.00	6.0	1.7	1.7	1.0
0.85			95.3	4.2	35.6	2.8	9.8	1.7	3.4	1.1	2.10	6.6	1.8	1.8	1.0
0.90			105.8	4.5	39.5	3.0	10.9	1.8	3.7	1.1	2.20	7.2	1.8	2.0	1.1
0.95			116.7	4.7	43.6	3.2	12.0	1.9	4.1	1.2	2.30	7.8	1.9	2.1	1.1
1.00			128.2	5.0	47.9	3.3	13.2	1.9	4.5	1.2	2.40	8.4	2.0	2.3	1.2
1.05			140.2	5.2	52.3	3.5	14.4	2.0	4.9	1.3	2.50	9.1	2.1	2.5	1.2
1.10			152.7	5.5	56.9	3.7	15.6	2.1	5.3	1.4	2.60	9.7	2.2	2.7	1.3
1.15					61.7	3.8	17.0	2.2	5.8	1.4	2.70	10.4	2.3	2.9	1.3
1.20					66.7	4.0	18.3	2.3	6.2	1.5	2.80	11.1	2.3	3.0	1.4
1.25					71.9	4.1	19.7	2.4	6.7	1.6	2.90	11.9	2.4	3.2	1.4
1.30					77.2	4.3	21.2	2.5	7.2	1.6	3.00	12.6	2.5	3.5	1.5
1.35					82.7	4.5	22.7	2.6	7.7	1.7	3.50	16.7	2.9	4.6	1.7
1.40					88.4	4.6	24.2	2.7	8.2	1.7	4.00	21.3	3.4	5.8	2.0
1.45					94.3	4.8	25.8	2.8	8.8	1.8	4.50	26.5	3.7	7.2	2.2
1.50					100.3	5.0	27.4	2.9	9.3	1.9	5.00	32.1	4.2	8.7	2.5
1.55					106.6	5.1	29.1	3.0	9.9	1.9	5.50	38.3	4.6	10.4	2.7
1.60					112.9	5.3	30.9	3.1	10.5	2.0	6.00	44.9	5.0	12.2	2.9
1.65					119.5	5.5	32.6	3.2	11.1	2.1	6.50			14.1	3.2
1.70					126.3	5.6	34.5	3.3	11.7	2.1	7.00			16.2	3.4
1.75							36.3	3.4	12.3	2.2	7.50			18.3	3.7
1.80							38.3	3.5	13.0	2.2	8.00			20.6	3.9
1.85							40.2	3.6	13.6	2.3	8.50			23.1	4.2
1.90							42.2	3.7	14.3	2.4	9.00			25.6	4.4
1.95							44.3	3.8	15.0	2.4	9.50			28.3	4.7
2.00							46.4	3.9	15.7	2.5	10.00			31.1	4.9
2.10							50.7	4.1	17.2	2.6					
2.20							55.2	4.3	18.7	2.7					
2.30							59.9	4.5	20.3	2.9					
2.40							64.7	4.7	21.9	3.0					
2.50							69.8	4.9	23.6	3.1					
2.60							75.0	5.1	25.4	3.2					
2.70							80.4	5.2	27.2	3.4					
2.80							85.9	5.4	29.0	3.5					
2.90							91.7	5.6	31.0	3.6					
3.00									32.9	3.7					
3.25									38.1	4.0					
3.50									43.7	4.4					
3.75									49.6	4.7					
4.00									55.8	5.0					

Tab. D – 36

## Loss of Pressure: Warm water in stainless steel pipes

## XL-Sizes 64.0 to 108.0mm

di (mm)	64.0 x 2.0mm		76.1 x 2.0mm		88.9 x 2.0mm		108.0 x 2.0mm	
	60.0 2.83 mm	60.0 2.83 mm	72.1 4.08	72.1 4.08	84.9 5.66	84.9 5.66	104.0 8.49	104.0 8.49
V (l/m)	R mbar/m	V m/s	R mbar/m	V m/s	R mbar/m	V m/s	R mbar/m	V m/s
0.60	0.1	0.2	-	-	-	-	-	-
0.80	0.8	0.3	-	-	-	-	-	-
1.00	0.2	0.4	0.1	0.2	-	-	-	-
1.20	0.3	0.4	-	-	-	-	-	-
1.40	1.4	0.5	-	-	-	-	-	-
1.50	-	-	0.2	0.4	0.1	0.3	-	-
1.60	0.5	0.6	-	-	-	-	-	-
1.80	0.6	0.6	-	-	-	-	-	-
2.00	0.8	0.7	0.3	0.5	0.1	0.4	0.1	0.2
2.20	0.9	0.8	-	-	-	-	-	-
2.40	1.1	0.8	-	-	-	-	-	-
2.50	-	-	0.5	0.6	0.2	0.4	0.1	0.3
2.60	1.2	0.9	-	-	-	-	-	-
2.80	1.4	1.0	-	-	-	-	-	-
3.00	1.6	1.1	0.7	0.7	0.3	0.5	0.1	0.4
3.20	1.8	1.1	-	-	-	-	-	-
3.40	2.0	1.2	-	-	-	-	-	-
3.50	-	-	0.9	0.9	0.4	0.6	0.1	0.4
3.60	2.2	1.3	-	-	-	-	-	-
3.80	3.8	1.3	-	-	-	-	-	-
4.00	2.7	1.4	1.1	1.0	0.5	0.7	0.2	0.5
4.20	2.9	1.5	-	-	-	-	-	-
4.40	3.2	1.6	-	-	-	-	-	-
4.50	-	-	1.4	1.1	0.6	0.8	0.2	0.5
4.60	3.4	1.6	-	-	-	-	-	-
4.80	3.7	1.7	-	-	-	-	-	-
5.00	4.0	1.8	1.6	1.2	0.7	0.9	0.3	0.6
5.20	4.3	1.8	-	-	-	-	-	-
5.40	5.4	1.9	-	-	-	-	-	-
5.50	-	-	2.0	1.3	0.9	1.0	0.3	0.6
5.60	4.9	2.0	-	-	-	-	-	-
5.80	5.2	2.1	-	-	-	-	-	-
6.00	5.5	2.1	2.3	1.5	1.0	1.1	0.4	0.7
6.50	6.4	2.3	2.6	1.6	1.2	1.1	0.5	0.8
7.00	7.3	2.5	3.0	1.7	1.4	1.2	0.5	0.8
7.50	8.3	2.7	3.4	1.8	1.6	1.3	0.6	0.9
8.00	9.4	2.8	3.9	2.0	1.7	1.4	0.7	0.9
8.50	10.5	3.0	4.3	2.1	2.0	1.5	0.7	1.0
9.00	11.6	3.2	4.8	2.2	2.2	1.6	0.8	1.1
9.50	12.8	3.4	5.3	2.3	2.4	1.7	0.9	1.1
10.00	14.1	3.5	5.8	2.4	2.6	1.8	1.0	1.2
11.00	16.8	3.9	6.9	2.7	3.1	1.9	1.2	1.3
12.00	19.7	4.2	8.1	2.9	3.7	2.1	1.4	1.4
13.00	22.9	4.6	9.4	3.2	4.2	2.3	1.6	1.5
14.00	26.2	5.0	10.7	3.4	4.9	2.5	1.8	1.6
15.00	29.8	5.3	12.2	3.7	5.5	2.6	2.1	1.8
16.00			13.7	3.9	6.2	2.8	2.3	1.9
17.00			15.3	4.2	6.9	3.0	2.6	2.0
18.00			17.0	4.4	7.7	3.2	2.9	2.1
19.00			18.8	4.7	8.5	3.4	3.2	2.2
20.00			20.7	4.9	9.3	3.5	3.5	2.4
21.00			22.6	5.1	10.2	3.7	3.8	2.5
22.00			24.7	5.4	11.1	3.9	4.2	2.6
23.00					12.1	4.1	4.5	2.7
24.00					13.1	4.2	4.9	2.8
25.00					14.1	4.4	5.3	2.9
30.00					19.7	5.3	7.3	3.5
35.00							9.8	4.1
40.00							12.5	4.7
45.00							15.5	5.3

Tab. D – 37



## Report – Flushing with water

Building project \_\_\_\_\_

Customer represented by \_\_\_\_\_

1. Pressure testing was performed on \_\_\_\_\_

2. Pipe system material \_\_\_\_\_

3. Table: Standard values for the minimum number of points of use to be opened based on the largest nominal width of the distribution piping system

<b>Largest nominal width of the distribution pipeline in current flushing section</b>	25	32	40	50	65	80	100
<b>Minimum number of extraction points to be opened</b>	2	4	6	8	12	18	28

4. On a single floor, the points of use are opened starting with the point of use furthest away from the riser run.

After a 5-minute flushing period at the last flushing point opened, the points of use are closed one after the other in the reverse order.

5. The drinking water used for flushing is filtrated. Static pressure  $P_W =$  \_\_\_\_\_ bar.

6. Maintenance fittings (floor shut-off devices, preliminary shutoff devices) are opened fully.

7. Sensitive fittings and instruments are dismantled and replaced by adapters or bridged by flexible lines.

8. Water jet regulators, aerators, flow limiters are dismantled.

9. Installed dirt trap sieves and dirt traps in front of fittings are to be cleaned after flushing with water.

10. Starting from the main shutoff valve, the system is flushed in sequence section by section as far as the furthest point of use.

The drinking water system has been properly flushed

Place \_\_\_\_\_

Date \_\_\_\_\_

\_\_\_\_\_  
Signature of Customer/Representative

\_\_\_\_\_  
Signature Contractor/Representative

Systems: Sanpress, Sanpress Inox, Profipress – Test medium: Compressed air or inert gas

Building project \_\_\_\_\_  
 \_\_\_\_\_  
 Building section \_\_\_\_\_  
 Customer represented by \_\_\_\_\_  
 Contractor represented by \_\_\_\_\_  
 Pipe system material \_\_\_\_\_  
 Type of connection \_\_\_\_\_  
 System pressure \_\_\_\_\_ bar  
 Ambient temperature \_\_\_\_\_ °C  
 Test medium \_\_\_\_\_ °C

Test medium  Oil-free compressed air  Nitrogen  Carbon dioxide  
 The drinking water system has been tested as  Complete unit  In \_\_\_\_\_ sections

All pipes are closed with metallic plugs, caps, blanking disks or blanking-off flanges.  
 Instruments, pressure vessels or drinking water heaters are isolated from the pipes.  
 A visual check of all pipe connections to ensure that these are correct has been carried out.

**1. Leakage test**

Test pressure 110 mbar  
 Up to 100 litres of pipe capacity minimum test period 30 minutes; the test period must be increased by a further 10 minutes for each additional 100 litres.

Piping system capacity \_\_\_\_\_ litres Test period \_\_\_\_\_ minutes

Wait for temperature adjustment and steady-state condition with plastic materials before starting the test period.

	<b>Yes</b>	<b>No</b>
Carry out a visual check of line system/check using a pressure gauge U-tube/standpipe water column carried out?	<input type="checkbox"/>	<input type="checkbox"/>
Any evidence of air passing through during leak testing?	<input type="checkbox"/>	<input type="checkbox"/>

**2. Load test under increased pressure**

Wait for temperature adjustment and steady-state condition with plastic materials before starting the test period.

Test pressure ≤ DN50 max. 3 bar  Test pressure > DN50 max. 1 bar  Test pressure: 10 Minutes

Place \_\_\_\_\_ Date \_\_\_\_\_

\_\_\_\_\_  
 Signature of Customer/Representative Signature Contractor/Representative



# Report – Pressure test for drinking water supply systems

## Systems: Sanpress, Sanpress Inox, Profipress – Test medium: Water

Pressure gauges which will clearly indicate pressure changes of 0.1 mbar must be used.

Building project \_\_\_\_\_  
\_\_\_\_\_

Building section \_\_\_\_\_

Customer represented by \_\_\_\_\_

Contractor represented by \_\_\_\_\_

Have all vessels, appliances and fittings which are not suitable for pressurisation been isolated from the system/section to be tested during the pressure test? **Yes**  **No**

Has the system/section to be tested been filled with filtrated water and completely vented?

### SC-Contur functional test

In the event of significant temperature differences (10 K) between ambient and fill-up water temperature, has a 30-minute waiting time for temperature adjustment been adhered to following establishment of the test pressure?

Pressure corresponds to the available supply pressure of \_\_\_\_ bar but does not exceed 6.5 bar!

Carry out a visual check of line system/check using a pressure gauge

Did the pressure drop during the functional test?

Were any leaks detected during the functional test?

### System pressure test

Was pressure testing of the drinking water supply system carried out at a minimum test pressure of 15 bar?

The test period is 10 minutes.

Did the pressure drop during the test period?

Were any leaks detected during the test period?

Place \_\_\_\_\_

Date \_\_\_\_\_

\_\_\_\_\_  
Signature of Customer/Representative

\_\_\_\_\_  
Signature Contractor/Representative



## Combination of pipe materials in drinking water installations



Fig. D – 189

This chapter gives us an overview of the relevant aspects concerning the planning and application of metallic Viega piping and press connector systems. In practice, there are requirements relating to storey distributors, which, in addition to metallic cellar distributors and riser pipes, can be fulfilled excellently using plastic piping systems. PE-Xc pipes with PE-protective pipes have been especially effective here.

Viega produces these types of piping systems as well as pre-wall installation systems with flushing technology for wall-hung WCs and urinals in its range. Further details can be found in Application Technology Vol. 2 and on your national Viega website.

# 2 Heating technology

## Copper piping systems

### Profipress – System description

#### Intended use

Profipress is a heating installation system with press connecting technology especially for the connection of heating boilers and units in warm water heating system. The system is designed for heating installations according to EN 12828

- Operating temperature  $T_{\max} \leq 105^{\circ}\text{C}$
- Performance  $\leq 1\text{ MW}$ .

Apart from drinking water pipes with a wall thickness of at least 1 mm, heating systems with copper pipes with smaller wall strengths according to EN 1057<sup>1</sup> can be used.

You must seek approval from Viega Service Center before using Profipress in any application other than those described.

- Manifold
- Manifold and riser pipes
- Solar thermic systems
- Distance heating systems (>110°C – with FKM-sealing element)



Fig. H – 1



Fig. H – 2

<sup>1</sup> Regard the minimum wallthickness acc. to Tab. H – 1

#### Other uses

#### Connectors

With press- and threaded connectors

**Pipe material**
**Press connector-material**
**Sealing element**
**Pipe delivery condition**
**Approval**

System

Pipes

**Nominal size [mm]**

Profipress

Profipress XL

**Technical data**

 Copper pipes according to EN 1057 (Minimum wallthickness see *Tab. H-1*)

- Press connector 12 – 108.0mm copper
- Press connector with threaded joint
  - 12 – 54 mm gunmetal
  - 64.0 – 108.0mm copper

Black; EPDM (ethylene propylene diene rubber) up to 110 °C; not resistant to hydrocarbon solutions or chlorinated hydrocarbons, turpentine and petrol

Rod and rolls (see table)

 Profipress with SC-Contur DVGW-Reg.-Nr. DW-8511AP3139

 Profipress XL DVGW-Reg.-Nr. DW-8511AT2347

Copper pipes according to EN 1057

**Copper pipes to be used in Heating installations**

d x s <sub>min</sub> [mm]	Volume per running metre of pipe [Litre/m]	Size	Material Press connector
12 x 0.7	0.09	Standard	Copper
15 x 0.8	0.14		
18 x 0.8	0.21		
22 x 0.9	0.32		
28 x 1.0	0.53		
35 x 1.0	0.83		
42 x 1.0	1.26		
54 x 1.2	2.04		
<b>Profipress-XL</b>			
64.0 x 2.0	2.83	XL	Copper
76.1 x 2.0	4.08		
88.9 x 2.0	5.66		
108.0 x 2.5	8.33		

*Tab. H – 2*

## Components



Fig. H–3

### Pipes

Alongside drinking water pipes with a wall thicknesses of at least 1 mm, heating systems with copper pipes with smaller wall thicknesses according to EN 1057 can be used (Minimum wallthickness see *Tab. H–1*).

### Press connectors

The comprehensive Profipress range allows a great number of installation and connection possibilities in the boiler and fitting connection field as well as with boiler, manifolds and risers. XL-Sizes are identical to those of the drinking water installation.

The construction of prefabricated manifold systems and the connection of valves, fittings and appliances is made possible by flanges, adapters and threaded connectors with a direct press connection.

Profipress components  
see chapter  
»Drinking water  
installation«

**Profipress-connectors**

The green dot as a mark of the SC-Contur



Fig. H – 4

With all the advantages of the Viega system range

- Tested according to DVGWW534
- SC-Contur
- Press connection for nearly all connection variations
- Press machine with battery or mains powered
- More than 500 System-components

**Profipress – XL-Sizes**

d x s [mm]	Volume per running. metre of pipe [Litre/m]	Size	Material Press connector
64.0 x 2.0	2.83	XL	Copper
76.1 x 2.0	4.08		
88.9 x 2.0	5.66		
108.0 x 2.5	8.33		

Tab. H – 3

All sizes are identical to those of the drinking water installation. The construction of prefabricated manifold systems and the connection of valves, fittings and appliances is made possible by flanges, adapters and threaded connectors with a direct press connection.

**Copper connectors**

For the connection of fittings and valves



Fig. H – 5

### Easytop-ball valves

Easytop-ball valves are suitable for heating installations according to EN 12828 and configured for a maximum operating temperature of 105 °C. They are the preferred choice for manifold installation and the installation of connection and maintenance fittings, units and apparatus and storey and riser pipe shut-offs.

Coloured caps make it possible to colour code the different media for example heating supply; red, heating backflow; blue a new addition to the easy top ball valve range is the ball valve with pump connection optional with a gravity brake.



Fig. H – 6

### Heating manifold with expansion of the heating system

- Easytop-ball valves as shut-off fittings
- Exchangeable cover plates red/blue for supply and backflow

## Sealing elements

### Factory fitted EPDM sealing elements

- Maximum safe operating temperature  $T_{\max} = 110\text{ °C}$
- Maximum operating pressure  $p_{\max} = 10\text{ bar}$
  
- FKM sealing elements (special accessory)
- Maximum operating temperature  $T_{\max} = 140\text{ °C}$
- Maximum operating pressure  $p_{\max} = 16\text{ bar}$

The factory fitted seal elements made of (black) EPDM offer enough safety precautions for typical applications in building technology.

In case of higher requirements for example for solar pipe collectors FKM sealing elements can be ordered and manually exchanged, also the Pro-fipress S system can be used (fittings assembled with FKM sealing elements).

FKM sealing elements may not be used for gas and drinking water installations.

## Application technology

### Riser pipes

In cross connections water flows around the internal pipe, this principle allows pipes on the same level to be crossed. The assembly takes place flat on the wall or in floor space.

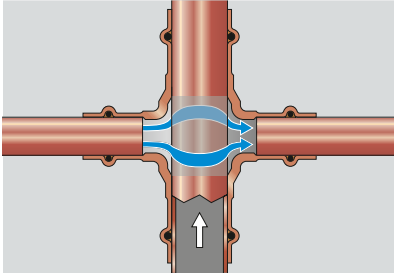

Fig. H – 7

### Advantages

- Low installation height
- Installation on one level
- Breaking work no longer necessary
- Ideal in cramped conditions
- Easy installation even on the floor
- Less material required

The cross pieces and the bridging piece make it possible for direct connection on the riser, even in very cramped conditions.



Fig. H – 8

### Advantages

- Time saving assembly
- Suitable for cramped conditions
- Optically attractive visible installations
- Tried and tested solution for public buildings

**Cross connection**

**Radiator connection**

Both-sided taken from the riser pipe



**Radiator-backflow connection**

In angled and straight through versions with press sleeve for direct pressing

**Radiator connection**

Renovation without the danger of fire

**Back flow connection**

Backflow connections for radiators can be supplied with press connections in angled or straight through versions.



Fig. H – 9

**Advantages**

- Cold press connection technology: no extra work with soldering iron
- No time lost dismantling heat sensitive seals and re-assembly after cooling phase
- No burnt or melted connection points
- Optically attractive gun metal, nickel plated



Fig. H – 10

Burn marks and traces of handling may be unavoidable with soldering



Fig. H – 11

The cold press connection technology – clean work from the beginning

## Radiator connections

### With Central Floor manifold

The Floor manifold – also allowed in inaccessible areas – avoids the crossing of pipes. *Fig. H-12* shows the radiator connection via many interconnected Floor manifolds in connection with factory insulated copper pipe

- Space saving as no heat circuit manifold necessary
- Crossing free pipes with low floor construction height
- Short assembly time
- No extra connections necessary
- Installation of the complete floor distribution with press connectors

Three interconnected Floor manifolds supply four outlets for radiator connection. It is possible to fit a reducer sleeve at the manifold end (e.g. 22 x 15).

When turning on a Floor manifold, observe supply and backflow.

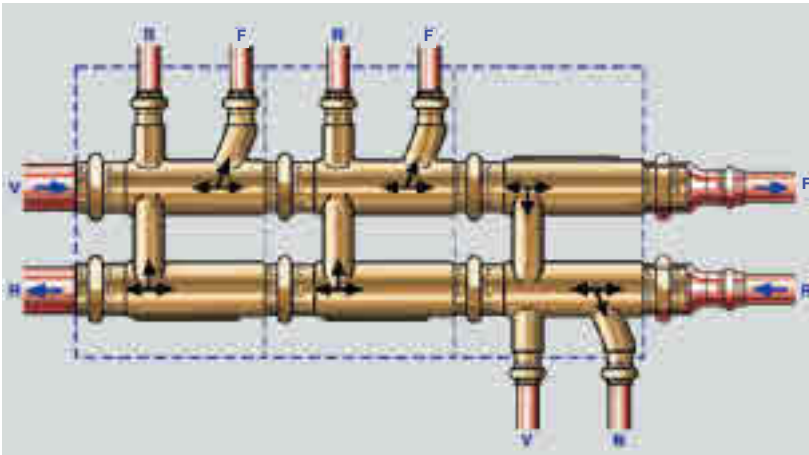

*Fig. H – 12*

### Advantages of the Floor manifold

### Manifold-extension

### Floor manifold

As central manifold for apartment

**Radiator connection**

Out of the floor via the central Floor manifold

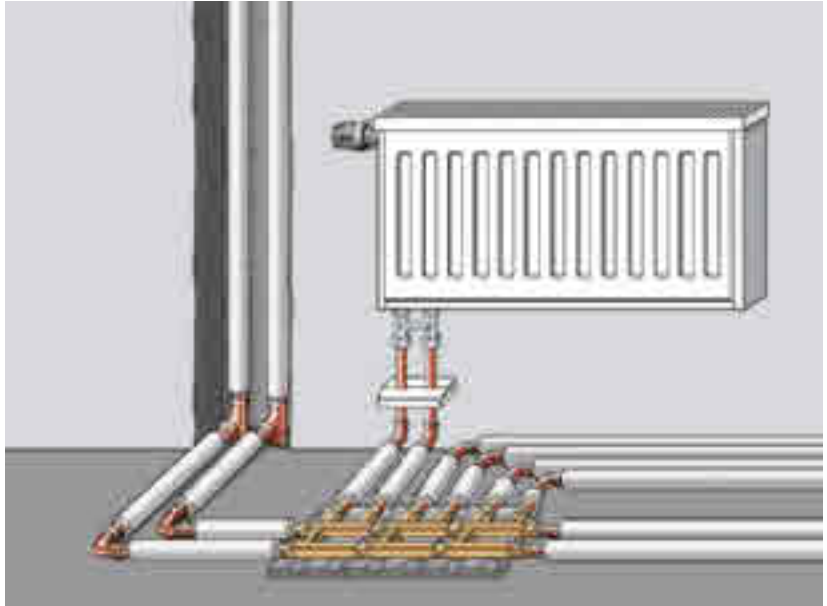

Fig. H – 13

**Possible applications**

- For radiator connection via multiple connected Floor manifolds
- For installation in inaccessible areas, avoids the overlaying of pipes and allows the professional insertion in the floor

**Floor manifold**

With insulation box



Fig. H – 14

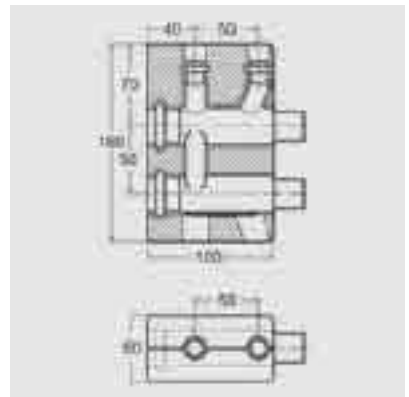

Fig. H – 15

With Crossover-tee



Fig. H – 16

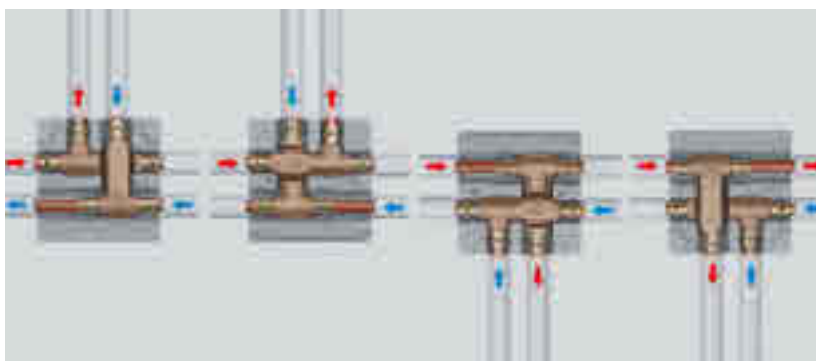

Fig. H – 17

When turning the Crossover-tee pay attention to the outlets for supply and backflow.

Bare pipes and press connection should be isolated and protected from external mechanical influences.

**Crossover-tee**

With copper piping out of the floor

**Crossover-tees**

In the storey manifold

**Crossover-tee**

Fastening the pipes in connection with cross-t-piece

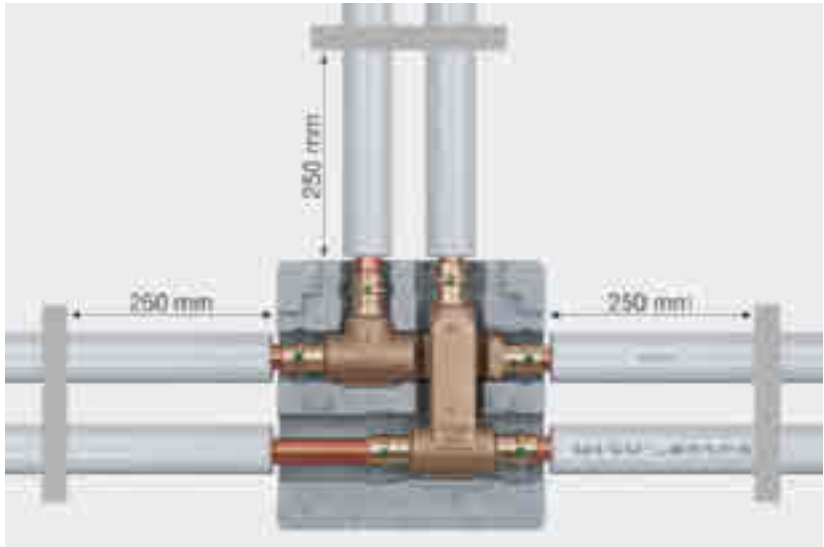

Fig. H – 18

**Assembly tip**

The following should be observed when laying pipes,

- The installation is tension-free.
- The pipes will not touch each other or cause damage due to thermal expansion.
- Gliding pipe fasteners being used do not restrict the pipes when they change length.
- Pipe fasteners do not become fixing points by mistake.

**Crossover-tee**

With two-piece insulating box



Fig. H – 19

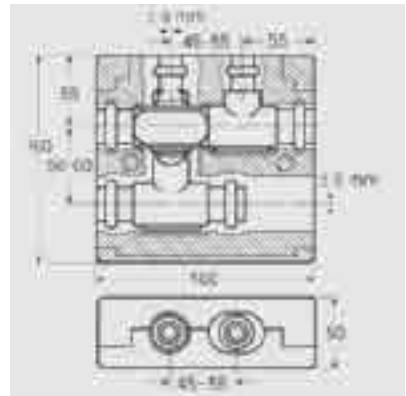

Fig. H – 20

With Tee-installation

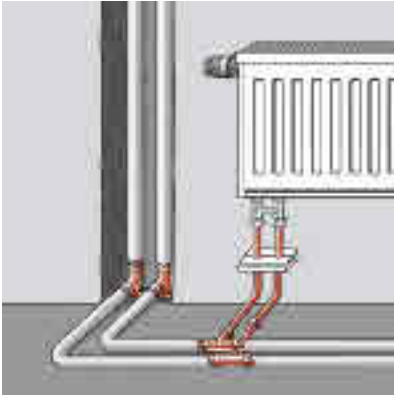

Fig. H – 21

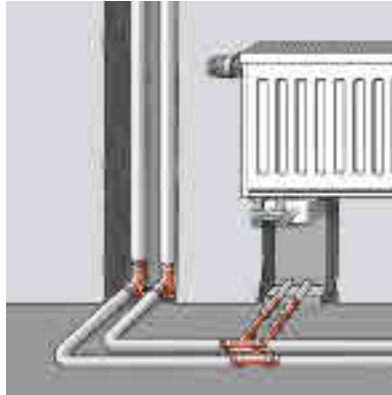

Fig. H – 22

Connection with Radiator connection block

Radiator with Radiator connection set and adapter set (for valve radiators with male or female thread). The Radiator connection block is installed in the wall, connected with copper pipes, laid in the equalising layer in the screed construction.

If the screed construction height is more than 90 mm then we recommend the Radiator connection block with a construction height of 225 mm.

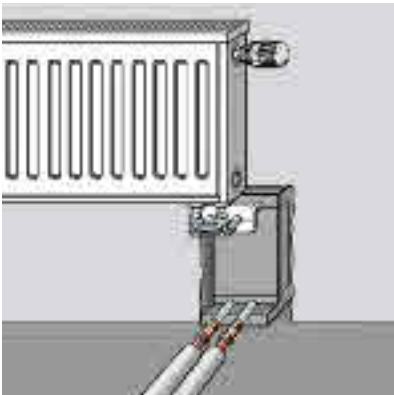

Fig. H – 23

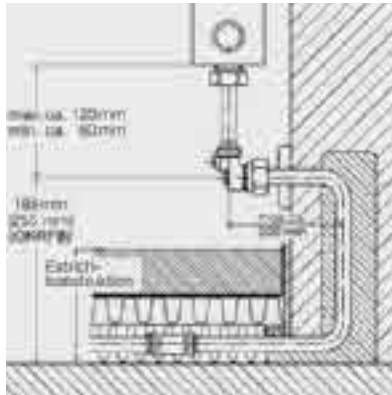

Fig. H – 24

**Tee-installation**

Connection through the floor and via the radiator connection block out of the wall

**Assembly situation**

**Advantages at a glance**

**Advantages of assembling the Radiator connection block**

- Pre-fabricated connection intervals of 50mm
- Radiator fitting after all plastering, screed and paintwork is completed.
- No extra work due to repeated assembly and disassembly of the radiator
- No damage to the radiator and connecting pipes during construction work
- No need for temporary storage, no damage to the radiator all the way to the final assembly
- No extra bleeding of the heating system necessary
- Leak test and test heating with radiator assembly (Winter mode)
- Low construction depth in the bare wall
- Colour co-ordination between stainless steel and galvanised steel radiator connection piece

**Radiator connection block**

Installation dimensions



Fig. H – 25



Fig. H – 26

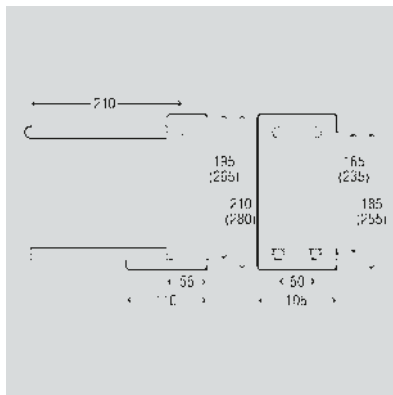

Fig. H – 27

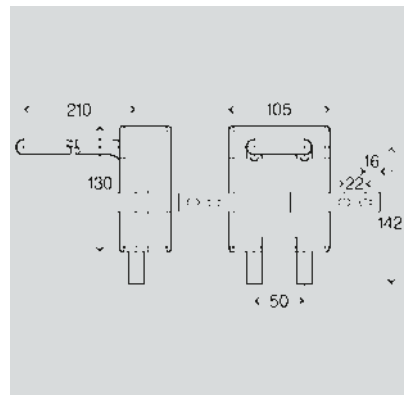

Fig. H – 28

With Baseboard radiator connection



Fig. H – 29

**Baseboard radiator connection with compact radiator**

Interchangeable, with radiator connection out of the skirting board

Also suitable for valve radiators

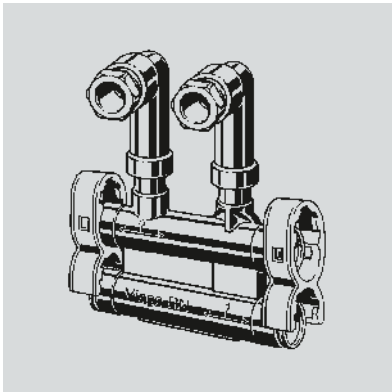

Fig. H – 30

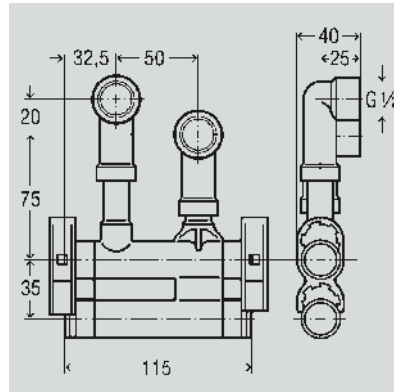

Fig. H – 31

**Baseboard radiator connection**

Assembly dimensions

- For standard skirting boards
- Optically attractive, with connection pieces made of nickel plated gunmetal
- For all standard radiator-variations
- No fire prevention measures necessary.



### Adapter sets for valve radiators

Adapter sets

Valve radiator		G ¾	Rp ½
Radiator connection pieces/sets		Adapter set model	Adapter set model
		 1022.5	 1022.6
		 1096.9	 1096.8

Tab. H – 4

Required adapter set and valve radiator connection piece for radiator with male and female thread.

### Insulation and laying of pipe systems\*

Depending on the application and pipe material, the insulation, laying and fastening of the pipes according to the technical regulations is necessary for the following reasons

- Protection against the build up of condensation
- Prevention of external corrosion
- Limitation of heat loss
- Prevention of noise due to elongation
- No transfer of flowing noises

Pipes, if not already coated or insulated in the factory, should be protected against external corrosion, irrelevant of heat insulation requirements and should be insulated against the transfer of flowing noises, as should all moulded and connection pieces. When laying the pipes, they should be fastened in such a way that elongation due to heat should not cause any noises which could disturb the user.

If piping systems are laid on a supporting surface they must be fastened. When fitting the insulating layer, at least the footfall insulation, it is necessary to obtain an even surface. For levelling above the piping system only secured filler should be used.

### Insulation against heat loss\*

To limit the heat loss in pipe systems for heat distribution they should be insulated.



Fig. H – 32

### Copper pipes

SANCO<sup>®</sup>-pipe, blank

WICU<sup>®</sup>-pipe,  
factory fitted insulation

**Exceptions to the insulating regulations**
**Heat distributing systems**

Heating piping systems are regarded as heating distributing systems and have to be insulated to reduce heat loss according to EnEV, Appendix 5 General advice for floor laid piping systems

- pipes in floors between heated rooms, even those from different owners, need to be insulated with only 9 mm – based on  $\lambda = 0.04 \text{ W/mK}$ .
- If pipes from central heating from lines 1 – 4 in heated rooms or in areas between heated rooms of one owner and their heat emission can be controlled via freely accessible shut-off valves then there are no requirements for the minimum thickness of the insulating layer.

**Minimum insulation layer thicknesses**

	Type of pipe/fitting	Minimum insulating layer thickness based on a heat conductivity of $0.035 \text{ W/(m}\cdot\text{K)}$
1	Internal diameter up to 22 mm	20 mm
2	Internal diameter over 22 up to 35 mm	30 mm
3	Internal diameter over 35 up to 100 mm	Equal to internal diameter
4	Internal diameter over 100 mm	100 mm
5	Pipes and fittings according to lines 1 to 4 in walls and ceiling openings, pipe crossings, at piping system connection points, at piping system network manifolds	1/2 the requirement from lines 1 to 4
6	Piping systems from central heating according to lines 1 to 4, which were fitted between heated rooms with different users after this ordinance came into effect	1/2 the requirement from lines 1 to 4
7	Piping systems according to line 6 in floor construction	6 mm
8	Cooling distribution and cold water pipes, as well as from room air technology and air cooling systems	6 mm

Tab. H – 5

### Pipes in floors

Tab. H-4 refers to minimum insulation layer thicknesses based on a conductivity of the insulation material of  $0.035 \text{ W/mK}$ . If an insulating material is used which is not in the WLG 035 group the minimal thickness of the insulation layer must be recalculated. In this example we use WICU-extra pipes, which are factory insulated pipes whose insulating material has a heat conductivity of  $0.025 \text{ W/mK}$ . This leads to a minimising of the total outer diameter which allows minimal floor construction heights.

### Examples

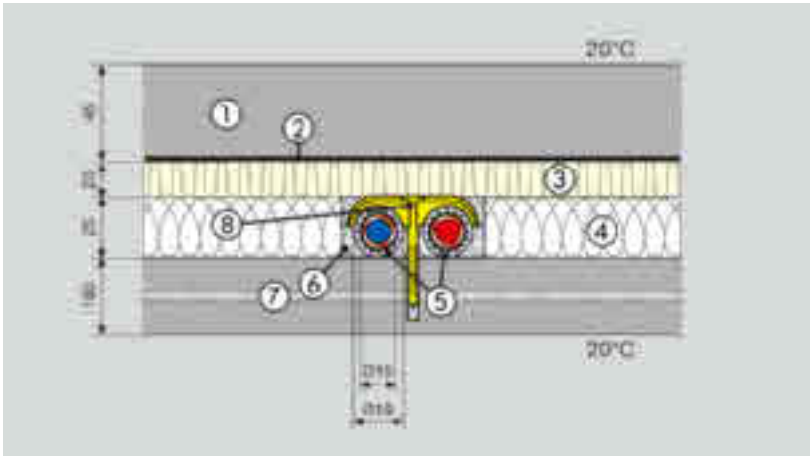

Fig. H – 33

- |  |                             |
|--|-----------------------------|
| ① Cement screed                                      | ⑤ Pipes, coated             |
| ② PE-Foil  | ⑥ Filling (Meabite/Perlite) |
| ③ Footfall insulation                                | ⑦ Concrete ceiling          |
| ④ Leveling layer WLG 040<br>(e.g. polystyrene tiles) | ⑧ Pipe fastener (Nylon)     |

### Insulating of pipes in the floor

Copper 15 mm, plastic coated, in ceiling between heated rooms belonging to one owner

>>

**Insulation of piping systems in the floor**

Copper pipe, 50%, 15 mm, with factory fitted surrounding insulation ( $\lambda = 0.026 \text{ W/mK}$ ), in closed ceiling between heated rooms from different users

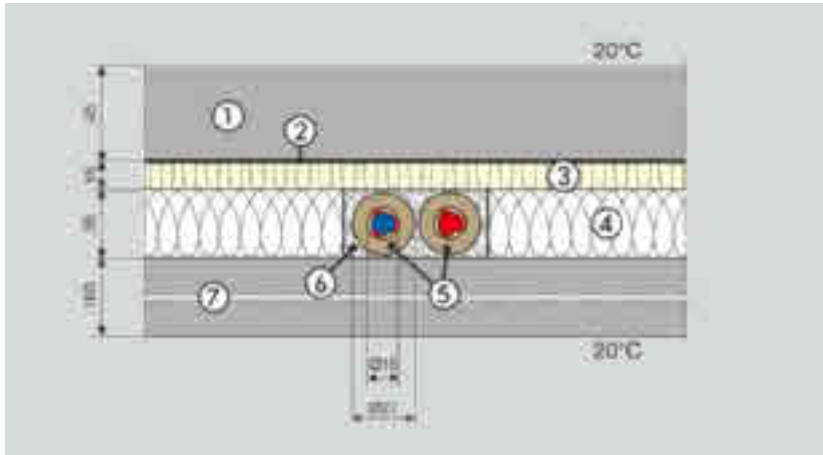

Fig. H – 34

- |  |                             |
|--|-----------------------------|
| ① Cement screed                                      | ⑤ Factory fitted insulation |
| ② PE-Foil  | ⑥ Filling (Meabite/Perlite) |
| ③ Footfall insulation                                | ⑦ Concrete ceiling          |
| ④ Leveling layer WLG 040<br>(e.g. polystyrene tiles) |                             |

**Insulation of piping systems in the floor**

Copper pipe, 50%, 15 mm, with factory fitted surrounding insulation ( $\lambda = 0.026 \text{ W/mK}$ ), in the floor against the earth, outside air or unheated rooms

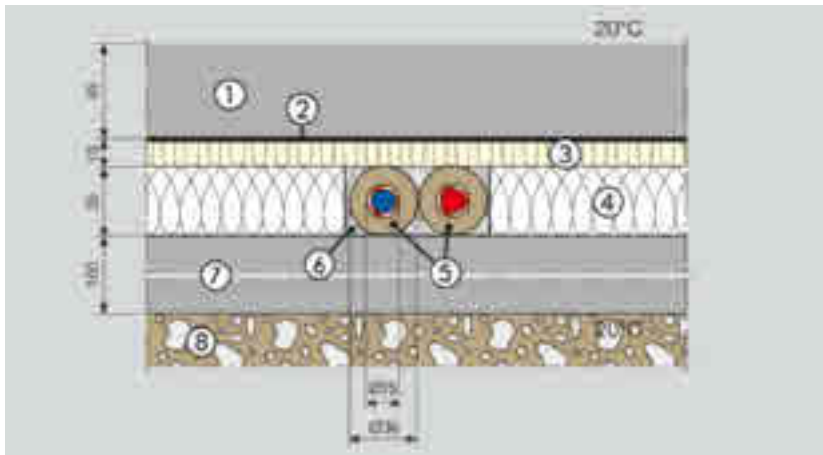

Fig. H – 35

- |  |                             |
|--|-----------------------------|
| ① Cement screed                                      | ⑤ Factory fitted insulation |
| ② PE-Foil  | ⑥ Filling (Meabite/Perlite) |
| ③ Footfall insulation                                | ⑦ Concrete ceiling          |
| ④ Leveling layer WLG 040<br>(e.g. polystyrene tiles) | ⑧ Ground (broken stones)    |

**Mixed installations**

Because during the heating of the unit nearly the entire oxygen content is thermally removed from the system, the Profipress system can be mixed with other pipes and components of other metallic materials without risk of corrosion.

An undue oxygen intake in the heating water must be prevented via competent construction of the heating system, secured fittings and installation of the compensating tank (MAG).

If an oxygen build up in the system cannot be safely prevented the technical standard VDI 2035 gives further information on how to continue, for example, the chemical binding of oxygen.

**Leakage test****With water**

All pipes should be tested in a finished condition although not yet covered with a leakage test

The system will be tested with a pressure equal to the response pressure the safety valve.

**With air**

The leakage test of the Profipress-System in heating systems can also be carried out with pressurised air or inert gases.

### District heating systems

Profipress can be used in district heating systems

EPDM sealing elements (Standard sealing elements)

- Maximum safe operating temperature 110 °C
- Maximum operating pressure 10 bar

FKM sealing elements (special accessory)/Profipress S system

- Maximum operating temperature 140 °C
- Maximum operating pressure 16 bar

#### FKM-Sealing elements

Press system	Profipress
Name	Fluor-Elastomer
Area of use	Solar systems Vacuum pipes District heating systems
Colour	black, matt
Sizes	DN 10 – DN 100

Tab. H – 6

#### Order data

Dimensions	Article-No.	Pieces/ Unit size
12 x 2.35	459376	10
15 x 2.50	459390	
18 x 2.50	459406	
22 x 3.00	459413	
28 x 3.00	459420	
35 x 3.00	459437	
42 x 4.00	459444	
54 x 4.00	459451	5
76.1 x 5.0	459468	
88.9 x 5.0	459475	
108.0 x 5.0	459482	

Tab. H – 7

### District heating transfer station

With external warm water storage



Fig. H – 36

If additives are present in the district heating water, e.g. corrosion or frost prevention solutions, Profipress can only be used with permission from Viega Service Center.

## Profipress S – System description

### Intended use

ProfipressS-press connectors are suitable for use in heating systems with temperatures of over 100 °C and short term peak temperatures of over 280 °C together with copper pipes in accordance with DIN EN 1057.

- Solar systems
- District heating systems
- Low pressure steam systems

Use with Profipress-press connectors is allowed, if it retrofitted with FKM sealing elements (12 - 35mm).

The use of the system in plants with additives (e.g. anti-corrosion or anti-freeze solutions) in the heating water or for other uses other than those described must be approved by Viega Service Center.

### Operating conditions for district heating systems

- Operating pressure  $p_{\max} \leq 16 \text{ bar}$
- Operating temperature  $T_{\max} \leq 140 \text{ °C}$

### Operating conditions for low pressure steam systems

- Operating pressure  $p_{\max} < 1 \text{ bar}$
- Operating temperature  $T_{\max} \leq 120 \text{ °C}$

### Marking

- White dot on the SC-Contur crimp.
- White square with FKM ID mark.

Use of Profipress S- and Profipress-press connectors with FKM sealing elements is not permitted in drinking water and gas installations.



Fig. H – 37



Fig. H – 38

### Marking

Profipress S

Orange coloured packaging



## Application technology

### Piping system

- The supply is with rising gradient, the backflow with falling gradient, therefore allowing the system to be emptied if required.
- When emptying the system the heat transfer medium must be collected in a container.
- When laying the collector piping system the maximum expected thermal elongation should be taken into account.

Example of thermal elongation: If the length of a pipe at an average temperature of 15 °C is 15m then the pipe expands by roughly 21 mm at an average temperature of 100 °C.

### Pipe material

For use in solar thermic systems, copper pipes with low wall strengths, which conform to EN 1057, can be used with Profipress (See minimum wallthickness acc. to *Tab. H-1*).

Warning with pre-insulated pipes!

The maximum operating temperature of the insulating material is normally only 100 °C.

Refer to the manufacturer's documentation.

### Flushing

The simple flushing process is adequate to flush the system with Profipress that means with water and normal pressure. The whole collector system is flushed including solar thermic unit, collector and storage all in flow direction of the pump.

To prevent boiling or freezing of the flushing liquid the unit should not be flushed at extremely high or low external temperatures.

### Pressure test

The pressure test is to be carried out according to the documentation of the individual collector manufacturer.

Attention: detailed information for the assembly of solar thermic units can be obtained, for example, from the Deutsches Kupfer Institut.

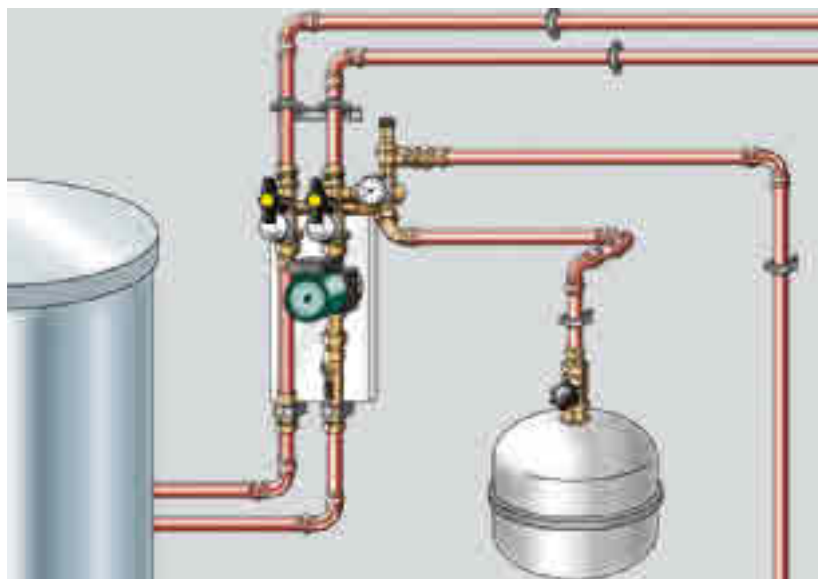

**Solar thermic system**  
Domestic connection

*Fig. H – 39*

## Steel piping systems

### Prestabo – System description

#### Intended use

The Prestabo-system is designed for use in industrial and heating units and not suitable for use in drinking water installations. Pipes and connectors are therefore marked with a red symbol »not for drinking water installations«.

Prestabo-components may only be used with components that belong to the system. Use of the system for applications other than those described is only permitted with permission from Viega Service Center.

The press connectors come with SC-Contur and a visibly leaky in an unpressed condition.

#### Conditions of use when applied with EPDM sealing elements

- Water, closed system: Operating temperature  $T_{\max} = 110^{\circ}\text{C}$ ;  
 $p_{\max} \leq 16 \text{ bar}$
- Pressurised air, dry and oil free:  $p_{\max} \leq 16 \text{ bar}$

#### Conditions of use with FKM sealing element

- Water: Operating temperature  $T_{\max} = 140^{\circ}\text{C}$ ;  $p_{\max} \leq 16 \text{ bar}$
- High pressure air, dry but contains oil:  $p_{\max} \leq 16 \text{ bar}$

#### Prestabo- pipes, press connec- tors and flanges

With red marking »Not  
suitable for drinking  
water installations«



Fig. H – 40



Fig. H – 41

### Technical data

Non-alloyed steel material no 1.0308 according to EN10305-3, externally galvanized. Pipe sizes 15 to 54 mm also available with 1.0 mm PP coating.

Factory fitted EPDM sealing element as O-ring for operating temperatures  $\leq 110^{\circ}\text{C}$  and operating pressure up to 16 bar.

6 m lengths, tested against leakage and marked as such

12/15/18/22/28/35/42/54

64.0/76.1/88.9/108.0

- Solar thermic systems (PP coated pipe excluded)
- Air-conditioning units
- Heating systems
- Pressurised air systems
- Vacuum systems
- Systems for technical gases (on request)

#### Pipe statistics Prestabo-pipe, blank

Pipe $\varnothing_{\text{external}} \times s$ [mm]	Volume per metre [Liter/m]	Weight per metre [kg/m]	Weight per 6 m length [kg]	Article-No.
12 x 1.2	0.07	0.32	1.9	650339
15 x 1.2	0.13	0.41	2.5	559441
18 x 1.2	0.19	0.50	3.0	559458
22 x 1.5	0.28	0.80	4.6	559465
28 x 1.5	0.49	1.00	5.9	559472
35 x 1.5	0.80	1.20	7.4	559496
42 x 1.5	1.19	1.50	9.0	559489
54 x 1.5	2.04	2.00	11.7	559502
64.0 x 2.0	2.83	3.06	18.3	598327
76.1 x 2.0	4.08	3.66	21.9	598334
88.9 x 2.0	5.66	4.29	25.7	598341
108.0 x 2.0	8.49	5.23	31.4	598358

#### Pipe statistics Prestabo-pipe, coated

17 x 2.2	0.13	0.45	2.7	577117
20 x 2.2	0.19	0.60	3.3	577124
24 x 2.5	0.28	0.82	4.9	577131
30 x 2.5	0.49	1.10	6.4	577148
37 x 2.5	0.80	1.30	8.1	577551
44 x 2.5	1.19	1.60	9.7	577568
56 x 2.5	2.04	2.10	12.6	577575

Tab. H – 8

**Pipe and Press-connector material**

**Sealing element**

**Delivery condition  
Nominal sizes [mm]**

Prestabo

Prestabo XL

**Areas of use**

**Pipe statistics**

Blank pipe

**Pipe statistics**

Dimensions incl.  
1.0 mm PP-coating

## Components

### Pipes

Prestabo steel pipes are thin-walled, lengthwise welded pipes made of non-alloyed steel Material no 1.0308 according to EN 10305-3 externally galvanized with a zinc layer thickness of 8 to 15  $\mu\text{m}$  (blue chromatised). They are stable with low heat expansion and therefore ideal for cellar and risers in heating installations.

### Pipe sizes

- Blank – all sizes: For concealed installations, cellars and riser pipes. Heat carrying pipes will be insulated retrospectively.
- Coated 15 – 54 mm with PP coating optically attractive visible installations.
- Pipe lengths of 6 m with metallic blank outer and inner surface.
- The pipe ends are closed with red plastic caps to prevent contamination.
- All pipes are tested for leakage.

### Pipe sizes

### Marking

Not suitable for drinking water (also refer to next page)

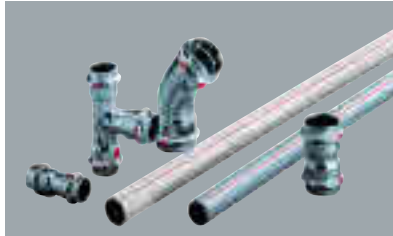

Fig. H – 42

### Pipe markings



Fig. H – 43

- |                                   |                                    |
|-----------------------------------|------------------------------------|
| ① System manufacturer/system name | ⑤ Abbreviation of pipe manufacture |
| ② Material No.                    | ⑥ Date of manufacture              |
| ③ Coating material                | ⑦ Charge number                    |
| ④ Nominal width x wall thickness  |                                    |

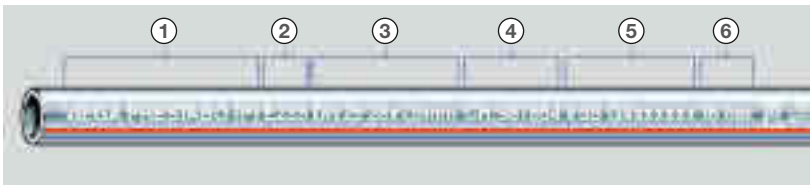

Fig. H – 44

- |                                   |                                |
|-----------------------------------|--------------------------------|
| ① System manufacturer/system name | ④ charge number                |
| ② Material No.                    | ⑤ Certification symbol/-number |
| ③ Nominal width x wall thickness  | ⑥ Pressure level               |

### Storage and transportation

To ensure the uncompromised quality of the Prestabo steel pipes, the following guidelines must be taken into account when transporting and storing pipes

- Packaging and protective films (only for pipes wrapped in PP film) shall only be removed shortly before use.
- The pipe ends must be closed with end caps when delivered before use.
- Do not store the pipes on the concrete floor without protection.
- Do not stick protective foils or similar to pipes.
- Do not pull pipes over loading sills.
- Only use a steel cleaning agent to clean the surfaces of pipes.

### Pipe markings

Blank and coated pipe

#### Attention!

»Not suitable for drinking water installations!«



### Pipe marking

Sendzimir galvanised pipe.

### Press connectors

All press connectors are made non-alloyed steel material no 1.0308 according EN 10305-3, externally galvanized with a zinc coating of 8 – 15 µm (blue chromatised).

### SC-Contur

The SC-Contur flags up non-pressed press connectors when the system is filling up. Non-pressed press connectors, indicated by water leaking or the pressure reading on the test gauge, can be detected reliably at pressures from 1 bar to 6.5 bar and pressed immediately.

#### Prestabo

Press connection system with SC-Contur

Connector  
15 – 108.0mm made  
of non-alloy steel,  
externally galvanized

Factory fitted with  
EPDM-sealing element



Fig. H – 45

### Technical characteristics

- SC-Contur – red marking on the crimp
- Precise insertion zone, in diameter, length and straightness
- Pre-determined insertion depth through moulded stopper
- Factory fitted sealing element made of EPDM
- The volume of the press sleeve crimp made exactly for the sealing element
- In accordance with the recognised engineering standards
- Extensive fitting range
- Viega-Press machines – battery or mains operated – for the economical one man assembly

## Sealing elements

### EPDM

Prestabo-Press connectors are factory fitted with EPDM sealing elements, which are adequate for most applications. Some typical applications are listed in the following table.

#### Prestabo-application with EPDM-sealing element

Field of application	Application range	T <sub>max</sub> [°C]	P <sub>max</sub> [bar]	comments
Heating	Pump hot water heating 95 °C Radiator connection	max. 105	–	EN 12828
Solar thermic systems	Solar circuit	–	6	for flat collectors
Air-conditioning units	Secondary circuit closed	–	10	Inhibitors for cold water sets, see material constitution
Pressurised air	Whole piping system	20	16	Dry, max. oil concentration 25 mg/m <sup>3</sup>
Vacuum	Whole piping system	20	1.0 mbar	
Technical gases	Whole piping system	20	–	Feedback required!

Tab. H – 9

### FKM

For application areas with higher temperatures and pressure, press connectors can be fitted with an FKM sealing element.

The factory fitted EPDM sealing element can be exchanged for the FKM sealing element. Examples in the following table.

#### Prestabo-areas of use with FKM-sealing elements

Area of use	Application	T <sub>max</sub> [°C]	P <sub>max</sub> [bar]	Comments
District heating	District heating after house connection	140	16	
Steam	Low pressure steam systems	120	<1	
Solar thermic systems	Solar circuits	–	6	For vacuum collectors

Tab. H – 10

#### Order Data FKM-sealing elements

Sizes [mm]	Art.-No.	Sizes [mm]	Art.-No.
12 x 2.35	459376	42 x 4.13	459444
15 x 2.60	459390	54 x 4.13	459451
18 x 2.60	459406	64.0 x 5	614461
22 x 3.10	459413	76.1 x 5	614485
28 x 3.10	459420	88.9 x 5	614478
35 x 3.25	459437	108.0 x 5	614492

Tab. H – 11



FKM-Sealing elements must not be used in drinking water and gas installations.



## Application technology

### Additional corrosion protection necessary for corrosive building materials

E.g.: Levelling screeds, fillers, etc.

### Thermal insulation should be considered as a separate issue!

### Protection from external corrosion

Prestabo pipes and connectors are protected by an external galvanisation. Nevertheless, additional protective measures are needed against long-term moisture or in case of contact with corrosive building materials.

- Use of closed-cell insulation tubes with professional sealing of all abutting and cut edges using a suitable filler.
- Check separating foil in floor constructions for complete impermeability.
- Installation outside of areas at risk of moisture.
- Visible radiator connections rising from the floors should be avoided if floors will be cleaned frequently with water and/or cleaning agents/disinfectants, for example in retirement homes and care homes. Wall connections make cleaning easier and also exclude any additional risks of corrosion.
- If the radiator connections do come from the floor, professional corrosion protection and professional sealing of the joints must be ensured in order to rule out any risk of corrosion caused by penetrating cleaning water.
- Use of covered pipes (Prestabo) – Other pipe qualities must be protected additionally against corrosion in accordance with the manufacturer's instructions.

As a basic principle, connecting radiators from the wall, professional sealing joints and using covered pipes are the best measures to avoid corrosion.

If, despite the above measures, no permanent protection against moisture can be guaranteed or if the areas of use have particular requirements - e.g. in cooling circuits - then special corrosion protection measures must be taken and checked in each individual case. The manufacturer information of the products used along with the AGI Worksheet Q 151 must be heeded for these measures.

Irrespective of corrosion protection, the location of thermal insulation must be checked in each individual case.

### Industrial use

For installations within the industrial area, with contamination caused by aggressive ambient air, the pertinent internal factory standards must also be taken into consideration. If pipes are installed in components of bathrooms, industrial kitchens and butchers' shops that are continually subject to moist conditions, then the following protective measures have proven themselves to be effective

- Use of closed-cell insulation tubes, with careful sealing of all abutting and cut edges using a suitable filler.
- Waterproofing of the installed pipes using separating foil in floor constructions.
- Installation of pipes away from the areas at risk.

### Cooling water circuits

The Viega Prestabo press connector system can be used in all closed cooling water circuits, in which it is not possible for oxygen to enter during operation.

Due to the operating conditions in cooling water systems, it can be necessary to equip the carrier medium with an anti-freeze agent. If the glycol proportion of the total water content is less than 50%, standard EPDM sealing elements can be used. Viega sendzimir galvanised pipes are not suitable for this use.

According to DIN EN 14868 (2005-11), the refilling of a system does not normally lead to significant oxygenation. However, the oxygenation can lead to system damage (corrosion) if the circulation water in the system is regularly topped up as the result of losses or - e.g. through automatic dosing - considerable amounts of fresh water are added.

Following the VDI Guideline 2035 Tab. 1, the oxygen content of low-salt water should be less than 0.1 mg/l. For salty water, this should be less than 0.02 mg/l.

### Protection from internal corrosion (three-phase limit)

When it comes to metallic materials, corrosion can occur in the region of the three-phase limit of water, material and air. This corrosion can be avoided if the system remains completely full of water after the first filling and ventilation procedure. If the system is not commissioned immediately after installation, we recommend a pressure and leakage test with air or inert gases.

### Insulation and installation\*

Depending on the use and pipe material, the insulation, installation and attachment of pipes must be carried out in accordance with the recognised rules of technology for the following reasons

- Protection from the build-up of condensation
- Avoidance of external corrosion
- Limiting of heat losses
- Avoidance of cracking sounds due to thermal expansion
- No transfer of flow noise

Blank Prestabo pipes and all forms and connecting parts must be insulated against external corrosion and from the transmission of flow noises on-site - irrespective of the insulation requirements of the EnEV.

During installation, pipes must be attached in such a way that operation-related elongations do not cause any cracking sounds, which can severely reduce the comfort of the user.

If the installation is fed through fire compartments, the product information of the insulation manufacturer must be taken into consideration for the heating pipes

**Addition of glycol**

**Permitted oxygen content**

**The EnEV (Energy Saving Regulation) requirements apply.**

**Insulation against heat losses**

To limit heat transfer from the pipes to the heat distribution, we recommend insulating these in accordance with EnEV, Appendix 5. National regulations must be taken into consideration.

Examples with pipes installed in the floor

**Example:**

**Insulation of pipes in floor constructions**

Prestabo pipe 15 mm, with Exzentroflex insulation (h = 38 mm) as radiator connector in the ceiling between the heated rooms of various users

EnEV, Appendix 5, Table 1, Line 7

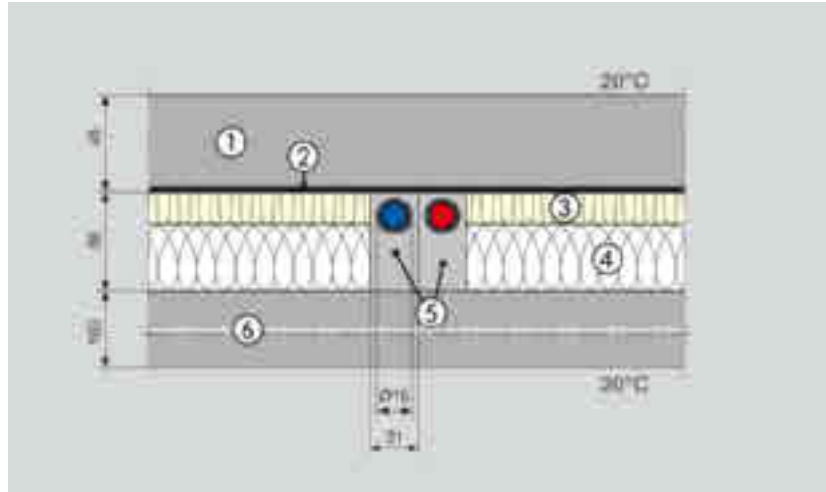

Fig. H – 46

**Example:**

**Insulation of pipes in floor constructions**

Prestabo pipe 15 mm, with Exzentroflex insulation (h = 59 mm) as radiator connector, in the floor structure against soil, external air and unheated rooms

EnEV, Appendix 5, Table 1, Line 1

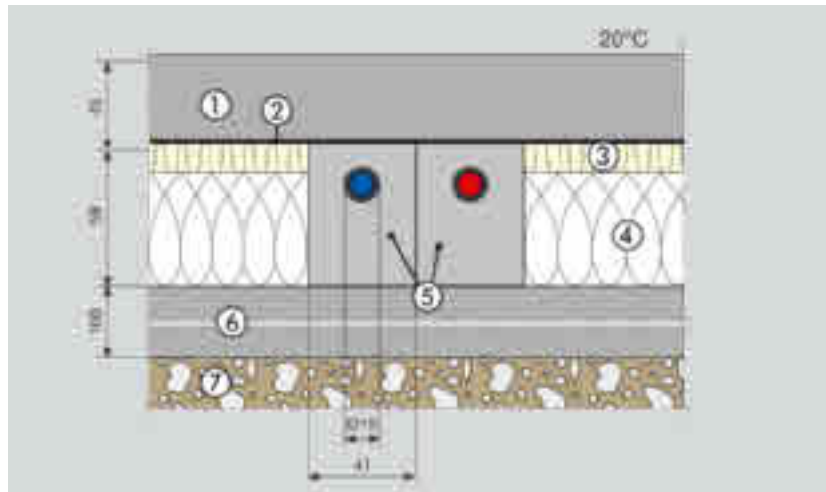

Fig. H – 47

- ① Cement screed
- ② PE film
- ③ Impact sound insulation
- ④ WLG 040 compensating layer
- ⑤ Thermal insulation pipe
- ⑥ Raw ceiling
- ⑦ Soil (gravel)

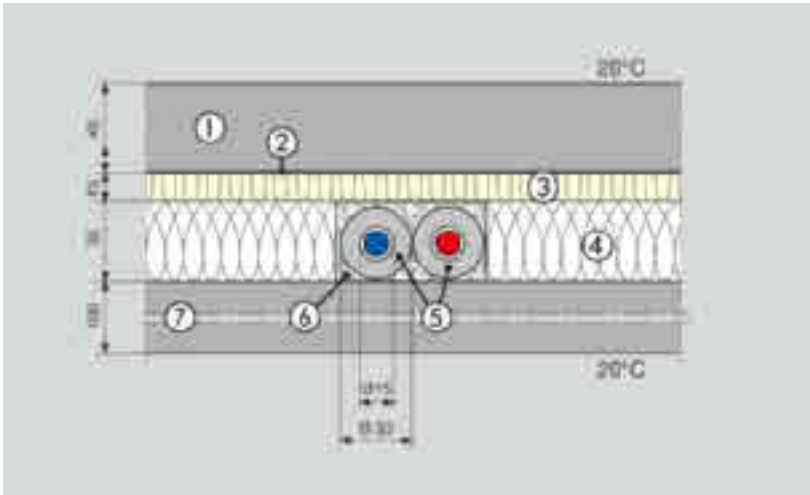

Fig. H – 48

**Example:**
**Insulation of pipes in floor constructions**

Prestabo pipe 15 mm, with 9 mm surrounding insulation ( $\lambda = 0.04 \text{ W/m.K}$ ) in the ceiling between the heated rooms of various users

EnEV, Appendix 5, Table 1, Line 7

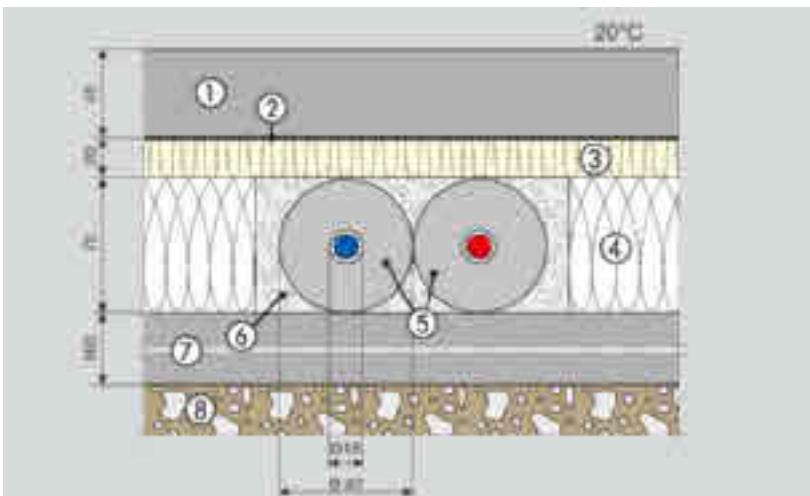

Fig. H – 49

**Example:**
**Insulation of pipes in floor constructions**

Prestabo pipe 15 mm, with 26 mm surrounding insulation ( $\lambda = 0.04 \text{ W/m.K}$ ) against soil, external air or unheated rooms

EnEV, Appendix 5, Table 1, Line 1

- |                              |                               |
|------------------------------|-------------------------------|
| ① Cement screed              | ⑤ Thermal insulation pipe     |
| ② PE film                    | ⑥ Ballast (Meabitt / perlite) |
| ③ Impact sound insulation    | ⑦ Raw ceiling                 |
| ④ WLG 040 compensating layer | ⑧ Soil (gravel)               |

**Example:**
**Insulation of pipes in floor constructions**

Prestabo pipe 15 mm, plastic coated, in the ceilings between the heated rooms of various users

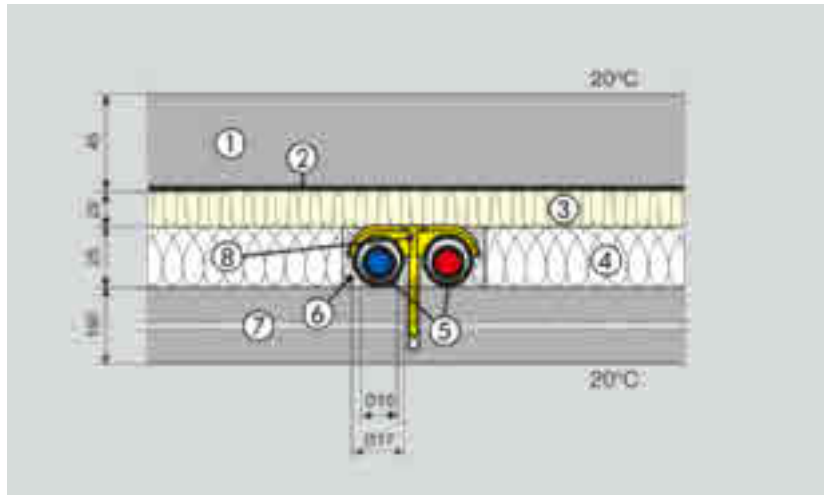

Fig. H – 50

- |                              |                              |
|------------------------------|------------------------------|
| ① Cement screed              | ⑤ Pipe (coated in PP)        |
| ② PE film                    | ⑥ Ballast (Meabit / perlite) |
| ③ Impact sound insulation    | ⑦ Raw ceiling                |
| ④ WLG 040 compensating layer | ⑧ Impact dowel (nylon)       |

**Potential equalisation\***

The Prestabo system is an electrically conductive system and must therefore be taken into account when dealing with potential equalisation. If a piping system or part of it is exchanged as part of a renovation the potential equalisation must be checked by an electrical engineer. The person who constructs the electrical system is responsible for the potential equalisation.

**Mixed installations**

The Prestabo-System can be used in conjunction with individual gunmetal components (Viega-Sanpress). Adapter from Prestabo onto system parts made of copper or stainless steel should be made with gunmetal fittings. Because during the heating of the unit nearly the entire oxygen content is thermally removed from the system, the Profipress-system can be mixed with other pipes and components of other metallic materials without risk of corrosion. An oxygen intake in the heating water must be prevented via competent construction of the heating system, secured fittings and installation of the compensating tank. If an oxygen build up in the system cannot be safely prevented the technical standard VDI 2035 gives further information on how to continue for example the chemical binding of oxygen. The mixing of entire installations is not permitted.

### Pipe fitting and fastening

For the fitting of the pipes standard pipe clamps with chloride free sound proofing inlays should be used.

The general rules of fastening technology should be observed.

- Fastened pipes may not be used as support for other pipe systems or components
- Pipe hooks may not be used
- Distance to connectors must be observed
- Expansion direction should be observed fix and gliding points should be planned

To avoid the build up of noise through vibrations fastening gaps in the table

#### Recommended fastening gaps

Pipe size [mm]	Fastening gap pipe rod [m]	Pipe size [mm]	Fastening gap pipe rod [m]
12	1.25	42	3.00
15	1.25	54	3.50
18	1.50	64.0	4.00
22	2.00	76.1	4.25
28	2.25	88.9	4.75
35	2.75	108.0	5.00

Tab. H – 12

### Elongation – compensating members

The expansion, due to heat, experienced in a piping system varies depending on the pipe material.

To avoid unwanted tension in the pipe network this should be taken into account when planning a piping system network. Special attention should be paid to the use of

- Fix- and gliding points
- Expansion compensating members like expansion bends
- Axial-compensators

The expansion  $\Delta l$  of piping systems is dependent on the following physical values

- The temperature difference  $\Delta T$  of the medium,
- from the length of the piping system  $l_0$  and
- the thermal elongation co-efficient  $\alpha$ .

$\Delta l$  can be taken from diagrams such as *Fig. H-48* or can be calculated.

#### Example

Given operating conditions

- The operating temperature is between 10 and 60 °C – there,  $\Delta T = 50 \text{ K}$
- The section of pipe is  $l_0 = 20 \text{ m}$
- The length expansion coefficient for galvanised steel pipes is  $\alpha = 0.0120 [\text{mm/mK}]$

Insert the values into the formula:  $\Delta l = \alpha [\text{mm/mK}] \cdot L [\text{m}] \cdot \Delta T [\text{K}]$

#### Result

$$\Delta l = 0.0120 [\text{mm/mK}] \cdot 20 [\text{m}] \cdot 50 [\text{K}] = 12 \text{ mm elongation}$$

Prestabo elongation

Elongation Prestabo-piping systems

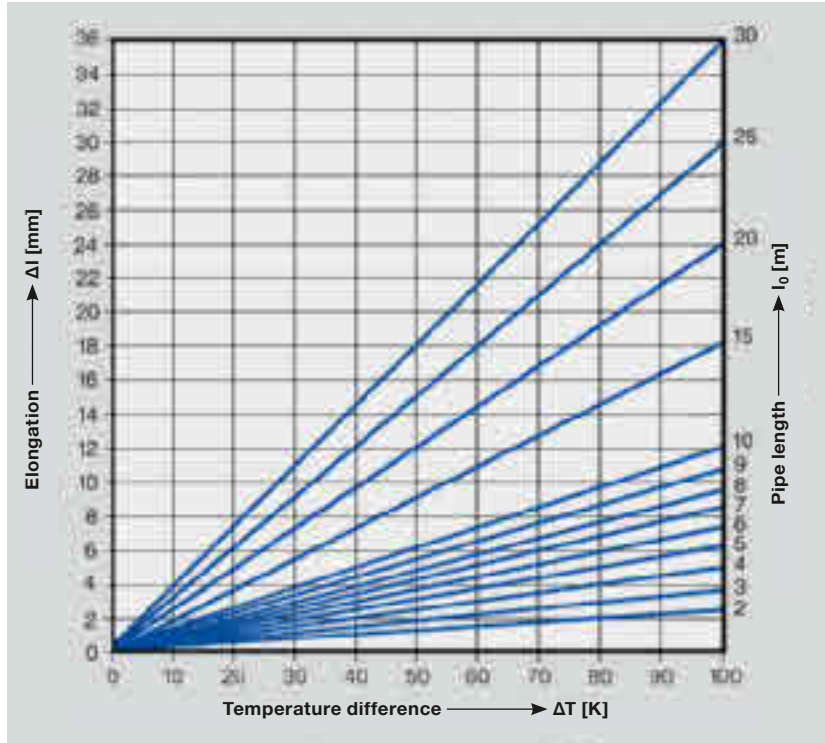

Fig. H – 51

Calculating the elongation

Follow the x-axis to find the temperature difference up to the pipe length, then on the left on the y-axis you can find the elongation value.

Elongation of various materials

	Thermal elongation co-efficient $\alpha$ [mm/mK]	Elongation pipe length = 20 m and $\Delta T = 50 K$ [mm]
Stainless steel (1.4401)	0.0165	16.5
Galvanised steel	0.0120	12.0
Copper	0.0166	16.6
Plastic	0.08 – 0.18	80 – 180

Tab. H – 13

**U- or Z-expansion compensating members – calculation**

Thermal expansions in installation systems generate stresses in pipes and appliance connectors. For this reason, compensation bends or expansion compensating members need to be fitted to long stretches of pipes. Expansion compensating members are lengths of pipe with U or Z-shaped expansion joints and are able to absorb movement and prevent damage to the piping system because of their length and fastening method.

This is done by deliberately placing the elongation movement on parts of the piping system that are flexible enough due to their length. These are called expansion bends.

Calculating the length of expansion bend required is simple.

- Determine the maximum possible temperature difference  $\Delta T$ .
- Identify the length of the pipe  $\rho l_0$ .
- These values are used to calculate the total length by which the section of pipe extends, in the example in the previous chapter,  $\Delta l = 12 \text{ mm}$ .
- The diagrams in Fig. H-52 and H-53 allows the length of expansion bends required  $L_{BZ}$  or  $L_{BU}$  to be read immediately.

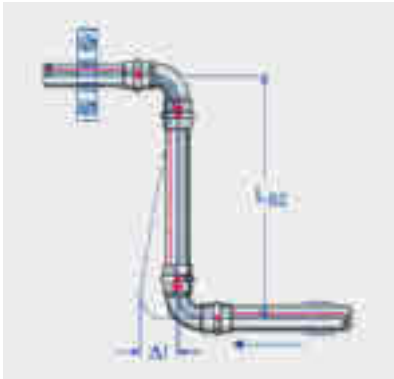

Fig. H – 52

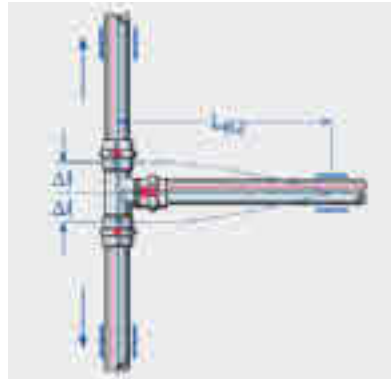

Fig. H – 53

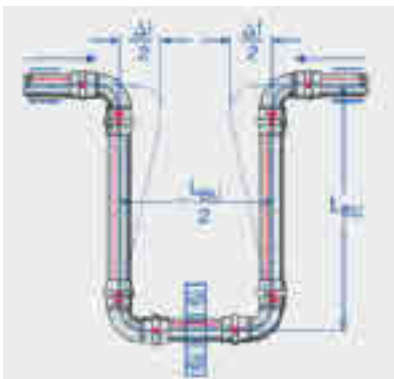

Fig. H – 54

**Calculation expansion bend**

**Expansion bend**

Z-form with expansion bend  $L_{BZ}$  and as t-connector  $\varnothing \leq 54 \text{ mm}$

**Expansion bend**

U-form with expansion  $L_{BU}$   $\varnothing \leq 54 \text{ mm}$



**Expansion bend  
Z- and t-form**

Calculation of the length of the expansion bend ( $\varnothing \leq 54 \text{ mm}$ )

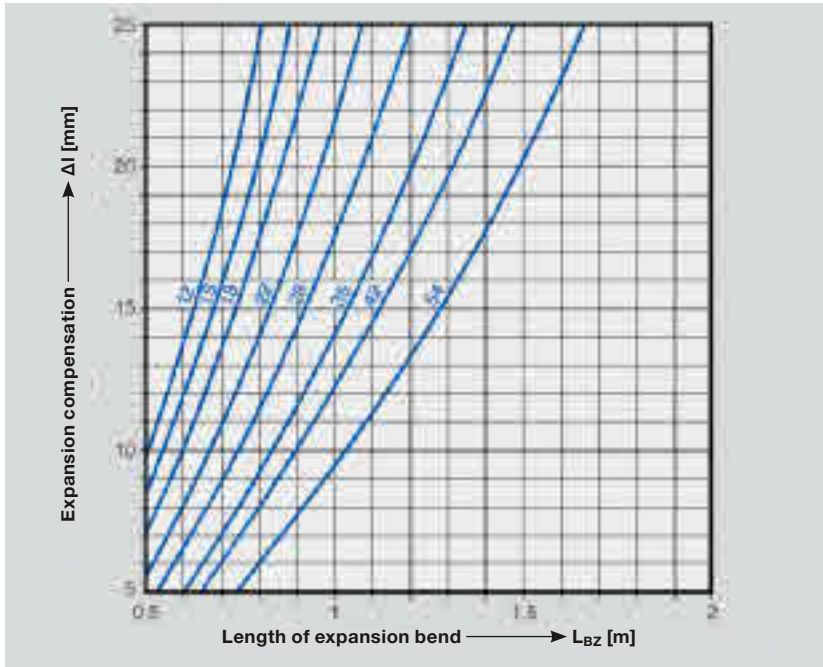

Fig. H – 55

**Expansion bend  
U-form**

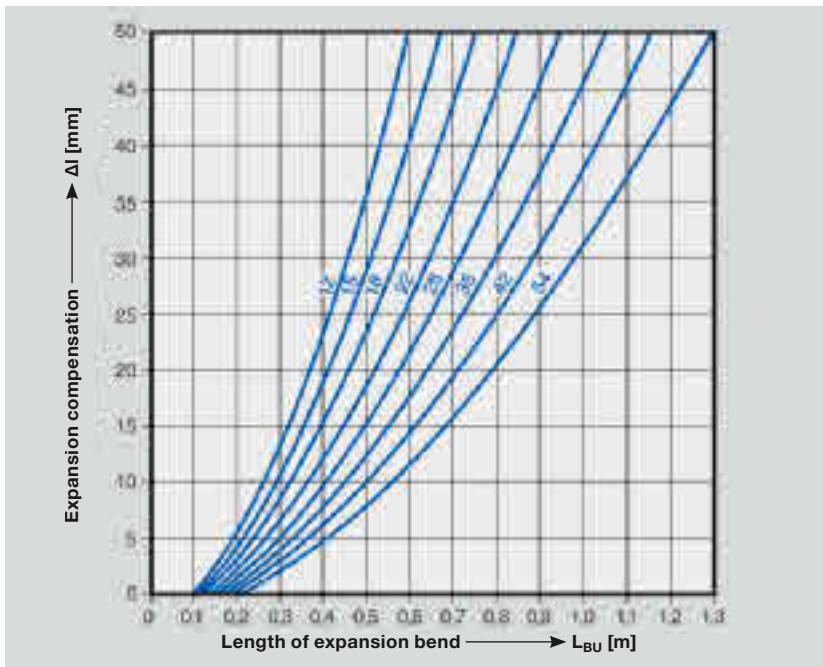

Fig. H – 56

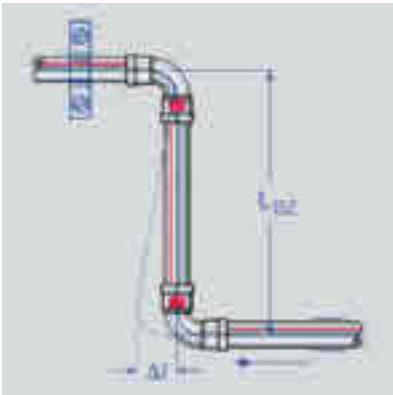

Fig. H – 57

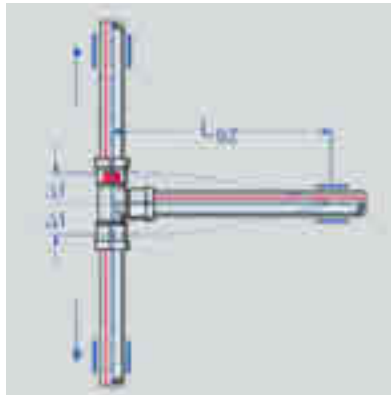

Fig. H – 58

**Expansion bend**

Z-form with expansion bend  $L_{BZ}$  and as t-connection  $\varnothing \geq 64.0\text{ mm}$

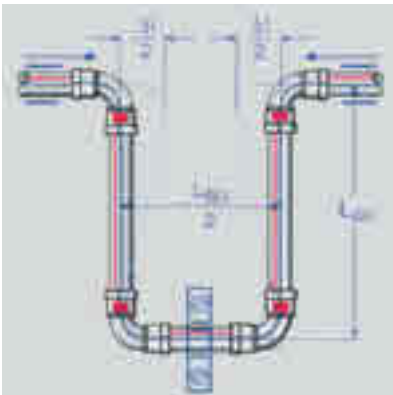

Fig. H – 59

**Expansion bend**

U-form with expansion bend  $L_{BU}$   $\varnothing \geq 64.0\text{ mm}$

**Expansion bend  
Z- and t-form**

Calculation of the length of the expansion bend ( $\varnothing \geq 64$  mm)

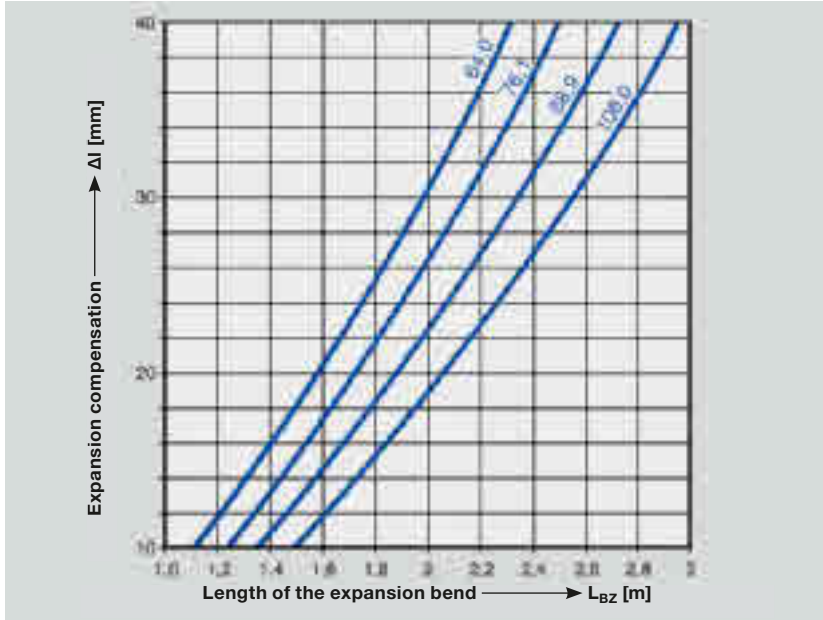

Fig. H – 60

**Expansion bend**

U-form

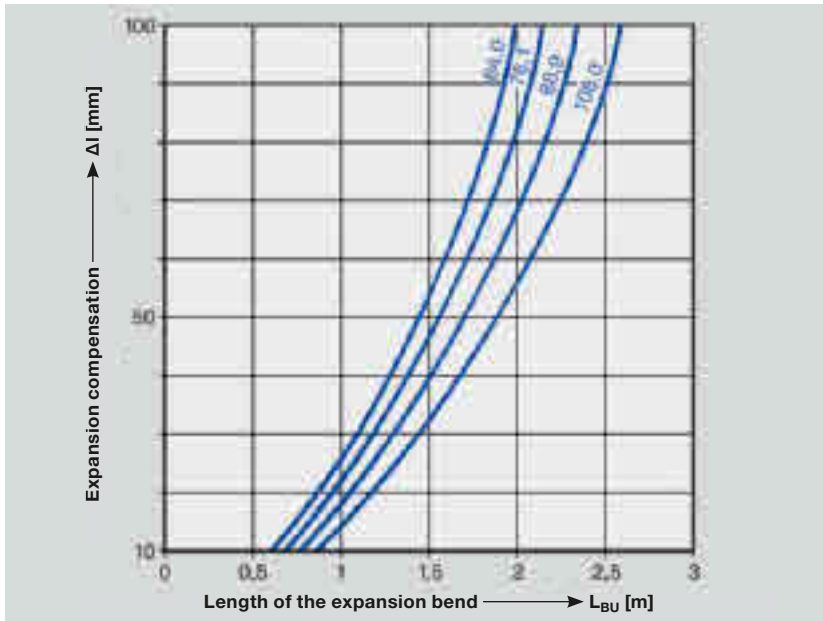

Fig. H – 61

## Assembly

### Storage and transportation

To prevent damage of the zinc layer the pipes should not be stored directly on the ground to protect against damage via transport and do not draw along the edge of the transporter.

### Preparation

#### Shortening

Blank pipes can be shortened with pipe cutters, fine tooth metal saws or automatic saws. The use of disc saws or cutting torches is not allowed.

With factory coated pipes the area for the press connectors must be removed. The use of the Prestabo dismantling tool guarantees the correct dismantling according to insertion.

Lengthways grooves on the outer surface of the pipes should be avoided.

#### Dismantling

The dismantling tool ① allows the precise removal of the plastic coating in the area of the press sleeve ②, damage to the metal surface is prevented and only removes as much material as is required for the insertion depth ③.

The use of other tools is not recommended.

**Attention:** do not sharpen blades, replace them



Fig. H – 62

#### Stripping tool

Removes exactly the required amount for the press sleeve's insertion depth

(The colour of the stripping tool may vary)

**De-burring**

The pipe ends must be de-burred both internally and externally after cutting; this prevents damage to the sealing element or canting of the press connection during assembly.

**Bending**

Prestabo pipes, blank 12, 15, 18, 22 mm can be bent cold using standard bending machines. The pipe ends must be at least 50 mm long so that the press connector can be properly fitted.

Attention: Coated Prestabo pipes should not be bent as there is currently no suitable bending tool available.

**Expansion bend**

U-form with expansion bend  $L_{BU} \varnothing \geq 64.0 \text{ mm}$



*Fig. H – 63*

### Assembly examples



Fig. H – 64



Fig. H – 65



Fig. H – 66



Fig. H – 67



Fig. H – 68

#### Heating system

Manifold installation  
with Prestabo

#### Radiator connection Easytop-ball valves

#### Press tools

Press technology in  
areas of restricted  
access

**Fastening methods – fixed and gliding points**

Pipes can be laid with fixed points or with gliding fasteners

- Fixed points are rigidly connected to the component
- Gliding points allow an axial expansion

Fixed points should be arranged, so that

- Torsion tensions due to length difference are mostly avoided
- Pipes that have no change in direction and only have a fixed point.

Gliding points should be fitted with adequate distance to connectors; at this point the expected elongation due to heating should be taken into consideration.

**Fixed points and gliding points**

Keep distance from connectors

Expansion-direction should be observed



Fig. H – 69



Fig. H – 70

**Fastening with a fixed point**

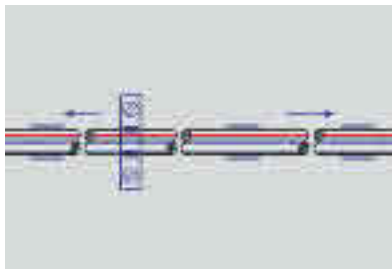

Fig. H – 71

### Concealed installation

A pre-wall pipe or a pipe in an installation shaft has enough room at its disposal for expansion. When laying concealed pipes or in screed constructions a soft installation material for example foam must be used so that this space is created, this is especially true in areas close to T-pieces and bends because mechanical forces have extra effect on these places.

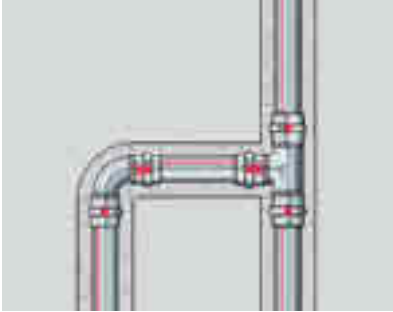

Fig. H – 72

### Laying in screed

Pipes under floating floor screed are mostly laid in the equalising layer or the footfall insulation where adequate expansion is available. The point where the pipe protrudes vertically from the screed must be created by using suitable insulating material.

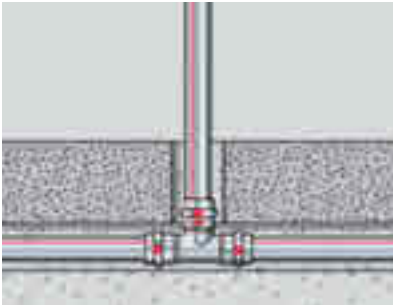

Fig. H – 73

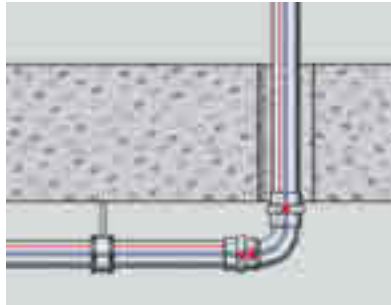

Fig. H – 74

### Concealed installation

With insulation

### Laying in the screed construction

With branch line

Floor opening



**Tar screed (mastic-asphalt)**

Professional floor construction

**Laying in tar screed – mastic asphalt**

Storey manifold with Prestabo connectors require professional installation. In underfloor heating Prestabo press connections must be protected by 20 cm of non-flammable material on each side. The system should be filled before laying the screed.

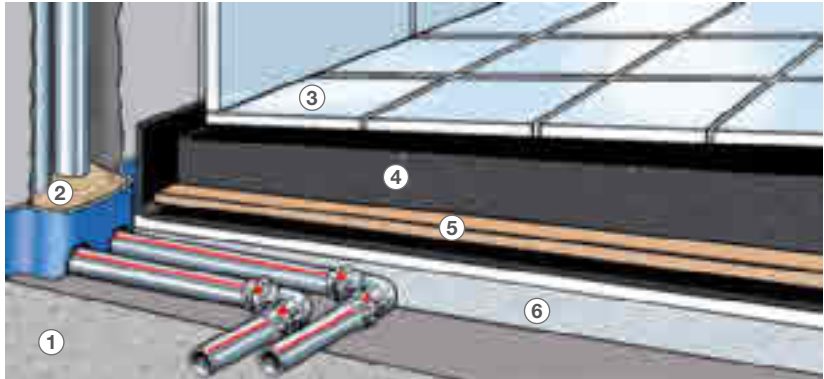

Fig. H – 75

- ① Bare concrete ceiling
- ② Sand filler behind the edge insulation strips
- ③ Tiles
- ④ Tar screed (mastic asphalt) with cover
- ⑤ Cardboard cover
- ⑥ Equalising/Insulating layer

## Space requirement for pressing

### Pipe sizes 12–54 mm

For technically flawless press connectors, you need space in which to use the press tool. The following tables contain data indicating the minimum space requirements for a variety of installation conditions.

Note that values for mains operation differ from those for battery operation.

### Pressing between pipes

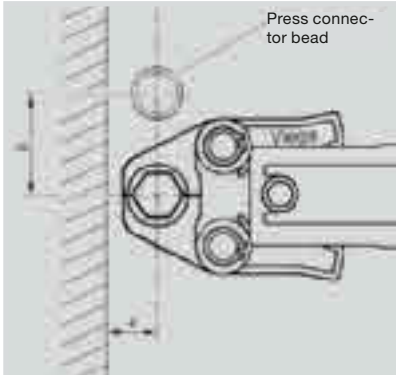

Fig. H – 76

Pipe- $\varnothing$ <sub>a</sub> [mm]	a [mm]	b [mm]
12	20	50
15	20	50
18	20	55
22	25	60
28	25	70
35	30	85
42	45	100
54	50	115

Tab. H – 14  
**Mains operated**

Pressgun 5  
Pressgun 4 E  
PT2  
PT3-EH

#### **Battery**

Pressgun 5/4 B  
PT3-AH

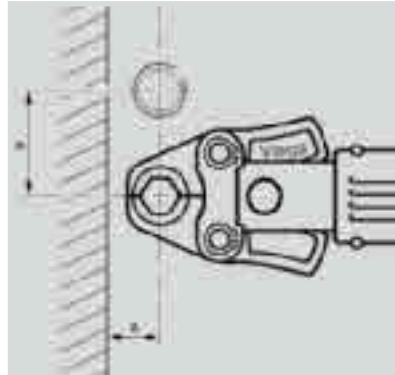

Fig. H – 77

Pipe- $\varnothing$ <sub>a</sub> [mm]	a [mm]	b [mm]
12	25	60
15	25	60
18	25	60
22	25	65
28	25	65

Tab. H – 15  
**Battery**

Picco, Pressgun Picco

### Minimum space requirements

Pressing against structure

### Press tool

With different space requirements

**Minimum space requirements**

**Pressing between pipe and wall**

**Pressgun 5/4B/4E, PT2, PT3-AH, PT3-EH**

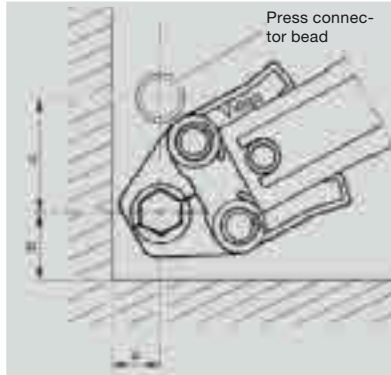

Fig. H – 78

Pipe- $\varnothing d_a$ [mm]	a [mm]	b [mm]	c [mm]
12	25	40	65
15	25	40	65
18	25	40	75
22	30	40	80
28	30	50	85
35	50	50	95
42	50	70	115
54	55	80	140

Tab. H – 16

**Pressgun Picco/Picco**

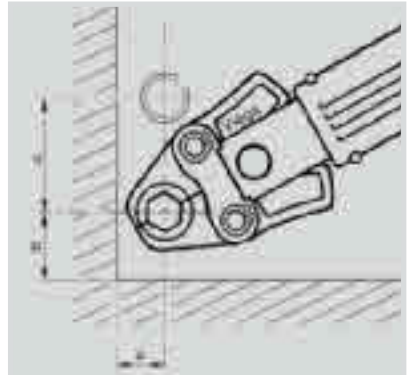

Fig. H – 79

Pipe- $\varnothing d_a$ [mm]	a [mm]	b [mm]	c [mm]
12	30	40	70
15	30	40	70
18	30	40	70
22	30	40	75
28	30	40	80

Tab. H – 17

**Wall spacing**

In combination with a tension jaw,  $a_{min}$  can be reduced

**Pressing between structures**



**Minimum space requirement  $a_{min}$  [mm]**

DN	Pipe- $\varnothing d_a$ [mm]	PT2	PT3-AH PT3-EH	Pressgun Picco Picco	Pressgun 5/4B/4E
10–50	12–54	45	50	35	50

Tab. H – 18

**Distance between pressings**

Canting avoided  
Sealing is assured



DN	Pipe- $\varnothing d_a$ [mm]	Minimum distance a [mm]
10	12	0
12	15	0
15	18	0
20	22	0
25	28	0
32	35	10
40	42	15
50	54	25

Tab. H – 19

## Pipe sizes 64.0 – 108.0 – Prestabo XL

## Space requirements on components

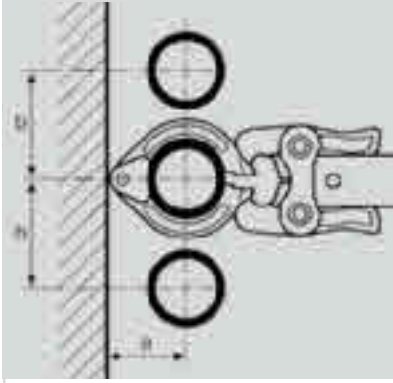

Fig. H – 80

Rohr- $\varnothing$ $d_a$	a	b
[mm]	[mm]	[mm]
64.0	110	185
76.1	110	185
88.9	120	200
108.0	135	215

Tab. H – 20

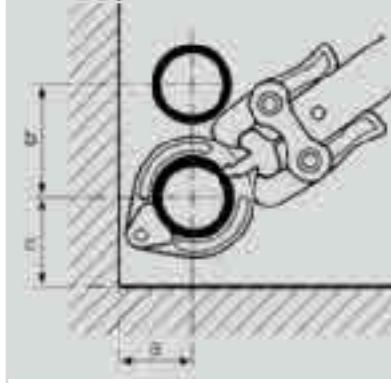

Fig. H – 81

Pipe- $\varnothing$ $d_a$	a	b	c
[mm]	[mm]	[mm]	[mm]
64.0	110	185	130
76.1	110	185	130
88.9	120	200	140
108.0	135	215	155

Tab. H – 21

**Minimum space requirements**

## Pressing between pressings

Pipe- $\varnothing$ $d_a$	Minimum distance a [mm]
[mm]	
64.0	15
76.1	
88.9	
108.0	

Tab. H – 22

Pipe- $\varnothing$ $d_a$	Minimum distance a [mm]
[mm]	
64.0	20
76.1	
88.9	
108.0	

Tab. H – 23

**Space between pressings**

Canting is avoided

Sealing is assured

**Distance to walls**

## Pressing with pressrings 12 – 54 mm

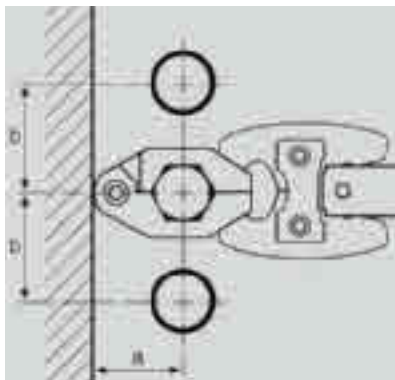

Fig. H – 82

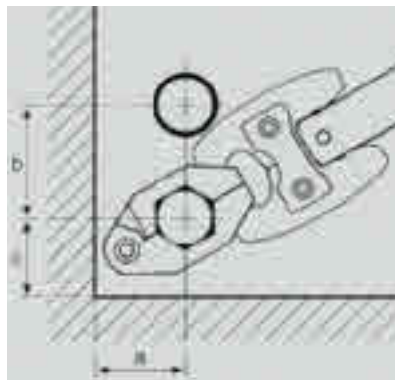

Fig. H – 83

Pipe- $\varnothing$ $d_a$ [mm]	a [mm]	b [mm]	c [mm]
12	40	45	35
15		50	
18	45	55	40
22		60	
28	50	70	45
35		75	
42	60	85	55
54		90	

Tab. H – 24

## Making the press connection

### Pipe sizes 12 – 54 mm

Prestabo pipes are easily and reliably connected. The ends of coated pipes must be dismantled using the Prestabo pipe dismantler to allow the pipe sleeve to be attached. The steps following this are the same for both types of pipe.

- Pipe cutters or a fine toothed saw
- De-burrer and a coloured pen to mark the insertion depth
- Viega-Pressstool with suitable jaw for pipe diameter
- Pipe dismantler

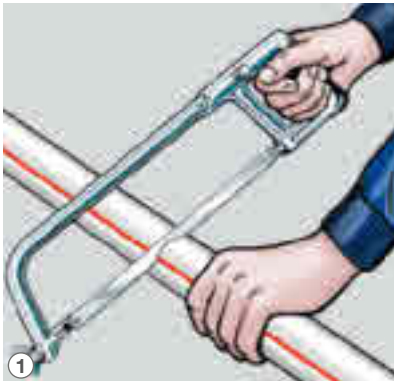

Stripped Prestabo-pipe cut the pipe to length at as near to a right angle as possible with a fine toothed saw.



Dismantle the pipe end with the pipe dismantler.



De-burr internally and externally. Continue with steps for Prestabo-pipe, blank (see next page)

Coated  
Prestabo-pipe

Fig. H – 84  
Fig. H – 85

Fig. H – 86

Use pipe cutter or fine toothed steel saw. Do not use oils or greases!

Prestabo-pipe, blank

Fig. H – 87  
Fig. H – 88



① Stripped Prestabo-pipe cut the pipe to length at as near to a right angle as possible



② De-burr pipe internally and externally.

Fig. H – 89  
Fig. H – 90



③ Check the sealing element is seated correctly.



④ Slide the press connector onto the pipe as far as the stop.

Fig. H – 91  
Fig. H – 92

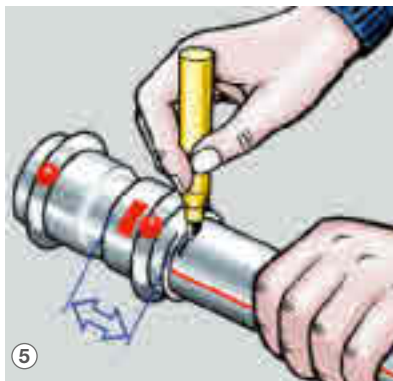

⑤ Mark the insertion depth.



⑥ Place press jaw onto the press tool. Push in the retaining pin until it snaps into place.

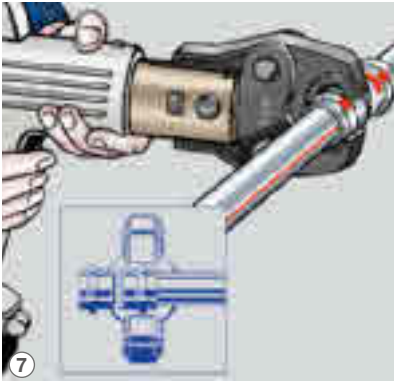

Open press jaw and set a right angle to the connector.



Check the insertion depth and start pressing.



Once press connection complete, open the press jaw.

Prestabo-pipe, blank

Fig. H – 93  
Fig. H – 94

Fig. H – 95



Pipe sizes 64.0 – 108.0mm

Prestabo pipes are easily and reliably joined with press connectors.

**Required tools**

- Pipe cutters or a fine toothed steel saw
- Deburrer and coloured pen for marking insertion depth.
- Viega press tool with press jaw and press ring suitable for pipe diameter

**Prestabo-pipe, blank**

Fig. H – 96  
Fig. H – 97

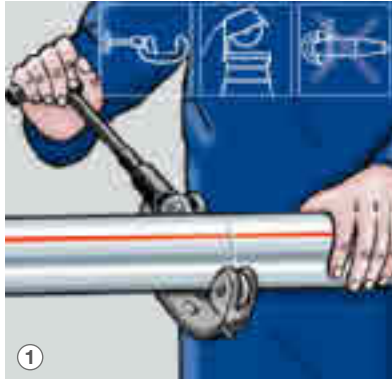

①

Cut the pipe to length using pipe cutters or the fine toothed steel saw. Use no oils or greases.

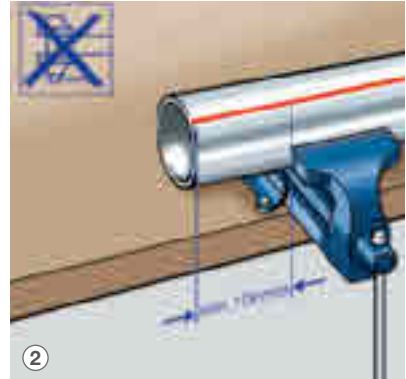

②

Use vice with caution! The end of the pipe must be perfectly round.

Fig. H – 98  
Fig. H – 99

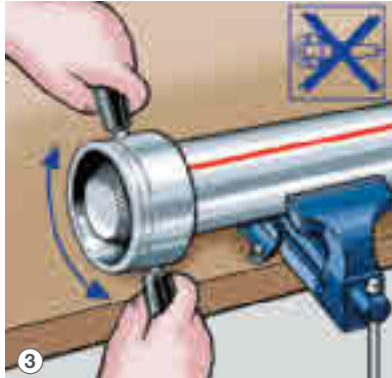

③

De-burr pipe internally and externally.



④

Mark insertion depth  
 $\varnothing$  64.0mm = 43mm  
 $\varnothing$  76.1mm = 55mm  
 $\varnothing$  88.9mm = 55mm  
 $\varnothing$  108.0mm = 65mm

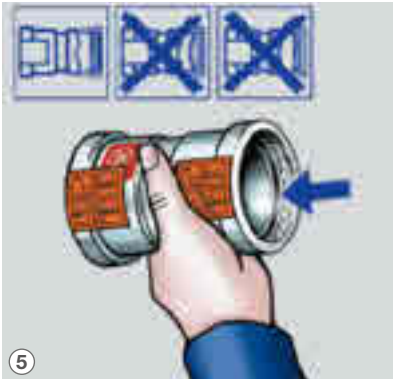

⑤

Check the sealing element and compression ring are seated correctly.

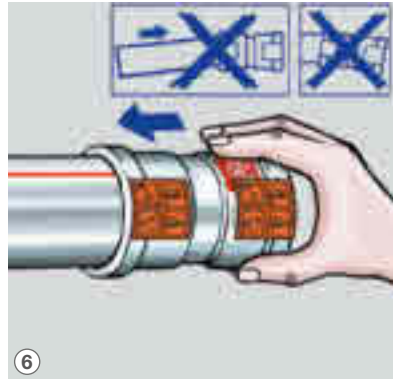

⑥

Slide the connector onto the pipe as far as the insertion depth marking.



⑦

Place the press ring onto the connector and check that the position is correct.



⑧

Open the hinged tension jaw and latch into the receivers on the press ring.

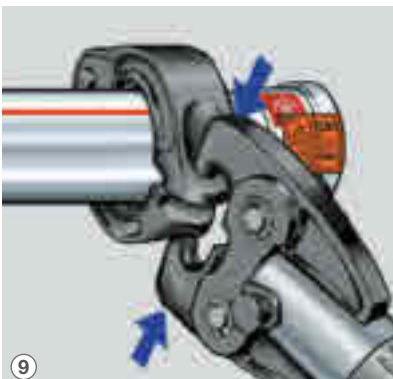

⑨

Start pressing.

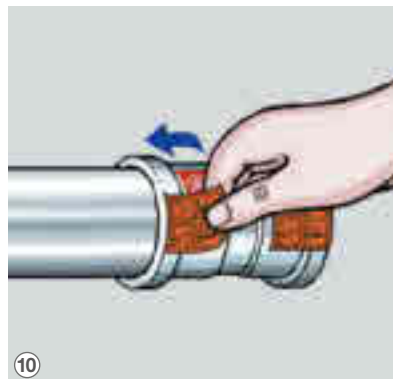

⑩

Remove the control sticker. The connection will now be marked as “pressed”.

Prestabo-pipe, blank

Fig. H – 100  
Fig. H – 101

Fig. H – 102  
Fig. H – 103

Fig. H – 104  
Fig. H – 105

## Leakage test

### Criteria

- Water leakage tests are part of the service contract and the responsibility of the contractor. The system to be tested will be tested with the response pressure of the safety valve.
- Leakage test with oil-free pressurised air or noble gases must be clearly detailed and be included in the contract for work and services.
- All pipes should be tested in a finished installed, but not covered condition.
- The leakage test in heating systems can be carried out using pressurised air or noble gases.
- Leakage tests should be documented.

# 3 Gas installation\*

## Basic principles

### Use of natural gas

Gas installations are normally assembled using metallic piping systems. The relevant national regulations determine the installation process greatly. The following information is based on the technical regulations in Germany and should be regarded as a recommendation, insofar as it does not contradict national regulations.

In Germany over 40 % of domestic heating uses natural gas as its fuel, more than 75 % of new building are fitted with natural gas heating. Alongside natural gas heating with central drinking water heating, cooking or drying clothes with gas is nothing new. It is still remains necessary to inform the customer of the versatility of natural gas and natural gas-fuelled household appliances. New advanced gas appliances such as clothes driers, fireplaces and heat emitters or terraced barbecues add to the range of domestic uses.



Gas powered domestic appliances

Fig. G – 1

## Viega system philosophy

Requirements of an »innovative gas installation« in the household

- Technically efficient and economical installation
- Short assembly times
- Fireproof gas pipes even in inaccessible areas
- Without extra safety measures
- Pipe connections according to HTB (High thermal stability) requirements
- Press connections must be able to be fitted to every type of pipe that is certified for gas installation

House fully catered for by natural gas

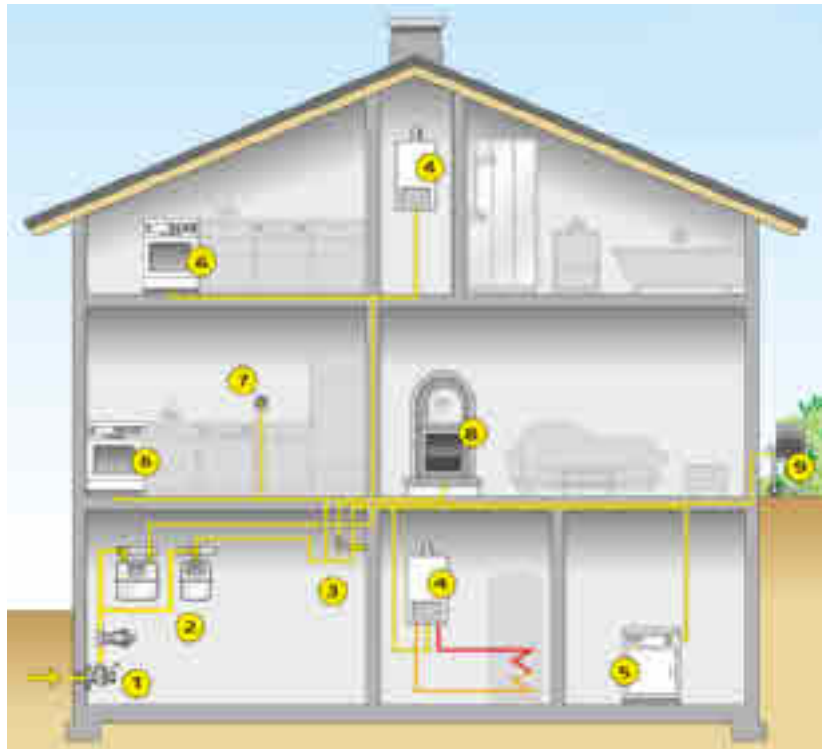

Fig. G – 2

- |  |   |
|--|---|
| ① House inlet with HAE<br>(house service connection) | ⑤ Gas clothes dryer                       |
| ② Gas meter with meter connection<br>plate           | ⑥ Gas oven                                |
| ③ Storey manifold                                    | ⑦ Concealed gas socket                    |
| ④ Warm water boiler                                  | ⑧ Gas fire                                |
|  | ⑨ Outside gas socket with gas<br>barbecue |

## Requirements for gas sockets

National regulations should be observed which either restrict or forbid the use of this type of appliance connection

The use of non-stationed gas appliances such as gas ovens, clothes driers, patio burners and patio grills requires the installation of gas sockets.

The following is required of gas sockets:

- The appliance connection must have a flexible gas hose with a plug which can be connected and disconnected as often as necessary without presenting a danger to the user.
- It must conform to all safety standards
- The design must be similar to that of electric sockets.

During this, constructive solutions are necessary to ensure that safety standards are guaranteed.

Possible dangers and safety measures

- Gas leakage due to ripped or damaged hose
  - monitoring using a gas flow controller
- Unauthorised manipulation of the socket unit
  - Safety through multi stage or lockable fittings
- Gas leakage in case of fire
  - Safety through TAE (thermal shut-off system)
- Improper installation of appliances
  - Safety plug nipple on the gas appliance

Viega concealed and visible gas sockets as well as the flexible gas connection hoses fulfill every one of these requirements.



Fig. G – 3

**Concealed design  
gas socket**

## System descriptions

### Profipress G/Profipress G XL

#### Intended use

The pipe connector systems Profipress G and Profipress G XL are approved for gases according to DVGW-AB G 260 for domestic applications. The installation should be carried out according to DVGW G 600, TRGI 2008 and TRF 2012. Only copper pipes according to EN 1057<sup>1</sup> in conjunction with DVGW-AB-GW 392 may be used.

Approved for

- Gases acc. to DVGW-G 260
- Gas and liquid gas in the gas phase<sup>2</sup> for domestic use

Max. pressure

$p_{\max} = 5 \text{ bar}$

Max. pressure at HTB-requirements

$p_{\max} = 1 \text{ bar}$

Max operating and surrounding temperature.

$T_{\max} = 70^\circ\text{C}$

The use of Profipress G/-XL for applications other than those described above must be approved by Viega Service Center.

<sup>1</sup> Regard the minimum wallthickness acc. to Tab. G-1.

<sup>2</sup> Sanpress Inox G should be used in liquid gas installations in areas with high thermal load (HTB), with a response pressure of the SAV (safety shut-off valve) in the pressure flow device > 1 bar.

#### Profipress G

Press connectors  
made of copper

Special connectors,  
flanges and fittings  
made of gunmetal or  
brass



Fig. G – 4

**Technical data**

Copper pipes acc. to EN 1057

Made of copper/gunmetal

Constantly tested by the material testing commission NRW

Yellow dot on both sides of the press sleeve

Yellow HNBR-sealing element

Viega-Press tools (s. tools chapter)

Profipress G 12 – 54 mm With press jaw

Profipress G XL 64.0 mm With press ring

Profipress G DG-4550 AU 0070

Profipress G XL DG-8531 BR 0258

**Approved pipes in gas installations**

$\varnothing_{\text{external}} \times \text{Minimum Wall thickness}$ $d_a \times s$ [mm]		Rods		Rings
		Hard	Semi-hard	Soft
12 x 0.8	Profipress G	✓	✓	✓
15 x 1.0		✓	✓	✓
18 x 1.0		✓	✓	✓
22 x 1.0		✓	✓	✓
28 x 1.0		✓	✓	–
35 x 1.2		✓	–	–
42 x 1.2		✓	–	–
54 x 1.5		✓	–	–
64.0 x 2.0		XL	✓	–

Tab. G – 1



Fig. G – 5

**Pipes**
**Press connectors**
**Quality control**
**Marking**
**Sealing elements**
**Press tools**
**DVGW-approval number**
**Copper pipes**

Suitable acc. to EN 1057

**Profipress G XL**

Press connectors and flanges



**Profipress G/XL-press connector**

As press connector or with threaded connection

The yellow dot as sign for the SC-Contur – the yellow rectangle for the medium

**Requirements of components in gas installations**

**Markings of the press connectors**

Profipress G and Profipress G XL-Press connections are marked

- Gas For gas piping systems
- MOP 5 Operating pressure 5 bar
- GT/1 at higher thermal stability (HTB at 1 bar operating pressure)

-  For approval in the Netherlands (12 – 54 mm)

-  For approval in poland (12 – 54 mm)

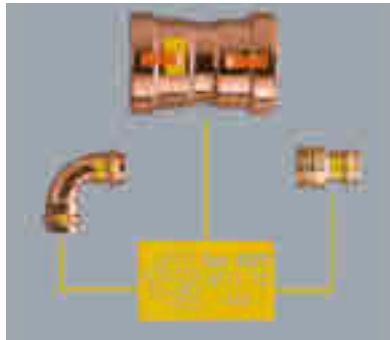

Fig. G – 6

**Advantages of the system**

- SC-Contur
- Press for many connection variations
- Press tools with storage battery or mains operated

**HTB-requirements**

The criteria for high thermal stability are orientated around the ignition temperature of natural gas in the air (approx 640 °C).

To prevent an explosive mixture of gas forming, it is paramount that in case of fire that no dangerous quantity of gas below this temperature is found anywhere in the building. The durability requirements of 650 °C for 30 minutes are in accordance with recognised engineering standards.

## Gas systems

Profipress G- and Profipress G XL-Press connectors can be used in the following gas systems.

Gas systems acc. to DVGW-TRGI 2008

- Low pressure < 100 mbar, medium pressure  $\geq$  100 mbar up to 1 bar
- Industrial, commercial and process technological systems with the relevant DVGW-approval and technical regulation e.g. DVGW-AB G 614, »Exposed pipes on company ground behind the transfer point«



Fig. G – 7

## Liquid gas systems acc. to TRF 2012

For liquid gas installations in areas with a requirement of higher thermal exposure (HTB) with a response pressure of the SAV >1 bar it is necessary to use Sanpress Inox G.

- With liquid gas containers in the medium pressure range
  - with pressure control appliance first stage on the liquid gas container to an approved operating pressure  $P_z = 5$  bar
- With liquid gas container in low pressure range
  - with pressure control device second stage
- With liquid gas pressurised gas container (liquid gas bottles < 14 kg)
  - after the small bottle pressure control device
- With liquid gas pressurised gas container  $\geq$  14 kg
  - after the large bottle pressure control device

## Sanpress Inox G/Sanpress Inox G XL

### Intended use

The press connector piping systems Sanpress Inox G and Sanpress Inox G XL are approved for gases according to DVGW-AB G 260. The installation should be carried out according to DVGW worksheet G 600, TRGI 2008 and TRF 2012.

Only Sanpress stainless steel pipes according to DIN EN 10088 and DVGW worksheet GW 541 – material 1.4401 may be used.

### Approvals

- Gases acc. DVGW G 260
- Liquid gas in the gas phase for domestic and commercial applications.

Maximum operating and surrounding temperature  $T_{\max} = 70\text{ °C}$

Sanpress Inox G/XL – MOP5/GT5

- Max. pressure  $p_{\max} = 5\text{ bar}$
- Max. pressure with at HTB-requirement  $p_{\max} = 5\text{ bar}$

The use of Sanpress Inox G/-XL for applications other than those described above requires approval from Viega Service Center.

### Sanpress Inox G-connectors

Over 250 articles allow nearly every installation and connection variation

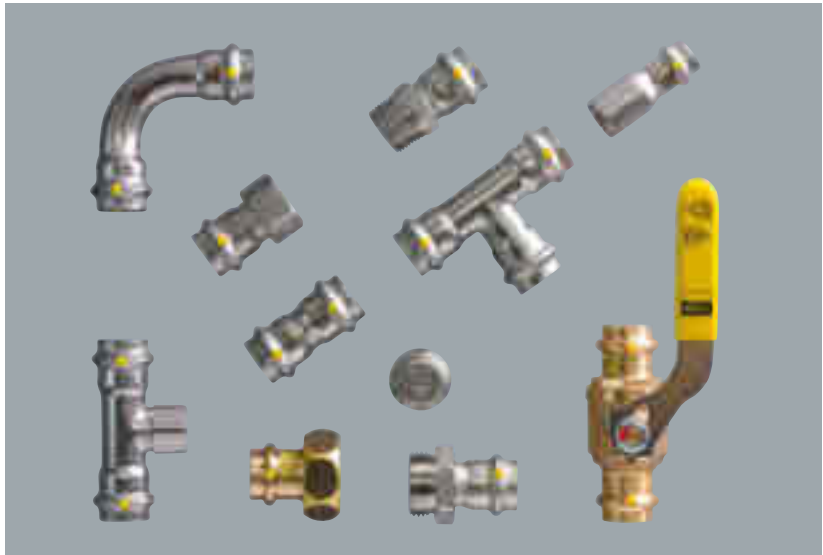

Fig. G – 8

### Technical data

Sanpress stainless steel pipes – thin-walled and corrosion resistant stainless steel pipes. Material no. 1.4401 (X5 CrNiMo 17-12-2) with 2.3 % Mo for higher durability.

All sizes made of stainless steel 1.4401

Constantly tested by the material testing commission NRW

Yellow rectangle and yellow dot on the press sleeve

Yellow HNBR-sealing element

Viega-Press tools (s. chapter »Tools«)

Sanpress Inox G 15 to 54 mm

Press jaw

Sanpress Inox G XL 64.0 to 108.0 mm

Pressring

Sanpress Inox G

DG-8531B00393

Sanpress Inox G XL

DG-8531BR0333

**Pipes**

**Press connectors**

**Quality control**

**Marking**

**Sealing element**

**Press tools**

**DVGW-  
registration number**

### Approved stainless steel pipes

$d_a \times s$ [mm]	Volume per running metre of pipe [Litre/m]	Weight per running metre of pipe [kg/m]	Material Press connector
15 x 1.0	0.13	0.35	Stainless steel
18 x 1.0	0.20	0.43	
22 x 1.2	0.30	0.65	
28 x 1.2	0.51	0.84	
35 x 1.5	0.80	1.26	
42 x 1.5	1.19	1.52	
54 x 1.5	2.04	1.97	
64.0 x 2.0	2.83	3.04	
76.1 x 2.0	4.08	3.70	
88.9 x 2.0	5.66	4.34	
108.0 x 2.0	8.49	5.30	

Tab. G – 2

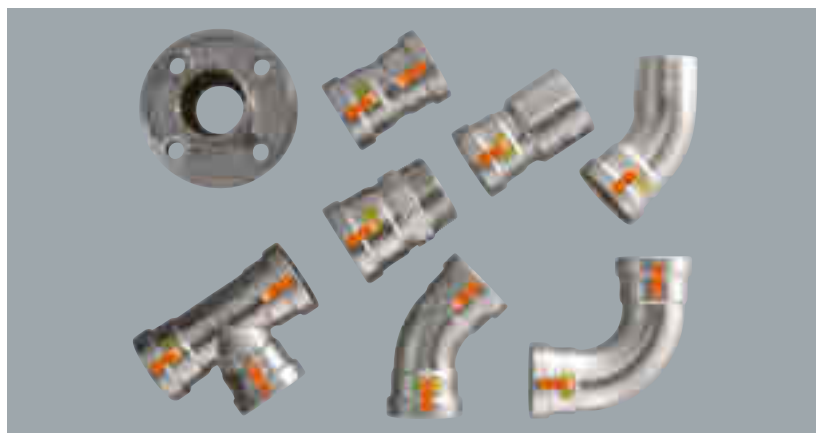

Fig. G – 9

**Sanpress Inox G XL**

Press connectors and  
flanges

**SC-Contur**

Non-pressed connections are noticed during leakage and pressure tests

Up to 108.0 mm with marking for gas

**Sanpress Inox G XL press connectors**

**Markings of the Press connectors**

Sanpress Inox G/XL-Press connectors are marked with

- Gas for Gas piping systems,
- MOP 5 for operating pressure 5 bar,
- GT/5 at higher thermal stability (HTB at 5 bar)

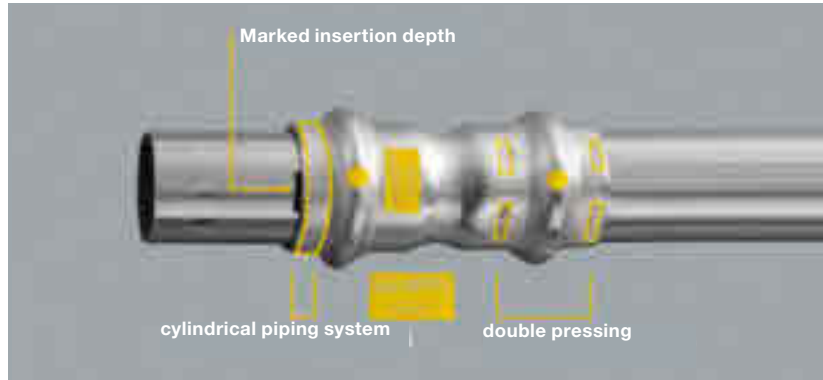

Fig. G – 10

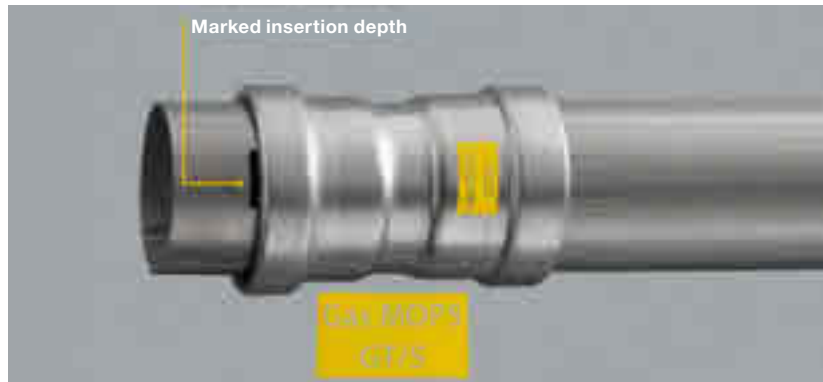

Fig. G – 11

**Press connectors with SC-Contur**

Sanpress Inox G-System is also fitted with the SC-Contur system, noticeable by the yellow dot on the bead. Non-pressed connections can be seen during pressure leakage tests as the pressure loss appears on the manometer.

**Liquid gas system TRF 2012**

See chapter Profipress G.

## Assembly

### General rules of assembly for gas piping systems

The following conditions are valid for the laying of gas pipes

- Gas pipes must be free laid ① with gaps concealed without hollow room ② or in shafts or channels ③.
- Pipes with operating pressures >100 mbar may not be used in concealed installation.
- They should be laid in such a way that dampness, both dripping and condensed water, from other pipes and components do not affect them.
- The shut-off devices and detachable connections must be easily accessible.
- They must not be concealed in screed (see following page).

### Installation examples

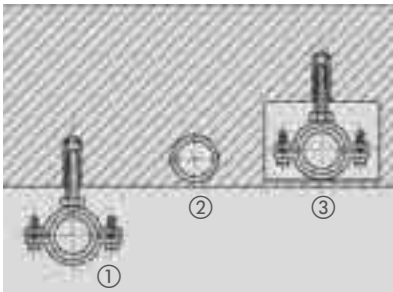

Fig. G – 12

- ① With gaps
- ② Without hollow space
- ③ In ventilated channels

### Requirements for concealed installations

- They must be carried out with zero tension.
- They should be protected against corrosion.
- Detachable connections (threaded connections) are not permissible
- Copper pipes must not be treated with materials containing nitrite or ammonium, stainless steel pipes must not be treated with materials containing chloride

### Pipe installation

According to  
DVGW TRGI 2008

**Pipe installation and fastening**

Gas pipes must not be fastened to or used as support for any other pipes. Gas pipes are only allowed to be supported using non-flammable pipe holders (for example metallic pipe clamps) and standard fastening plugs (plastic) on components with adequate stability when the pipe connection is able to display adequate mechanical axial stability see DVGW-TRGI 2008 5.3.7 Tab. 8. Profipress G/XL and Sanpress Inox G/XL connections are non-detachable, tight and secure press connections.

**Profipress G- and Sanpress Inox G-press connectors**

Connections with considerable longitudinal force



Fig. G – 13

**Benchmark for horizontally laid piping systems**

DN	Ø <sub>external</sub> x Wall thickness [mm]		Fastening interval [m]
	Profipress G	Sanpress Inox G	
-	12 x 0.8	-	1.25
	12 x 1.0	-	1.25
-	15 x 1.0	15 x 1.0	1.25
15	18 x 1.0	18 x 1.0	1.50
20	22 x 1.0	22 x 1.2	2.00
25	28 x 1.0	-	2.25
	28 x 1.5	28 x 1.2	2.25
32	35 x 1.2	-	2.75
	35 x 1.5	35 x 1.5	2.75
40	42 x 1.2	-	3.00
	42 x 1.5	42 x 1.5	3.00
50	54 x 1.5	54 x 1.5	3.50
	54 x 2.0	-	3.50
-	64.0 x 2.0	XL 64.0 x 2.0	4.00
65	-	76.1 x 2.0	4.25
80	-	88.9 x 2.0	4.75
100	-	108.0 x 2.0	5.00

Tab. G – 3

## Laying in floors

Gas pipes may not (not even partially) be laid in screed.

Permitted ways of laying

- On the raw ceiling within a compensating layer or impact sound insulation
- Partially within a cavity in the raw ceiling and partially within a compensating layer or impact sound insulation (see Fig. G – 14)
- Completely within a cavity in the raw ceiling (see Fig. G – 15).

Gas pipes that are laid under screed must be protected against corrosion. DVGW-TRGI 2008, Pt. 3.3.8.5: »Requirements for earth laid piping systems«

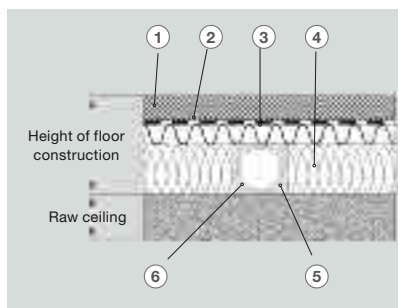

Fig. G – 14

- ① Screed
- ② Film
- ③ Impact sound insulation

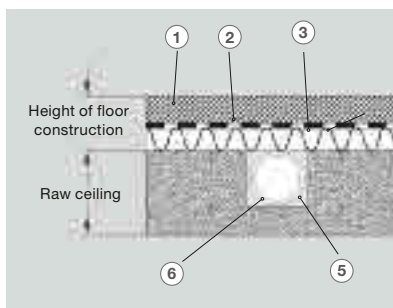

Fig. G – 15

- ④ Compensating layer
- ⑤ Cavity
- ⑥ Gas pipe

## Gas pipes in floor construction

## Corrosion protection

Uncovered pipes in rooms normally require no external corrosion protection.

Exceptions

- In rooms with aggressive building materials – for example, copper pipes in areas with building materials containing nitrite or ammonium or stainless steel pipes in surroundings containing chloride.
- In aggressive atmospheres.
- When they are laid inside a gap in the floor, the equalising course or the footfall insulation they should be treated like earth laid piping systems according to DVGW-TRGI 2008, Pt. 5.3.7.8.4

## Requirements according to DVGW-TRGI 2008 Pt. 5.2.7

Retro fitting of corrosion protection should be carried out with corrosion protective binding or heat shrinkage tubing.

- For copper and stainless steel pipes with exposure class A (non-corrosive floor) or B (corrosive floor).
- For fittings, pipe connections and moulded parts with exposure class A and B, shrink material class C.



## 4 Industrial/commercial uses

### System descriptions

#### Megapress

##### Intended use

The Megapress system is suitable for installations of heating, cooling and industrial systems in connection with steep pipes in accordance with DIN EN 10255 und DIN EN 10220 (see pipe specifications).

##### The Megapress system is not suitable

- For use in drinking water installations – labelling of components with “Not for drinking water installations” symbol.
- For combustion gases as per DVGW G 260

Megapress connectors must only be used together with the components belonging to the system.

Using the system for any other uses than those described must be agreed with the Viega Service Center.

The press connectors are visibly leaky in their unpressed state. A leakage test must be carried out before commissioning.

##### Operating conditions

- Water, closed system
  - Operating temperature  $T_{\max} = 110^{\circ}\text{C}$
  - Operating pressure  $p_{\max} \leq 16\text{ bar}$
- Compressed air, dry and oil-free
  - – Operating pressure  $p_{\max} \leq 16\text{ bar}$

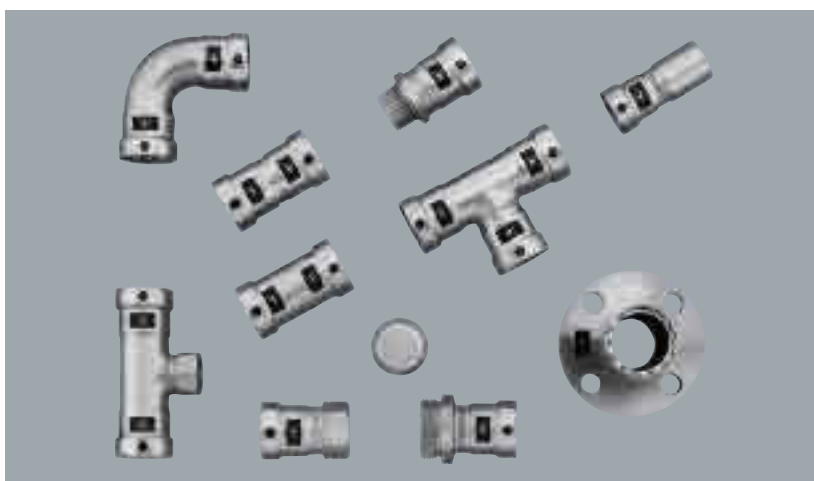

Fig. I – 1

### Technical data

Steel pipes - seamless and welded along the longitudinal seam: black, galvanized, industrially painted or powder coated in accordance with

- DIN EN 10255 (Formerly: DIN 2440, 2441, 2442) or
- DIN EN 10220 (Formerly: DIN 2448 / 1 und 2458/1) with minimal wall thickness  $s_{\min} = 1.0$  mm; to DN 32 with  $s_{\min} = 0.5$  mm.

Steel, non-alloy, material 1.0308, with high-quality zinc-nickel coating 3 – 5  $\mu\text{m}$

EPDM with integrally shaped sealing lips, for  $T_{\max} \leq 110$  °C and  $p_{\max} \leq 16$  bar

½ (DN 15), ¾ (DN 20), 1 (DN 25), 1 ¼ (DN 32), 1 ½ (DN 40), 2 (DN 50)

[www.viega.de/Service / Download Center](http://www.viega.de/Service/DownloadCenter)

VDS – For wet and wet / dry sprinklers; TÜV; shipbuilding; various country licences – e.g. for France: CSDBat

### Uses

Use of welded and threaded connections for new installations and repairs

- Closed heating and cooling circuits
- Industrial systems – nitrogen, etc.
- Compressed air systems
- Fire extinguisher and sprinkler systems
- Systems for technical gases (on request)

### Features / advantages

- Rapid processing, without handling of gas bottles or thread-cutting machinery – time saving of up to 60%
- No smoke, no risk of fire, damage, fireguard, cooling phases
- Zinc-nickel coating 3 – 5  $\mu\text{m}$  – corrosion resistant with a long life span
- Profile sealing element for rough pipe surfaces

**Rohre**

**Press connectors**

**Sealing element**

**Sizes**

**Z-dimension**

**licences**

- ① Profile sealing element
- ② Cutting ring
- ③ Separating ring

**Profile sealing element**

Megapress press connectors are equipped with specially designed EPDM sealing elements. Integrally shaped sealing lips with several sealing levels safely seal even pipe surfaces with slight unevenness or grooves.

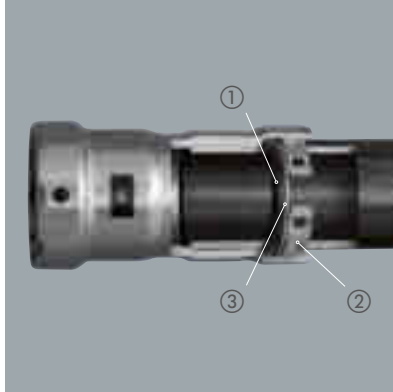

Fig. I – 2



Fig. I – 3

**Press connectors - leaky when unpressed**

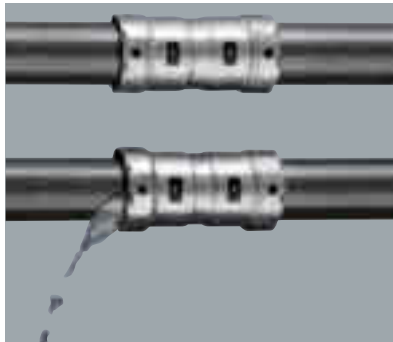

Fig. I – 4

Megapress press connectors are leaky in their unpressed state.

Inadvertently unpressed connections easily become visible when the system is filled.

- with water in the pressure range from 1.0 to 6.5 bar,
- with air or inert gases in the pressure range from 22 mbar to 3.0 bar.

Repairs and system expansions

**Sliding collar**



Fig. I – 5

The Megapress sliding collar has no internal block, meaning it is generally used for repairing defective pipe sections or expanding systems - e.g. for installing T-pieces in cramped conditions.

## Assembly

### Pressing tools

Megapress press connectors are pressed with special press jaws / press rings. The press rings / press jaws of the metallic Viega press connector systems “Profipress, Sanpress, Sanpress Inox and Prestabo” cannot be used.

Press connections up to DN 25 are created using press jaws, for dimensions DN 15 to DN 25 press rings can be used.

We recommend using Viega press jaws, press rings and hinged press jaws.



Fig. I – 6



Fig. I – 7

**Use the system's own pressing tools!**

#### Press jaws

DN 15 to DN 25  
Model 4299.9

#### Press rings

DN 32 to DN 50  
Model 4296.1

### Pressing tools - For Megapress press connectors

Press machines	Press jaws	Press rings	Set
Type 2			
PT 3 AH / EH	DN 15 to DN 25 Mod. 4299.9	DN 32 to DN 50, model 4296.1	Press jaws DN 15 to DN 25 Press rings DN 32 to DN 50
Pressgun 4 / 5		With hinged press jaws Z2 Model 2296.2	Hinged press jaws Mod. 4299.61

Tab. I – 1

### Steel pipes

In accordance with  
DIN EN 10255 and  
DIN EN 10220  
(minimum wall thick-  
ness 1.0 mm)

**Smooth, clean,  
non-deformed pipe  
surfaces are requi-  
red**

## General assembly information

To comply with the high quality of the Megapress system components, the following advice should be followed

- Only remove Megapress system components from the packaging directly before use.
- Only use conventional chloride-free sealants to seal the threads of the adapter pieces to Viega press connections.
- Always create the threaded connection first when assembling components or pipe sections with combined threaded and press connections.

## Trimming and refining of pipes

The steel pipes can be separated using the following tools, taking into account the pipe coating

- Pipe cutter
- Fine-toothed saws
- Compound mitre saw – slow cutting speed required
- Angle grinder

Deburr both the inside and outside of the pipe after trimming.

## Preparation of pipe ends for press connections

The Megapress system is suitable for the use of black, galvanised, industrially painted or powder-coated steel pipes in accordance with DIN EN 10255/10220.

To guarantee technically flawless press connections are created, undamaged, non-deformed pipes and sufficiently smooth and clean pipe ends, which are free from loose particles of dirt and rust, are needed.

Requirements on pipe ends

- Technically accurate, right-angled cut-to-length
- Internal and external pipe wall free from burrs
- Round cross section, without deformations, e.g. vice marks
- Minimum interval to welded seams  $3 \times D$  – but at least 100 mm

Requirements on pipe surfaces

- Smooth and even – without damage e.g. from vices or threading machines
- Free of grease and oil
- Free from loose particles of dirt and rust and unevenly (manually) applied coatings

### Examples

Without further treatment, the following pipe surfaces are suitable for creating press connections, if they are free from any dirt or damage

- ① Black,
- ② alvanized,
- ③ Industrially painted / powder-coated pipes.

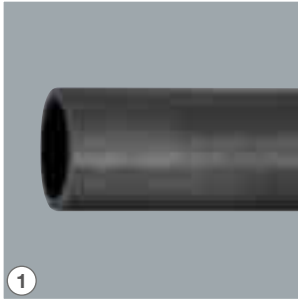

Fig. I – 8



Fig. I – 9

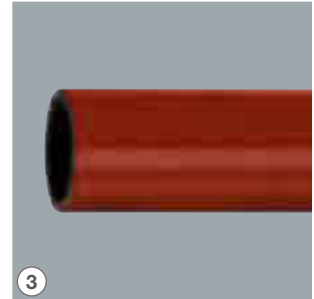

Fig. I – 10

Before creating the press connection, the pipe surfaces around the press connections must be refined if they have the following properties

- Unevenly applied paint layers Fig. I-11
- Bumps, damage, corrosion and loose adhesions Fig. I-12



Fig. I – 11



Fig. I – 12

**Refine these issues before creating the press connection!**

Suitable tools for refining include

- ① Wire brushes
- ② Cleaning fleece/abrasive emery paper
- ③ Angle grinder with roughing disc.



Fig. I – 13



Fig. I – 14



Fig. I – 15

After making these refinements, the quality of the pipe surface should be as shown in Fig. I-16.



Fig. I – 16

### Pipe attachments

The general rules of fastening technology apply - e.g.

- No additional pipes or components must be attached to existing pipe installations.
- The use of pipe hooks is not permitted.
- Take into account thermal expansion – plan fixing and floating points.

### Fastening intervals

Ø <sub>external</sub> [mm]	Nominal width		Fastening interval (m)	
	[DN]	[inch]	In acc. with manufacturer's instructions	In acc. with VdS CEA 4001
21.3	15	½	2.75	4.00
26.9	20	¾	3.00	
33.7	25	1	3.50	
42.4	32	1¼	3.75	
48.3	40	1½	4.25	
60.3	50	2	4.75	

Tab. 1 – 2

### Protection from external corrosion / insulation

The high-quality zinc-nickel coating of the press connector offers the best protection from corrosion – e.g. for arising condensation in cooling systems.

The pipes must be provided with suitable corrosion protection - take note of the manufacturer's information.

Pipes and connectors must be insulated according to the generally accepted rules of technology.

### Commissioning

A pressure test must be carried out before the system is put into operation – the result must be documented.

Procedure

- Completely fill the system with the test medium – e.g. inert gas / filtered drinking water.
- Carry out pressure test – for sprinkler systems, please note VdS CEA 4001, Chapter 17.
- Document the results of the pressure test in a log.
- Provide the client with the log, which has been confirmed by an authorised technician.



Creating the press connection

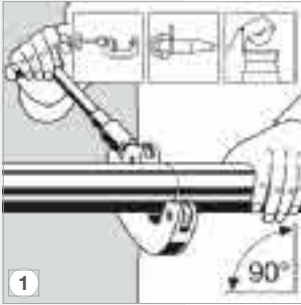

Fig. I – 17

Trim the steel pipe professionally, right-angled with pipe cutter, angle grinder or fine-toothed saw – Do not use a flame cutter.

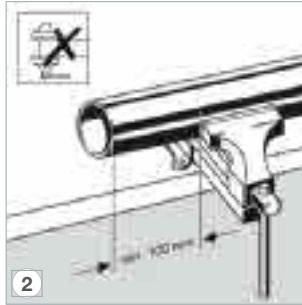

Fig. I – 18

Pay attention when clamping – avoid deforming the pipe end.

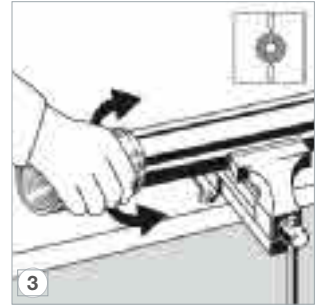

Fig. I – 19

Deburr the inside and outside of the pipe with a deburrer – up to DN 40 with Mod. 2292.2, DN 50 with Mod. 2292.4 XL

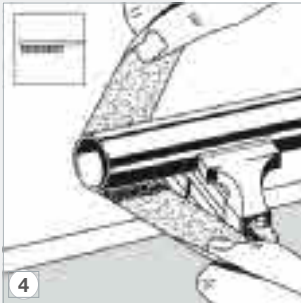

Fig. I – 20

Remove any particles of dirt or rust from the pressing area using wire brushes and cleaning fleece or abrasive emery paper.

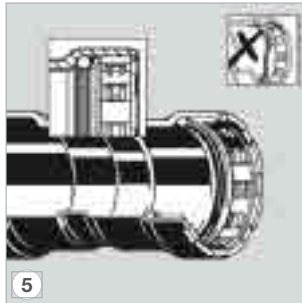

Fig. I – 21

Ensure the sealing element, separating ring and cutting ring are positioned correctly.

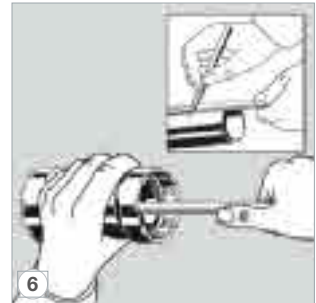

Fig. I – 22

Measure the insertion depth and mark it on the pipe.

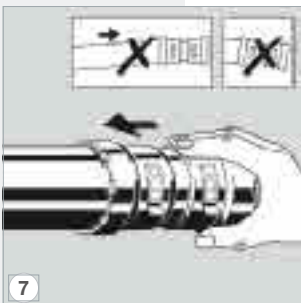

Fig. I – 23

Slide the press connector - without twisting - as far as it will go along the pipe.

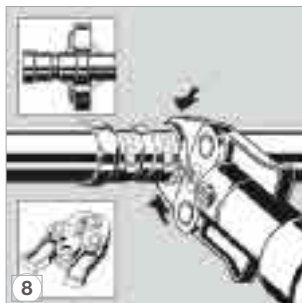

Fig. I – 24

Position Megapress press jaws ( $\leq$  DN 25) around the press connector – Make sure they are positioned correctly. Carry out the pressing procedure until the press jaws are completely closed.

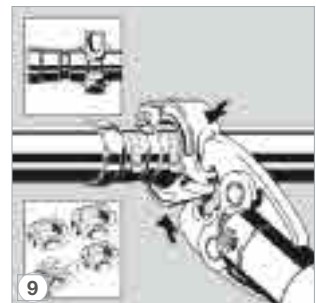

Fig. I – 25

Position the Megapress press ring ( $\geq$  DN 32) around the press connections – Make sure it is positioned correctly. Carry out the pressing procedure with the help of the press jaws until the press ring is completely closed.

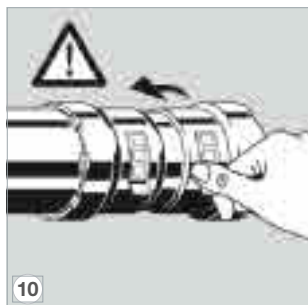



Fig. I – 26

Remove the control sticker - this labels the connector as “pressed”.

### Space requirement when pressing

Space is required to position the press machine for a technically flawless press connection. The following tables contain information about the minimum space requirement in various installation situations.

#### Pressing between pipes - press jaws up to DN 25

	Size	a	b
	½	30	70
	¾	35	80
	1	45	95

Tab. I – 3

#### Pressing between pipe and wall – press jaws up to DN 25

	Size	a	b	c
	½	35	50	80
	¾	40	55	90
	1	50	65	105

Tab. I – 4

#### Distance to wall – press jaws up to DN 25

	Größe	Minimum space requirement a <sub>min</sub> {mm}
	½	50
	¾	
	1	

Tab. I – 5

Press jaws

## Press rings

## Minimum distance between the pressings - press jaws up to DN 25

		Minimum space requirement $a_{\min}$ [mm]
	Size	5
	1/2	
	3/4	
	1	

Tab. I – 6

## Pressing between pipes - press jaws DN32 –DN50

		a	b
	Size		
	1 1/4	95	125
	1 1/2	105	135
	2		140

Tab. I – 7

## Pressing between pipes - press jaws DN32 –DN50

		a	b	c
	Size			80
	1 1/4	95	125	
	1 1/2	105	135	
	2		140	

Tab. I – 8

## Distance to wall – press rings DN 32 – DN50

		Minimum space requirement $a_{\min}$ [mm]
	Size	20
	1 1/4	
	1 1/2	
	2	

Tab. I – 9

## Minimum distance between the pressings - press jaws DN32 - DN50

		Minimum space requirement $a_{\min}$ [mm]
	Size	15
	1 1/4	
	1 1/2	
	2	

Tab. I – 10

## Profipress/Sanpress Inox/Profipress G/Sanpress Inox G/Prestabo

### Intended use

The press connector systems Profipress/Profipress G as well as Sanpress Inox and Sanpress Inox G are suitable for the transportation of special media in industrial conditions.

The choice of system is dependent on the particular operating conditions such as pressure, temperature and concentration and the media to be transported. The suitability of the Prestabo systems as well as all of the systems for further media can be checked with Viega Service Center by filling out of the material request form (Checklist at the end of chapter).

The systems Profipress/Profipress G as well as Sanpress Inox and Sanpress Inox G are not only being used in domestic installations, but also for the transportation of special media.

Many operating conditions of the media, such as pressure, temperature and concentration demand a great deal of thought when choosing the system and sealant. Special media with prescribed operating conditions, for example, technical gases, oils, lubricants etc. can be examined by in Viega's own facilities or in special cases other laboratories, if required.

With help from this information, the areas of use which ensure the maximum safety for running the unit and for the builder can be worked out.

The press connector systems made of copper and stainless steel are preferred in the following units.

- Pressurised air
- Cooling water
- Technical gases
- Operating water
- Processed water
- Media containing oil

### Areas of use

**Press connector range**

## Profipress / Profipress G



Fig. I – 27

Approved for

- Gas and liquid gas
- Heating oil and diesel fuel
- Wet sprinkler systems
- Oxygen piping systems
- Connector labs-free (Free of substances aggressive to laquer )

**Press connector with SC-Contur**

The SC-Contur is marked in colour on every connector

- Yellow Profipress G-connectors
- Green Profipress-connectors,
- White Profipress with FKM sealing element.

**Press connectors**  
coloured dots mark  
the SC-Contur

### Installation

With Profipress and  
Profipress XL



Fig. I – 28



Fig. I – 29

**Technical data**

Only use copper pipes acc. to EN 1057 Regard the minimum wallthickness acc. to Tab. H-1

Press connectors with threaded joint

- 12 – 54 mm gunmetal
- 64.0 – 108.0 mm copper

Black: EPDM (ethylene propylene diene rubber) up to 110 °C – not resistant to hydrocarbon solutions or chlorinated hydrocarbons, turpentine and petrol

Bars and rolls (s. table)

Profipress with SC-Contur                      DVGW-Reg.-Nr. DW-8511AP3139

Profipress XL                                        DVGW-Reg.-Nr. DW-8511AT2347

Copper pipes                                        EN 1057 and DVGW GW 392

12/15/18/22/28/35/42/54

64.0/76.1/88.9/108.0

**Pipes to be used in drinking water installations**

External-Ø x Wallthickness d <sub>a</sub> x s [mm]	Delivery range			Sizes	Material Press connectors
	Rods		Rings		
	Hard	Semihard	Soft		
12 x 0.8	✓	✓	✓	Standard	Copper
15 x 1.0	✓	✓	✓		
18 x 1.0	✓	✓	✓		
22 x 1.0	✓	✓	✓		
28 x 1.0	✓	✓	✓		
35 x 1.2	✓	–	–		
42 x 1.2	✓	–	–		
54 x 1.5	✓	–	–		
64.0 x 2.0	✓	–	–		
76.1 x 2.0	✓	–	–	XL	
88.9 x 2.0	✓	–	–		
108.0 x 2.5	✓	–	–		

Tab. I – 11

**Pipe material**

**Press connectors-  
material**

**Sealing elements**

**Delivery condition**

**Approvals**

System

**Nominal sizes [mm]**

**Profipress XL**

**Pipe sizes,**

**delivery condition**

## Sanpress Inox/Sanpress Inox XL

### Pipe material

Ref.-standard EN 10312

### Press connector material

### Sealing element

### Delivery condition

### Approvals

System

Pipes

### Nominal sizes [mm]

Sanpress Inox

Sanpress Inox XL

### Sanpress Inox

Press connectors  
15 – 54 mm  
stainless steel,

XL-Sizes  
64.0 – 108.0 mm  
stainless steel,  
with compression ring,  
separating ring and  
EPDM-sealing element

All sizes with  
SC-Contur

### Technical data

Sanpress- and Sanpress XL-stainless steel pipes are laser welded conduit pipes made of stainless steel.

Material no. 1.4401 (X5 CrNiMo 17-12-2), with 2.3 % Mo for higher durability  
alternative: Material no. 1.4521 (X2 CrMoTi 18-2), with a PRE-value of 24.1

Stainless steel

EPDM (Ethylene-Propylene-Diene-Rubber); up to 110 °C; not resistant to hydrocarbon solutions or chlorinated hydrocarbons, turpentine and petrol

6 m Lengths, with blank external and internal surface

Pipe ends with plastic caps

All pipes are tested for leakage and marked as such

DW-8501BL0551 – 15 – 54 mm

DW-8511BQ0245 – 64.0 – 108.0 mm

EN 10088: List of stainless steels

DVGW W 541: Pipes made of stainless steel for drinking water installations,  
DVGW-Test symbol TS 233 (N 012)

15/18/22/28/35/42/54

64.0/76.1/88.9/108.0



Fig. I – 30



Fig. I – 31

**Sanpress Inox-Pipes**

d x s [mm]	Volume per metre pipe [Liter/m]	Weight per metre pipe [kg/m]	Weight per 6 metre length [kg]	Size	Material Press connector
15 x 1.0	0.13	0.35	2.10	Standard	Stainless Steel
18 x 1.0	0.20	0.43	2.55		
22 x 1.2	0.30	0.65	3.89		
28 x 1.2	0.51	0.84	5.02		
35 x 1.5	0.80	1.26	7.55		
42 x 1.5	1.19	1.52	9.13		
54 x 1.5	2.04	1.97	11.83		

**Sanpress Inox XL-Pipes**

64.0 x 2.0	2.83	3.04	18.24	XL	Stainless Steel
76.1 x 2.0	4.08	3.70	22.20		
88.9 x 2.0	5.66	4.34	26.00		
108.0 x 2.0	8.49	5.30	31.80		

Tab. I – 12



## Prestabo

### Intended use

The Prestabo-System is designed for use in industrial and heating units and not suitable for use in drinking water installations. Pipes and connectors are therefore marked with a red symbol “Not suitable for drinking water installations”.

The sendzimir galvanised Prestabo-pipe can also be used for wet sprinkler systems and pressurised air installations.

### Prestabo-press connector

With visible red marking:  
“Not suitable for drinking water installations”



Fig. I – 32



Fig. I – 33

### Characteristics of sendzimir galvanised pipes for sprinklers

- Red line, white writing
- Symbol »Not for drinking water installations«
- Symbol »Sprinkler«
- Pipe ends with white caps
- Sizes 15-108.0 mm
- From size 22 mm upwards, VdS certification for pipe and press connectors
- 20 µm zinc layer, internal and external

# Application technology

## SC-Contur – DVGW-tested safety

The SC-Contur flags up non-pressed press connectors when the system is filling up. Non-pressed press connectors (indicated by water leaking or the pressure reading on the test gauge) can be detected reliably at pressures from 1 bar to 6.5 bar and pressed immediately.



### SC-Contur

Non-pressed connectors are flagged up when filling the system

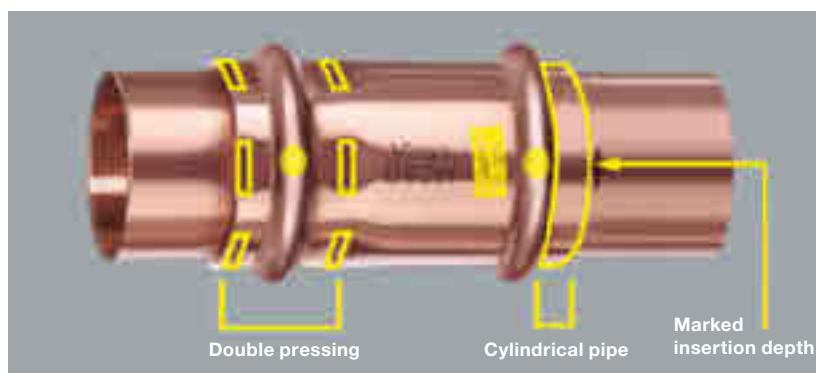

Fig. 1 – 34

### Viega tests

Test criteria	Requirements according to DVGW-W 534	Viega test values
Resistance to pressure	At least. 25 bar	Between 50 and 200 bar
Pressure surge	Every 10,000 times, alternating between 1 and 15 bar excess pressure at room temperature and 95°C	Every 10,000 times, alternating between 1 and 15 bar excess pressure at room temperature and 95°C
Temperature changes	Every 10,000 times alternating. Every 15 minutes at 20 °C and 95 °C at a pressure of 10 bar and pre-stressing of 2N/mm <sup>2</sup>	Every 10,000 times alternating. Every 15 minutes at 20 °C and 95 °C at a pressure of 10 bar and pre-stressing of 2N/mm <sup>2</sup>
Negative pressure		-0.8 bar
Sealing elements		Special test

Tab. 1 – 13

For Sanpress, Sanpress Inox, Profipress

The tested load of the components are well above the values required

## Technical data sealing elements

## Sealing elements

Abbreviation	EPDM	HNBR	FKM
Material	Ethylene-Propylene-Diene-Rubber	Acrylnitril-Butadiene-Natural rubber	Fluor-elastomer
colour	Black-gloss	Yellow	Black-matt
Temperature [°C max.]	110	70	140
Pressure [bar]	16	PN5/GT 1	16
KTW	Yes	No	No
HTB	No	Yes	No
Area of Application	DW Heating Solar (Flat collectors)	Gases acc. to GW260 Heating oil Diesel fuel acc. EN 590	Solar (Pipe collectors) District heating (Consultation required)

Tab. I – 14

## Flowchart

## Material request

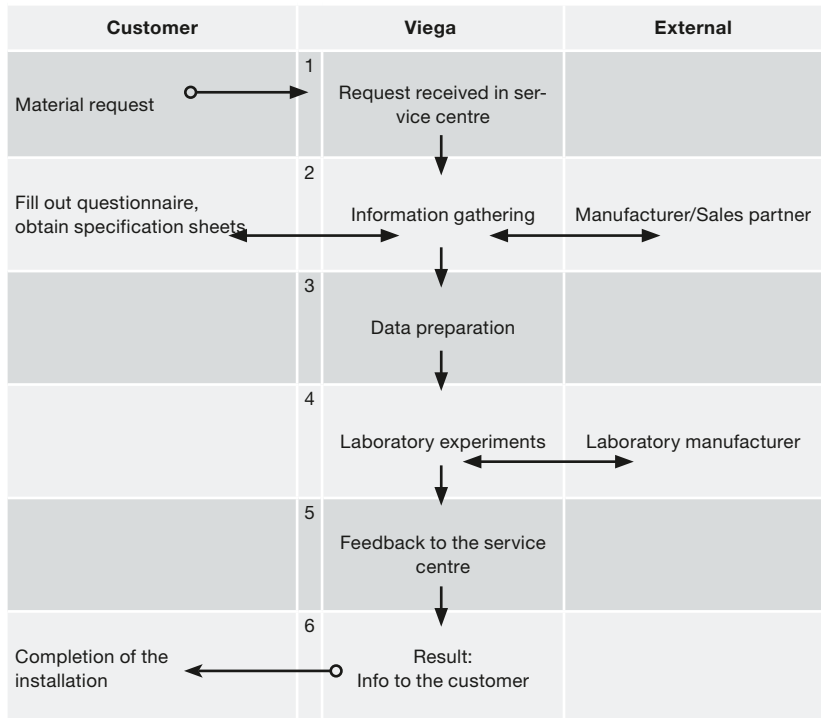

Tab. I – 15

## Flanged connections

Flanged connections in sizes between 28.0 and 108.0 mm may be metallic press systems.

Stainless steel flanges in sizes between 64.0 and 108.0 mm are available for Sanpress Inox and can be provided with press connector sleeves or female threads.

Seals made from EPDM or asbestos-free sealant should be selected depending on the area of application



Fig. I – 35

### Sanpress Inox Fixed flange

Stainless steel 1.4401 (press sleeve)

15 – 54 mm                      Model 2359

64.0 – 108.0 mm              Model 2359XL



Fig. I – 36

### Sanpress Flexible flange, flexible

steel, black powder-coated,  
with gunmetal press connector

28 – 54 mm                      Model 2259.5

64.0 mm (copper)              Model 2459.5XL

XL 76.1 – 108.0 mm          Model 2259.5XL

## Types of flange

## Areas of use

### Compressed air systems

Compressed air is one of the most important media in industry and is used in various qualities and quantities. As a compressed medium, it places a high demand on the connection points on the pipes and the press connections. Alongside the operating safety, the choice of the suitable pipe system plays an important role. Compressed air produced in compressors contains finely distributed oil, which precipitates onto the inside wall of the pipe and can attack unsuitable materials. Copper from Profipress/Profipress G and stainless steel from Sanpress Inox/Sanpress Inox G are corrosion resistant. The factory fitted EPDM sealing elements from the Profipress und Sanpress Inox systems should only be used with an oil concentration of  $\leq 25 \text{ mg/m}^3$ . If the concentration is higher, then we recommend the use of HNBR sealing elements with Profipress G and Sanpress Inox.

**Viega press connector systems**

**Areas of use**

Viega Press connector system	Operating pressure p <sub>max</sub> [bar]	Oil concentration	
		≤25 mg/m <sup>3</sup>	≥25 mg/m <sup>3</sup>
Profipress / Sanpress Inox	16	✓	–
Profipress G / Sanpress Inox G		✓	✓
Sanpress		✓	Use HNBR or FKM
Prestabo	16	✓	FKM

Tab. I – 16

**Compressed air consumer**

With pressure reducer and oil and water separator



Fig. I – 37

**Air quality classes**

ISO 8573-1 classes	Oil concentration max. [mg/m <sup>3</sup> ]
1	≤0.01
2	≤0.1
3	≤1.0
4	≤5.0
5	≤25.0

Tab. I – 17

When assembling a compressed air piping system, the current safety guidelines and regulations of the professional governing body must be observed.

**Aircompressor**

Source Fa. Kaeser



Fig. I – 38

### Cooling water systems

A carrier medium of water or a mixture of up to 50 % water glycol is used in the transport of cooling water in many industrial production processes. The pipe systems Profipress Sanpress Inox and Sanpress can be used in cooling water systems.

For use in connection with bore and cooling emulsions, it is necessary to obtain confirmation from Viega Service Center. The Profipress system is not suitable for the transport of cooling agents.



Fig. 1 – 39

In the interest of operating safety of professionally fitted installations, systems carrying different media must be visibly marked.

**Cooling water-circuit**  
Hydraulic system

**Process water system**

Water prepared for chemical, medical and other processes is known as processed water or treated water. It deals with water which is not suitable for drinking according to current regulation\*.

Treated water is split into different categories. These include

- Partially or fully desalinated water
- Softened water
- Re-treated water
- De-mineralised and de-ionised water
- Osmose-Water etc.

Before installing, it is necessary to carry out a case study and consult Viega Service Center.

**Preparation-system for process water**

**Advice for laboratories**

Treated water are more chemically aggressive than drinking water and that is why they contain metal ions from the piping systems



*Fig. 1 – 40*

**Sanpress Inox**

Recommended for demineralised Water

Fully desalinated water is free from salts and their ions. It has a low conductivity and high solubility factor and therefore attempts to dissolve materials in its environment for example the materials of the piping system. In softened water the calcium and magnesium ions of the carbonates have been exchanged for sodium ions. When using copper the low pH value increases the possibility of an even surface corrosion.

The pipe system Sanpress Inox and the suitable press connectors are especially suitable for softened water. Substances in the material are lost in barely measurable quantities.

### Systems for technical gases

The expression »technical gases« is used as a general term for gases used in the chemical and pharmaceutical industry.

The technical ruling for pressurised gases splits gases according to their qualities. Not only gases but also gas mixtures (natural gas etc.) are determined this way. For the transportation of a variety of these media it is possible to use the Profipress, Profipress G, Sanpress Inox and Sanpress Inox G pipe systems.

The choice of the suitable press connector system with the suitable sealing element for the application of Profipress, Profipress G and Sanpress Inox/Sanpress Inox G is shown in the following table.

**Technical gases and suitable connector systems**

	Profipress/ Sanpress Inox <b>EPDM-sealing element</b>	Profipress G/ Sanpress Inox G <b>HNBR-sealing element</b>	<b>Operating pressure</b> $P_{max}$ [bar]
<b>Compressed air</b>	✓	✓	16
<b>Carbon dioxide CO<sub>2</sub> dry</b>	–	✓	
<b>Nitrogen N<sub>2</sub></b>	✓	✓	
<b>Argon</b>	✓	✓	10
<b>Corgon-protective gas</b>	✓	✓	16
<b>Vacuum</b>	✓	✓	1.0 mbar
<b>Oxygen</b>	✓	–	10
<b>Natural and liquid gas</b>	–	✓	5

Tab. I – 18

For applications other than those mentioned here it is necessary to obtain permission from Viega Service Center.



Fig. I – 41

**Manifold block**  
For technical gases



Technical gases are used in many applications. In the chemical industry, Carbon Dioxide is used for cooling or for cleaning steel. Oxygen is used for producing ozone. Nitrogen and Argon are used in the chemical and pharmaceutical industry in large quantities as protective gases for inertisation.

For many applications the standard quality is not sufficient and the high quality is reduced due to impurities which enter the system through leakages or reactions with gases with the materials of fittings of pipe systems.

Where the boundaries of conventional industrial gases have been reached above average gas qualities with high levels of purities are required. In these purest gases impurities such as minerals and trace elements are only to be found in ppm range (parts per million). The purity of gases is determined according to a point notation system, a shortened form of the percentage the number before the point defines the number of 9's the number behind the point is the first number which is not a nine,

Examples

- Nitrogen **3.8** Purity 99.98 Vol.-%  
3 »nines«, the last number is »8«
- Acetylene **2.4** Purity 99.4 Vol.-%  
2 »nines«, the last number is »4«

**Supply pipe**

For technical welding gases



Fig. I – 42

### Low pressure steam systems

The Profipress-System may only be used in low pressure steam systems with FKM-sealing elements.

- Maximum temperature 120 °C
- Maximum pressure 1 bar



Fig. I – 43

#### Low pressure steam system

<b>Press system</b>	Profipress S or Profipress with FKM Sealing element
<b>Name</b>	Fluor-Elastomer
<b>Area of use</b>	Solar thermic systems Vacuum pipes District heating systems
<b>Colour</b>	Black, matt
<b>Sizes</b>	12 – 108.0mm

Tab. I – 19

With FKM-sealing elements, in conjunction with fittings for steam systems



Fig. I – 44

#### Low pressure steam system

System for the disinfection of hospitalbeds

It is necessary to consult Viega Service Center for applications with higher temperatures or pressures.

### Application in shipbuilding

Profipress is approved for shipbuilding. Address all queries to our agents or our service department.

**Sanpress Inox/Prestabo Labs-free**

In the automobile industry and paint shops only piping systems which are free from lacquer network destructive substances (labs), such as silicone, fat, oil etc. may be used. These materials can cause problems on the surface during the production process resulting in lacquer damage.

If connectors with lab free qualities are required Sanpress Inox labs free should be used. Labs free connectors are individually packaged and must be used immediately after opening the packaging. The press connectors are marked with a blue dot “Easytop slanted seated valves labs free” and “Easytop ball valves labs free” size 15 – 54 mm also belong to this system.

**Package size**

The articles are packed individually and can be recognised by the words: ›Labs-free‹



Fig. I – 45

Labs-free connectors are not to be used with substances, which are aggressive to car lacquer/paint, such as oils and greases!

**Labs-free press connector with SC Contur**

Recognisable by the blue dot



Fig. I – 46

### Easytop ball valves

Easytop ball valves are suitable for use in industrial installations for non-flammable gases. In pressurised air systems and all applications with non-flammable technical gases, the maximum operating pressure in the ambient temperature is 10 bar.

Profipress G ball valves are certified for flammable gases according to DVGW G260 to PN5 with HTB requirements GT/1.

#### Characteristics

- Maintenance, easily assembled
- Press technology for quick work and short down times
- Coloured caps for consequent media recognition



Fig. I – 47



Fig. I – 48

Media-  
marking

Shut-off for main-  
tenance unit



Fig. I – 49

Viega Systems and  
Ball Valves in an  
Industrial setting

Material suitability request		Material recommendations											
<b>Contact</b> Service Center – Technical Consulting Telephone +49 2722 61 1100 Fax +49 2722 61 1101 Email service-werkstoffanfrage@viega.de		Date: By:  (for Viega use only)											
Viega process-No.		Viega project-No.											
Date		Author											
Customer-No.													
①	Customer/Company	End consumer											
	Street	Contact person											
	Postcode/Town	Telephone											
	Telephone	Project size											
	Contact person	Running metre											
			Connectors										
Dimension: (mark the Viega-System in question with a cross)													
③	System/material	ProfiPress Copper	ProfiPress S Copper	Sanpress-Pipe 1.4401 Stainless steel	Sanpress-Pipe 1.4401 Stainless steel	Sanpress-Pipe 1.4521 Stainless steel	Sanpress-Pipe 1.4521 Stainless steel	ProfiPress G Copper	Sanpress Inox G Stainless steel	Prestabo Galvanized steel	Prestabo sendzimir Galvanized steel	Megapress Steel	
	Connector/ sealing	Copper / Gunmetal EPDM	Copper / Gunmetal FKM	Stainless steel EPDM	Gunmetal EPDM	Stainless steel EPDM	Gunmetal EPDM	Copper / Gunmetal HNBR	Stainless steel HNBR	verzinkter Stahl EPDM	Galvanized steel EPDM	Steel Zink-Nickel Beschichtung EPDM	
		<input type="checkbox"/>	<input type="checkbox"/>	<input type="checkbox"/>	<input type="checkbox"/>	<input type="checkbox"/>	<input type="checkbox"/>	<input type="checkbox"/>	<input type="checkbox"/>	<input type="checkbox"/>	<input type="checkbox"/>	<input type="checkbox"/>	
	④ Function of the whole system?												
	⑤ What function do the Viega components have in the system?												
	⑥ Which media will the material to be tested be exposed to? (Please enclose safety data sheets and specification sheets)												
	⑦ Are other substances expected in the medium? Example: Additives, cleaning materials, etc. When yes which substances and which concentration.												
	⑧ What quantity of the medium is to be transported? Please include relationship of the components when more than one.												
	⑨	Operating conditions											
		T <sub>max</sub>	Pressure surges		<input type="checkbox"/> yes	<input type="checkbox"/> no							
		T <sub>min</sub>	Stagnation		<input type="checkbox"/> yes	<input type="checkbox"/> no							
		p <sub>max</sub>	System		<input type="checkbox"/> open	<input type="checkbox"/> closed							
p <sub>min</sub>		Location of the unit		<input type="checkbox"/> outdoors	<input type="checkbox"/> indoors								
pH <sub>max</sub>													
pH <sub>min</sub>													
⑩ What is the planned lifespan of the system?													

Our recommendation are based on the information given reading use and operating conditions. The existing guarantee, especially the statutory guarantee, is not extended by this recommendation.

# 5Tool systems

## System descriptions

### Intended use

The functional safety of the Viega press connector system depends primarily on the flawless state of the press machine and pressing tools used. The detailed usage instructions enclosed when you purchase your pressing tools must be taken into consideration. When lending out or borrowing press machines, all the product information must be given to the user.

Press machines can be used at temperatures between -5 and +40°C - operating temperature assumed.

If the temperature is considerably less than 0°C, the hydraulic oil becomes viscous and the machines must be warmed up to room temperature before use. If this does not occur, the functionality will be affected and the mechanism may become damaged.

If a press machine is completely immersed in water, it must be sent for inspection to an authorised service station.

Irrespective of the legal regulations, Viega guarantees the impermeability of the connection as per the transferred liability agreement agreed with the ZVSHK and BHKS.

It extends the guarantee period required by the legislative authorities if Viega press machines and Viega pressing tools are used.

### Read and note the usage instructions!

### Use

-5 to +40°C

### Service stations

For maintenance and repair

### Transferred liability agreement

### Press machines

With mains and battery operation



Fig. W – 1

## Press machines

Safe, low-maintenance pressing tools are an important component of the Viega system. They are optimised for the materials and dimensions of the Viega press connectors, guaranteeing safety and function when used on the building site. Also because they can be used anywhere - with and without a mains connection.

We recommend using the following press machines

- Pressgun 5 with mains adapter
- Pressgun 5 with battery
- Pressgun 4 E
- Pressgun 4 B
- Pressgun Picco
- Picco
- PT3-EH
- PT3-AH
- PT2

### Pressgun 5 with mains adapter

#### Pressgun 5 with mains adapter

230 V – mains operation



Fig. W – 2

#### Features

- for all press connector sizes from 12 to 108.0 mm
- Optimal handling due to ergonomic pistol shape for one-handed operation
- Weight-reduced to 3.5 kg (without press jaws)
- 180° rotatable head
- Tripping delay, pin retainer, forced pressing and automatic return
- Lower maintenance and repair needs
- Service only needed after 42,000 pressings

## Pressgun 5 with battery

Battery press machine with the latest lithium ion technology



Fig. W – 3

The latest lithium ion battery technology enables smaller batteries with the same capacity, better performance with low temperatures and without the memory effect. Due to the rapid build-up of power, the pressing takes 3 to 4 seconds, depending on the size of the pipe.

### Features

- for all press connector sizes from 12 to 108.0 mm
- Ergonomic shape for optimal one-handed handling
- Weight-reduced to 3.2 kg (without press jaws)
- 180° rotatable head
- Tripping delay, pin retainer, forced pressing and automatic return
- Lower maintenance and repair needs
- Service only needed after 42,000 pressings

### Pressgun 5 in set with press jaws – Delivery overview

Pressgun 5	Model	Art.-No.	Use for press connector systems	Press jaw sizes [mm]
Mains supply	2293.1	707026	Metal	15 / 22 / 28
Battery	2293.2	707019		
Mains supply	5393.1	707040	Raxofix	16 / 20 / 25
Battery	5393.2	707033		
Mains supply	2295.1	707163	Without press jaws	
Battery	2295.2	707156		

Tab. W – 1

**Press machine 18 V / 2 Ah**

Lithium ion battery



Press machine  
18 V / 2 Ah

Lithium ion battery

### Pressgun Picco – Battery



Fig. W – 4

Pressgun Picco is the lightest and smallest of the Viega press machines. It is particularly handy and makes it possible to work in the smallest space and in narrow pre-wall constructions. It is predominantly used for installing Viega plastic pipe installation systems and for repair work in the customer service department.

Picco press jaws are designed to be weight-reduced, making them incompatible with the other Viega pressing tools.

#### Features

- For metallic press connectors, sizes 12 to 35 mm
- For plastic press connectors, sizes 12 to 40 mm
- Ergonomic shape for optimal one-handed handling
- Weight-reduced to 2.5 kg (without press jaws)
- 180° rotatable head
- Pin retainer
- Lower maintenance and repair needs
- Service only needed after 32,000 pressings



Fig. W-5



Fig. W-6



Fig. W-7

**Pressgun 5**

Lithium ion battery,  
mains supply and bat-  
tery charger

**Compatibility with Pressgun 4 battery and battery charger**

The batteries and battery chargers of the Pressgun 4 and the new Pressgun 5 are compatible.

**Compatibility with products from other manufacturers**

The prerequisite for certifications of the Viega pipe systems includes the successful inspection of the connecting technology in accordance with DVGW Worksheet W 534 by an authorised testing institute. To do this, the press connections are only made with Viega press machines and Viega pressing tools. If the technician uses press machines and tools from other manufacturers, it is recommended to obtain relevant proof of suitability in the sense of a liability immunity. If it can be proven in the case of a complaint that damage was caused by the use of pressing tools from other manufacturers, then Viega will reject any compensation claims.

**Proof of suitability  
for pressing tools**

## Pressing tools

### Jointed press rings

The patented Viega press rings and the jointed press jaws allow the press ring to rotate by up to 180°.

The joint makes it easier to press on hard-to-access components, pipe shafts and front-wall constructions.

### For Viega pipe systems made of metal

Press jaws and press rings are compatible with all Viega press machines.

#### Press ring set

Case set

12 to 35 mm  
with

hinged press jaws P1

Without fig.:  
42 to 54 mm  
with Z2



Fig. W – 8



Fig. W – 9

### For XL press connectors

For Viega press connectors Sanpress Inox XL, Prestabo XL and Profipress XL (press connectors made of copper) in XL dimensions: 64.0 / 76.1 / 88.9 and 108.0 mm.

#### Press rings

64.0 to 108.0 mm

with

Hinged press jaws Z 2,  
also available as a set  
in a case



Fig. W – 10

**Press chains / press jaws**

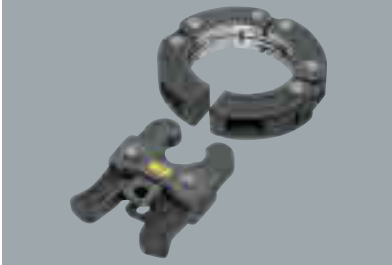

Fig. W – 11

Press chains with hinged press jaws  
 For Pressgun 5  
 XL dimensions: 76.1 to 108.0 mm  
 For Sanpress XL press connector  
 made of gunmetal

**XL dimensions**



Fig. W – 12

For Raxofix press connector system.  
 Suitable for all Viega press machines except Picco, Pressgun Picco.

- Sizes 12 to 63 mm for plastic pipe systems
- Sizes 12 to 54 mm for metallic press connector systems



Fig. W – 13

For Picco and Pressgun Picco

- Sizes 12 to 40 mm for plastic pipe systems
- Sizes 12 to 35 mm for metallic press connector systems

**Metal and plastic pipe systems**



Fig. W – 14

For Raxofix press connector system.  
 Suitable for all Viega press machines except Picco, Pressgun Picco.  
 Sizes: 16 to 63 mm













Fig. W – 15





For Raxofix press connector system.  
 For press machines Picco, Pressgun Picco  
 Sizes: 16 to 40 mm

**Raxofix press connector system**



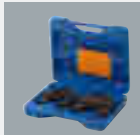

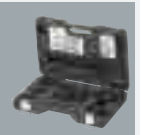

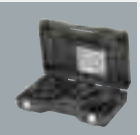

## Compatibility

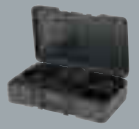
Pressing tool sets Press jaws Press rings Press chains					
<b>Product description</b>	<b>SOM</b>	<b>SOM</b>	<b>PT2</b>	<b>SOM</b>	<b>SOM</b>
Model / Article number	2299.6/313012	2299.62/449377	2299.9	2299.2	2299.4/262211
Dimension {mm}	12–35	15–28	12–35	12–54, 14/16	42–54
Bolt – Diameter {mm}	15	15	14	15	15
 <b>Pressgun 5</b> Press gun mains	✓	✓	✓	✓	✓
 <b>Pressgun 5</b> Press gun with battery	✓	✓	✓	✓	✓
 <b>Pressgun Picco</b>	–	–	–	–	–
 <b>Pressgun 4E</b>	✓	✓	✓	✓	✓
 <b>Pressgun 4B</b>	✓	✓	✓	✓	✓
<b>Systems</b>	Profipress/G Seapress Prestabo Sanpress Inox/G Sanpress				





1/3

						
<b>SOM/M</b>	<b>Picco</b>		<b>Z1</b>	<b>Z2</b>	<b>PT2</b>	
2299.4M/315337 42–54 15	2484.9 12–35 12	2296.3/472757 12–35 14 No longer available	2296.2/472733 12–35/16–25 14	2296.2/472740 42–108.0/32–63 14	2497.3XL/562854 76.1–108.0 14	2497.2XL 64.0–108.0 –
Only size 42	–	✓	✓	✓	✓	✓
Only size 42	–	✓	✓	✓	✓	✓
–	✓	–	–	–	–	–
Only size 42	–	✓	✓	✓	✓	✓
Only size 42	–	✓	✓	✓	✓	✓
Profipress/G Seapress Prestabo Sanpress Inox/G Sanpress					Prestabo XL Sanpress Inox/XL Sanpress Inox G/XL Profipress XL <small>(only press connectors made of copper)</small> Seapress XL	

## Compatibility



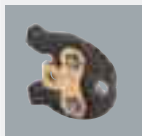

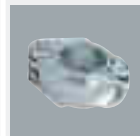





Pressing tool sets Press jaws Press rings Press chains					
Product description			<b>PT2</b>		<b>SOM</b>
Model / Article number	2296.1	2297.3XL/362959	2297.2XL	2297.1XL/359232	2299.81/490652
Dimension {mm}	12–54	76.1–108.0	76.1–108.0	76.1–108.0	16–32
Bolt – Diameter {mm}	–	14	–	14	15
 Pressgun 5 Press gun mains	✓	✓	✓	✓	✓
 Pressgun 5 Press gun with battery	✓	✓	✓	✓	✓
 Pressgun Picco	Only sizes ≤35mm	–	–	–	–
 Pressgun 4E	✓	✓	✓	✓	✓
 Pressgun 4B	✓	✓	✓	✓	✓
Systems	Profipress/G Seapress Prestabo Sanpress Inox/G Sanpress	Profipress XL Sanpress XL			Sanfix Fosta/Plus

2/3

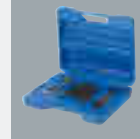



						
<b>SOM</b> 2299.8/357139 16, 20 15	<b>PT2</b> 2299.41/612191 50, 63 14	<b>PT2/SOM</b> 2299.7 14–63 14/15	<b>Picco</b> 2484.7 12–40 12	<b>PT2</b> 9696.6/469764 20–25 14	<b>PT2</b> 9696.7/469771 32–63 14	9696.1 20–63 –
✓	✓	✓	–	✓	✓	✓
✓	✓	✓	–	✓	✓	✓
–	–	–	✓	–	–	–
✓	✓	✓	–	✓	✓	✓
✓	✓	✓	–	✓	✓	✓
<b>Sanfix Fosta/Plus</b>	<b>Sanfix Fosta</b>	<b>Sanfix Fosta/Plus Fonterra</b>		<b>Geopress</b>		

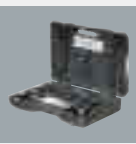

## Compatibility

Pressing tool sets Press jaws Press rings Press chains					
Product description Model / Article number Dimension {mm} Bolt – Diameter {mm}	<b>Pressringset+P1</b> 2496.3/622664 12–35 12	2296.4/472764 42–54 14	<b>P1</b> 2496.1/622657 12–35 12	<b>PT2</b> 2799.7/425302 12 14	<b>Combi-press jaw</b> 2298.3 15 No longer available!
 <b>Pressgun 5</b> Press gun mains	—	✓	—	✓	✓
 <b>Pressgun 5</b> Press gun with battery	—	✓	—	✓	✓
 <b>Pressgun Picco</b>	✓	—	✓	—	—
 <b>Pressgun 4E</b>	—	✓	—	✓	✓
 <b>Pressgun 4B</b>	—	✓	—	✓	✓
<b>Systems</b>	Profipress/G Seapress Prestabo Sanpress Inox/G Sanpress			<b>Fonterra</b>	Profipress/G Seapress Prestabo Sanpress Inox/G Sanpress 12–22mm Sanfix Fosta/Plus 14–20mm

3/3

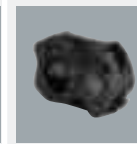
				
<b>PT2</b> 5399.8/645380 16–20 14	<b>PT2</b> 5399.81/645397 16–32 14	<b>PT2</b> 5399.7 16–63 14	<b>Picco</b> 5384.7 16–40 12	5396.1 16–63 –
✓	✓	✓	–	✓
✓	✓	✓	–	✓
–	–	–	✓	Only sizes ≤35mm
✓	✓	✓	–	✓
✓	✓	✓	–	✓
<b>Raxofix</b>				

## Maintenance

### Care und cleaning

#### Pressing tools

Store the press jaws socket with the press rollers in a dry and clean place. After every use, clean the pressing tools with a cloth. When necessary, oil any moveable parts, such as bolts and press rollers. Regularly furbish and oil inserts and contours of the press jaws with fine steel wool or cleaning fle-  
e-  
ece.

#### Press machines

The functional safety of the press machines and the long-term sealing of the press connection depend on the condition of the pressing tools in the first instance. Viega press machines are electro-hydraulic devices, which achieve a pre-set pressure during the pressing procedure. Only a solid hydraulic system guarantees operational safety and reliability.

Like all electro-hydraulic tools, Viega press machines are subject to a natural wear-and-tear. For this reason, they must be regularly maintained or left with Viega-appointed service points for inspection.

#### Maintenance intervals for Viega press machines

Type	Maintenance interval
<b>Pressgun 5</b>	After 40,000 pressings, a service notification can be seen on the LED display. After another 2,000 pressings, a safety shutdown occurs. Maintenance after no more than 4 years.
<b>Pressgun Picco</b>	After 30,000 pressings, a service notification can be seen on the LED display. After another 2,000 pressings, a safety shutdown occurs. Maintenance after no more than 4 years.
<b>Pressgun 4 E</b>	
<b>Pressgun 4 B</b>	
<b>Type PT3-AH</b>	After 20,000 pressings, a service notification can be seen on the LED display. After another 2,000 pressings, a safety shutdown occurs. Maintenance after no more than 4 years.
<b>Picco</b>	
<b>Type PT3-H/EH</b>	
<b>Type 2</b>	Every 2 years.
<b>Model 2478</b>	At least annually.
<b>Model 2475</b>	After 20,000 pressings, a message is displayed on the LED. Maintenance after no more than 4 years.

Tab. W – 2

### Press rings / press jaws

To maintain functionality, we recommend having press rings and press jaws maintained regularly with the press machines. During the maintenance procedure, consumables are replaced, press jaw contours are revised and the press jaws are reset.

Since January 2012, we have started to provide Viega press jaws with maintenance stickers.



Fig. W – 16

#### Service reminder

Reminder of inspection in the third quarter of 2014

### Tool Service

#### Repairs and maintenance

<b>Austria</b>	König & Landl	2020 Hollabrunn
<b>Belgium</b>	Indu Tools	1850 Grimbergen
	Ridge Tool Europe	3001 Heverlee
<b>Czech Republic</b>	Mátl & Bulla	66461 Brno
<b>Denmark</b>	Scherer's	2610 Rodovre
<b>Finland</b>	Alpillan	810 Helsinki
<b>France</b>	Fa. Striebel	67602 Selestat
	MEP Hire	ML43NH Glasgow
<b>Great Britain</b>	Broughten Plant Hire and Sales	RN3 8UJ Romford, Essex
	Ergon Equipment	15344 Athen
<b>Italy</b>	Elmes	39040 Neumarkt
	O.R.E	47900 Rimini
<b>Netherlands</b>	MG Service	5388 RT Nistelrode
<b>Norway</b>	Grønvold Maskinservice	0613 Oslo
<b>Spain</b>	Tecno Izqueierdo	28026 Madrid
<b>Sweden</b>	AB Lindströms	39241 Kalmar
<b>Switzerland</b>	Von Arx	4450 Sissach

Tab. W – 3

